

EU



E-Tech



Franklin Electric

VERTICAL MULTISTAGE PUMPS

EV 1 - 3 - 6 - 10 - 15 - 20 - 30 - 45 - 65 - 95

50Hz



INDEX

EV Series Vertical Multistage Pumps Overview	2
General Product Curves	3
Table of hydraulic performances at 50Hz - EV 1 - 3	4
Material Table	5
Table of hydraulic performances at 50Hz - EV 6 - 10	6
Material Table	7
Table of hydraulic performances at 50Hz - EV 15 - 20	8
Material Table	9
Table of hydraulic performances at 50Hz - EV 30 - 45	10
Material Table	11
Table of hydraulic performances at 50Hz - EV 65 - 95	12
Material Table	13
Motors - AEG	14
Mechanical seal specifications	16
<hr/>	
Performance Curves and Technical Data 50Hz	
EV 1 MEI \geq 0,70	19
EV 3 MEI \geq 0,70	25
EV 6 MEI \geq 0,70	31
EV 10 MEI \geq 0,70	37
EV 15 MEI \geq 0,70	43
EV 20 MEI \geq 0,70	47
EV 30 MEI \geq 0,70	51
EV 45 MEI \geq 0,70	55
EV 65 MEI \geq 0,70	59
EV 95 MEI \geq 0,70	63
<hr/>	
Pump Section and List of Main Components	67
<hr/>	
Dimensions of counterflanges	74
<hr/>	

EV Series 1 - 3 - 6 - 10 - 15 - 20 - 30 - 45 - 65 - 95

Vertical Multistage Centrifugal Pumps

APPLICATIONS

- Boiler feed
- Circulation of hot and cold water for heating, cooling and conditioning systems
- Handling of water, free of suspended solids, in the civil, industrial and agricultural sector
- Irrigation systems
- Pressure boosting and water supply systems
- Wash down unit
- Water treatment plants

FEATURES

- Full stainless steel in contact with water (inox version), compact and solid structure
- Diffuser bushing made of graphite for durability against dry running (EV 30-45-65-95)
- Easy disassembly without any special tool
- Easy installation in-line ports
- Fabricated stainless steel impeller and diffuser for corrosion resistance and superior efficiency
- New hydraulic design for the highest efficiency
- Oversize ball bearing (bearing bracket) ensures motor-bearing long life and eliminates axial and other adjustments of moving parts
- WRAS certified PPS (EV 1-3-6-10) / PTFE (EV 15-20-30-45-65-95) replacement floating neck ring for cost effective maintenance and long-lasting performance
- Removal of the mechanical seal without dismounting the pump; for models higher than 4 kW no need to dismantle the motor
- Replaceable stainless steel wear ring in the neck of the impeller (EV 30-45-65-95)
- Shaft bearing and journal sleeve made of tungsten carbide
- Standard mechanical seal (EN 12756 ex DIN 24960) WRAS certified; balanced version for EV 30-45-65-95
- Standard IE3 motor without oversize bearing, size B14 up to 4kW / size B5 from 5.5kW and above
- Tungsten carbide intermediate bearing to control and eliminate vibration and stabilize the rotor with a large number of stages

SPECIFICATIONS

- Capacities up to 120 m³/h at 50Hz
- Head up to 320 m at 50Hz
- Direction of rotation: clockwise looking at the pump from the top down
- Discharge and Suction port: Oval, Round flanges, Victaulic and Clamp connections
- Hydraulic characteristics are guaranteed, according to ISO standard 9906:2012, grade 3B
- Liquid temperature range: from -15°C to +120°C
- Materials: suitable for handling potable water (materials approved WRAS, ACS, KTW)
- Maximum working pressure: Oval flange 16 Bar; Round Flange, Victaulic and Clamp connections 25 Bar
- Motor powers from 0,37 to 45 kW at 50Hz

AVAILABLE ON REQUEST

- AISI 304 version for models 30-45-65-95
- Special materials for the mechanical seal, gaskets and elastomers
- Balanced mechanical seal EN 12756 for EV 1-3-6-10-15-20
- Oval counter flanges (EV 1-3-6-10-15-20)
- Round counter flanges

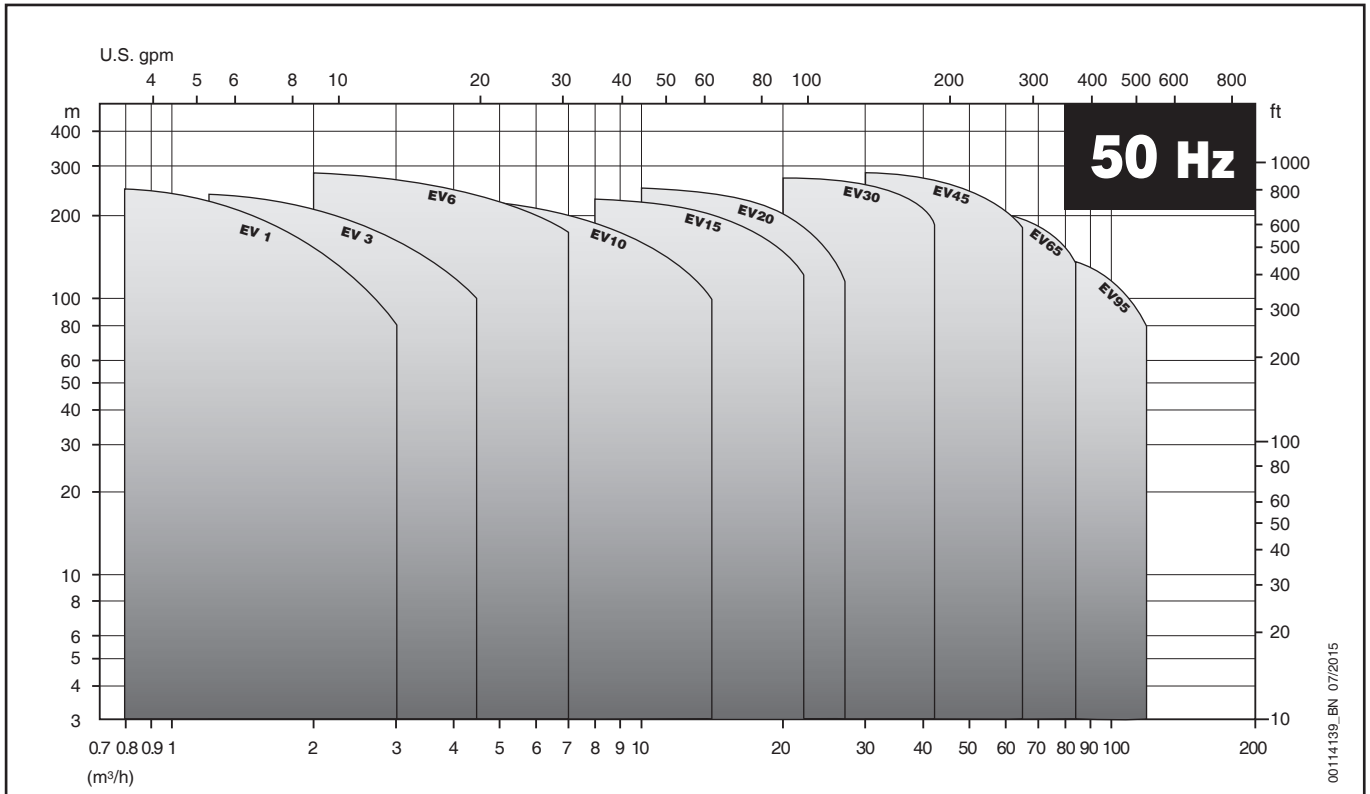

00114199_BN_07/2015

ex.

PUMP IDENTIFICATION CODE

EV 30 / 15 -1A F G 015 T B E1 IE3

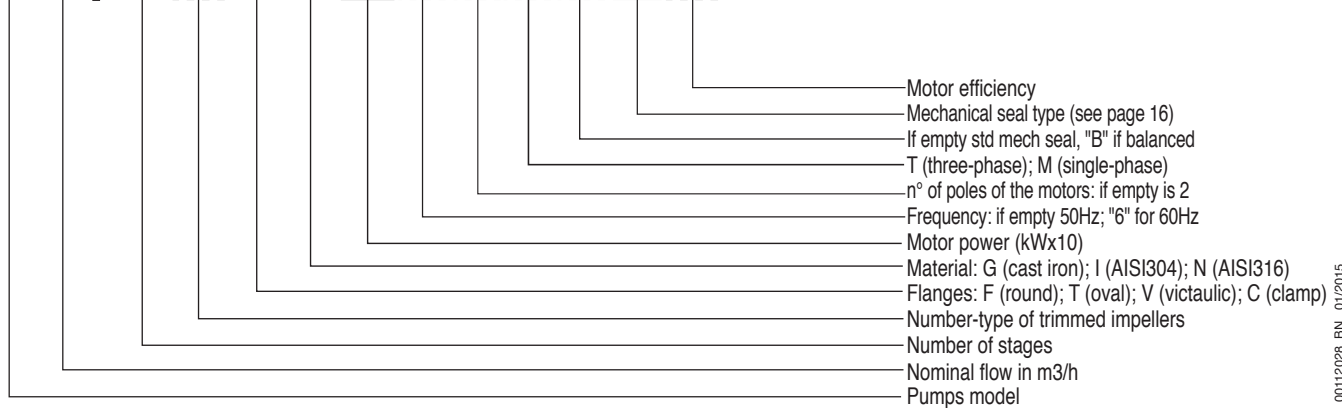

00112028_BN_01/2015

Versions	Pump body/Hydraulics	EV 1	EV 3	EV 6	EV 10	EV 15	EV 20	EV 30	EV 45	EV 65	EV 95
I	AISI 304 / AISI 304	●	●	●	●			○	○	○	○
G	CAST IRON / AISI 304							●	●	●	●
N	AISI 316 / AISI 316	●	●	●	●	●	●	●	●	●	●

● = Std version

○ = Available on request

Models	Maximum working pressure										
	EV 1	EV 3	EV 6	EV 10	EV 15	EV 20	EV 30	EV 45	EV 65	EV 95	
	bar	bar	bar	bar	bar	bar	bar	bar	bar	bar	
T version	16	16	16	16	16	16					
F, V and C version	26	26	26	26	26	26					
F version (PN16)							16	16	16	16	
F version (PN25/40)							32	32	25	25	
Maximum inlet pressure (H1)	refer to the tables of hydraulic performances										

The Inlet pressure of the pump plus the pressure inside the pump cannot exceed the maximum working pressure.

EV 1-3

TABLE OF HYDRAULIC PERFORMANCES AT 50Hz

PUMP TYPE	RATED POWER		H1 Bar	Q = DELIVERY																		
	kW	HP		l/min	8,3	16,7	25,0	33,3	42	50,0	58,3	67	75,0	83,3	90	100,0	116,7	133	150,0	166,7	183	233,3
				m ³ /h	0,5	1	1,5	2	2,5	3	3,5	4	4,5	5	5,4	6	7	8	9	10	11	14
H = TOTAL HEAD METERS COLUMN OF WATER																						
EV 1/2	0,37	0,5	20	14,5	13,5	12,5	11,5	9,5	7,5													
EV 1/3	0,37	0,5	20	21,5	20	19	17	14	11													
EV 1/4	0,37	0,5	20	28	26,5	24,5	22	18,5	14													
EV 1/5	0,37	0,5	20	35	33	30,5	27	22,5	17													
EV 1/6	0,37	0,5	20	41,5	39	36	32	26,5	19,5													
EV 1/7	0,37	0,5	20	48	45	41,5	36,5	30	22													
EV 1/8	0,55	0,75	20	55	52	48	42,5	35	26													
EV 1/9	0,55	0,75	20	61,5	58	53	47	39	28,5													
EV 1/10	0,55	0,75	20	68	64	58,5	51,5	43	31,5													
EV 1/11	0,55	0,75	20	74,5	69,5	64	56,5	46,5	34													
EV 1/12	0,75	1	20	83	78,5	72	64	53	39,5													
EV 1/13	0,75	1	20	89,5	84,5	77,5	68,5	57	42													
EV 1/14	0,75	1	20	96	90,5	83	73	60,5	44,5													
EV 1/15	0,75	1	20	102,5	96	88	78	64	47													
EV 1/17	1,1	1,5	20	118	111,5	103	91,5	76	56,5													
EV 1/19	1,1	1,5	20	131	123,5	114	101	84	62													
EV 1/22	1,1	1,5	20	150,5	141,5	130	115	95	69,5													
EV 1/23	1,5	2	20	160,5	152	140	124,5	104	77,5													
EV 1/25	1,5	2	20	174	164	151,5	134,5	112	83,5													
EV 1/27	1,5	2	20	187	176,5	162,5	144	120	88,5													
EV 1/30	1,5	2	20	206,5	194,5	179	158	131	96,5													
EV 1/32	2,2	3	20	224,5	213	197	175,5	147,5	110,5													
EV 1/34	2,2	3	20	238	225,5	208,5	185,5	155,5	116,5													
EV 1/37	2,2	3	20	258	244	225,5	200,5	167,5	125													
EV 3/2	0,37	0,5	20	15		15	14,5	13,5	12,5	11,5	10	8	6									
EV 3/3	0,37	0,5	20	22,5		22	21	20	18,5	17	14,5	12	8,5									
EV 3/4	0,37	0,5	20	30		28,5	27,5	26	24	21,5	18,5	15	10,5									
EV 3/5	0,55	0,75	20	37,5		36	34,5	32,5	30	27	23,5	18,5	13									
EV 3/6	0,55	0,75	20	44,5		42,5	40,5	38,5	35,5	32	27	21,5	15									
EV 3/7	0,75	1	20	52,5		50,5	48,5	46	43	38,5	33	26,5	19									
EV 3/8	0,75	1	20	59,5		57,5	55	52	48	43,5	37	29,5	21									
EV 3/9	0,75	1	20	67		64	61,5	58	53,5	48	41	32,5	22,5									
EV 3/10	1,1	1,5	20	75		72,5	70	66,5	61,5	55,5	48	38,5	27,5									
EV 3/11	1,1	1,5	20	82,5		79,5	76,5	72,5	67	60,5	52	42	29,5									
EV 3/12	1,1	1,5	20	89,5		86	83	78,5	72,5	65	56	45	31,5									
EV 3/13	1,1	1,5	20	96,5		93	89	84,5	78	70	60	47,5	33,5									
EV 3/14	1,5	2	20	105,5		102	98,5	93,5	86,5	78	67,5	54,5	39,5									
EV 3/15	1,5	2	20	112,5		109	105	99,5	92,5	83	71,5	58	41,5									
EV 3/16	1,5	2	20	120		115,5	111,5	105,5	98	88	76	61	43,5									
EV 3/17	1,5	2	20	127		122,5	118	111,5	103,5	93	80	64	45,5									
EV 3/18	2,2	3	20	136,5		132,5	128	121,5	113,5	102,5	89	72,5	53									
EV 3/19	2,2	3	20	144		139,5	134,5	128	119	107,5	93,5	76	55,5									
EV 3/21	2,2	3	20	158,5		153,5	148	140,5	130,5	118	102	83	60									
EV 3/23	2,2	3	20	173		167,5	161,5	153	142	128	110,5	89,5	64,5									
EV 3/25	2,2	3	20	187,5		181	174,5	165,5	153,5	138	119	96	68,5									
EV 3/27	3	4	20	205,5		199,5	193	184	171,5	155	135	110,5	81									
EV 3/29	3	4	20	220		213,5	206,5	196,5	183,5	166	144	117,5	86									
EV 3/31	3	4	20	235		228	220,5	209,5	195	176,5	153	124,5	91									
EV 3/33	3	4	20	249,5		242	234	222	206,5	187	162	131,5	95,5									

EV 1-3

MATERIAL IN CONTACT WITH THE LIQUID						
Pos.	PARTS DESCRIPTIONS	Type	MATERIAL			
			I version		N version	
			ASTM/AISI	DIN / EN	ASTM/AISI	DIN / EN
10.00	Pump casing	Stainless Steel	CF 8 / AISI 304	1.4308	CF 8M / AISI 316	1.4408
10.02	Filling and draining plug	Stainless Steel	AISI 304	1.4301	AISI 316	1.4401
10.06	Upper flange	Stainless Steel	AISI 304	1.4301	AISI 316	1.4401
20.00	Outer Case	Stainless Steel	AISI 304	1.4301	AISI 316	1.4401
20.01	Mechanical seal housing	Stainless Steel	AISI 304	1.4301	AISI 316	1.4401
20.05	Filling plugs	Stainless Steel	AISI 304	1.4301	AISI 316	1.4401
30.00	Pump shaft	Stainless Steel	AISI 304	1.4301	AISI 316	1.4401
30.01	Kit Mechanical seal	Silicon Carbide SiC, Graphite, EPDM, Stainless Steel	-	-	-	-
30.02	Mechanical seal fastening kit	Stainless Steel	AISI 304	1.4301	AISI 316	1.4401
30.03	Kit O-rings	EPDM	-	-	-	-
40.00	Stage housing and diffuser	Stainless Steel	AISI 304	1.4301	AISI 316	1.4401
40.01	Stage Centering outlet	Stainless Steel	AISI 304	1.4301	AISI 316	1.4401
40.02	Floating neck ring	PPS	-	-	-	-
40.03	Initial stage housing	Stainless Steel	AISI 304	1.4301	AISI 316	1.4401
40.04	Last Stage with diffuser	Stainless Steel	AISI 304	1.4301	AISI 316	1.4401
40.05	Stage Centering inlet	Stainless Steel	AISI 304	1.4301	AISI 316	1.4401
40.06	Stage housing and diffuser with bearing	Stainless Steel / Tungsten Carbide	AISI 304	1.4301	AISI 316	1.4401
50.00	Impeller	Stainless Steel	AISI 304	1.4301	AISI 316	1.4401
50.01	Impeller spacer	Stainless Steel	AISI 304	1.4301	AISI 316	1.4401
50.02	Intermediary sleeve	Tungsten Carbide	-	-	-	-
50.03	Intermediary sleeve spacer	Stainless Steel	AISI 304	1.4301	AISI 316	1.4401

EV 6-10

TABLE OF HYDRAULIC PERFORMANCES AT 50Hz

PUMP TYPE	RATED POWER		H1 Bar	Q = DELIVERY																		
	kW	HP		l/min	8,3	16,7	25,0	33,3	42	50,0	58,3	67	75,0	83,3	90	100,0	116,7	133	150,0	166,7	183	233,3
				m ³ /h	0,5	1	1,5	2	2,5	3	3,5	4	4,5	5	5,4	6	7	8	9	10	11	14
H = TOTAL HEAD METERS COLUMN OF WATER																						
EV 6/2	0,37	0,5	20	15		15	14,5	14,5	14	13,5	13	12,5	12	11,5	11	10	8					
EV 6/3	0,37	0,5	20	22,5		22	21,5	21	20,5	19,5	19	18	17	16	15,5	14	11					
EV 6/4	0,55	0,75	20	29,5		29	28,5	28	27	26	25	24	22,5	21,5	20,5	18,5	14,5					
EV 6/5	0,75	1	20	37,5		37	36,5	35,5	34,5	33,5	32	30,5	29	27,5	26	24	19					
EV 6/6	0,75	1	20	44,5		43,5	43	42	41	39,5	37,5	36	34	32,5	30,5	28	22					
EV 6/7	1,1	1,5	20	52,5		51,5	51,5	50,5	49	47	45	43	41	39	37	34	27					
EV 6/8	1,1	1,5	20	59,5		58,5	58	57	55	53,5	51	48,5	46,5	44	42	38,5	30,5					
EV 6/9	1,1	1,5	20	67		65,5	65	63,5	61,5	59	56,5	54	51,5	48,5	46	42,5	33,5					
EV 6/10	1,5	2	20	75		74	73,5	72	70	67,5	65	62	59	56	53,5	49	39					
EV 6/11	1,5	2	20	82,5		81	80,5	79	76,5	73,5	71	67,5	64,5	61	58	53,5	42,5					
EV 6/12	1,5	2	20	89,5		88	87	85,5	83	80	76,5	73	69,5	65,5	62,5	57,5	45,5					
EV 6/13	1,5	2	20	97		95	94	92	89	86	82	78,5	74,5	70,5	67	61,5	48,5					
EV 6/14	2,2	3	20	105,5		104,5	103,5	101,5	99	95,5	92	88	83,5	79,5	76	70	56					
EV 6/15	2,2	3	20	113		111,5	110,5	108,5	105,5	102	98	93,5	89	84,5	80,5	74	59,5					
EV 6/16	2,2	3	20	120,5		118,5	117,5	115,5	112	108	104	99	94,5	89,5	85,5	78,5	62,5					
EV 6/17	2,2	3	20	127,5		125,5	124,5	122	118,5	114,5	109,5	105	99,5	94,5	90	83	66					
EV 6/18	2,2	3	20	135		132,5	131,5	128,5	125	120,5	115,5	110,5	105	99,5	94,5	87	69					
EV 6/19	2,2	3	20	142		139,5	138	135,5	131,5	126,5	121,5	115,5	110	104	99	91	72					
EV 6/20	3	4	20	152		150	149	146,5	142,5	138	133	127	121	115	110	101,5	82					
EV 6/21	3	4	20	159		157,5	156	153,5	149,5	144,5	139	133	127	120,5	115	106	85,5					
EV 6/23	3	4	20	174		172	170,5	167,5	163	157,5	151,5	144,5	138	131	125	115	92,5					
EV 6/25	3	4	20	189		188	184,5	180,5	175,5	170	164	157,5	150,5	142,5	135,5	123,5	98,5					
EV 6/28	4	5,5	20	214		213,5	210	205,5	200,5	194,5	188	181	173,5	164,5	156,5	143	115,5					
EV 6/30	4	5,5	20	229		228	224,5	220	214	207,5	200,5	193	184,5	175,5	167	152,5	122,5					
EV 6/33	4	5,5	20	251,5		250,5	246,5	241	234,5	227	219,5	211	201,5	191	182	166	133,5					
EV 6/36	5,5	7,5	20	275		274	270	264	257,5	249,5	241,5	232,5	222,5	211,5	201,5	184	148,5					
EV 10/2	0,75	1	20	20						20	19,5	19,5	19	19	18,5	18,5	17,5	17	16	15	13,5	9
EV 10/3	1,1	1,5	20	30						30	29,5	29,5	29	28,5	28	27,5	26,5	25,5	24	22,5	20,5	13,5
EV 10/4	1,5	2	20	40,5						40	39,5	39,5	39	38,5	38	37	35,5	34	32,5	30,5	28	18
EV 10/5	1,5	2	20	50,5						49,5	49	48,5	48	47	46,5	45,5	43,5	41,5	39,5	37	33,5	21,5
EV 10/6	2,2	3	20	61						60,5	60	59	58,5	57,5	57	56	54	51,5	49	46	42	27,5
EV 10/7	2,2	3	20	70,5						70	69	68,5	67,5	66,5	66	64,5	62	59,5	56	52,5	48	31
EV 10/8	3	4	20	81,5						81	80,5	80	79	78	77	75,5	73	70	66,5	62,5	57,5	38
EV 10/9	3	4	20	91,5						91	90,5	89,5	88,5	87,5	86	84,5	81,5	78	74	69,5	64	42
EV 10/10	4	5,5	20	102,5						102,5	102	101	100	99	97,5	96	93	89	84,5	79,5	73,5	49
EV 10/11	4	5,5	20	113						112,5	111,5	111	109,5	108	107	105	101,5	97,5	92,5	87	80,5	53,5
EV 10/12	4	5,5	20	123						122,5	121,5	120,5	119	117,5	116,5	114	110	105,5	100,5	94	87	57,5
EV 10/13	4	5,5	20	133						132	131	130	128,5	127	125,5	123	118,5	113,5	108	101	93,5	61,5
EV 10/15	5,5	7,5	20	153,5						153	152	150,5	149	147	145,5	142,5	138	132	125,5	118	109	72
EV 10/17	5,5	7,5	20	173,5						172,5	171,5	169,5	168	165,5	163,5	160,5	155	148,5	141	132,5	122	80,5
EV 10/19	7,5	10	20	195						194,5	193,5	191,5	189,5	187,5	185,5	182	176	169	160,5	151	139,5	93
EV 10/21	7,5	10	20	215,5						214,5	213	211	209	206	204	200	193,5	185,5	176,5	166	153	101,5
EV 10/23	7,5	10	20	235,5						234	232,5	230,5	228	225	222,5	218,5	211	202	192	180,5	166,5	110
EV 10/24	11	15	20	248						248,5	247	245,5	243	240,5	238	234	227	218	208	196	182	122,5

EV 6-10

MATERIAL IN CONTACT WITH THE LIQUID						
Pos.	PARTS DESCRIPTIONS	Type	MATERIAL			
			I version		N version	
			ASTM/AISI	DIN / EN	ASTM/AISI	DIN / EN
10.00	Pump casing	Stainless Steel	CF 8 / AISI 304	1.4308	CF 8M / AISI 316	1.4408
10.02	Filling and draining plug	Stainless Steel	AISI 304	1.4301	AISI 316	1.4401
10.06	Upper flange	Stainless Steel	AISI 304	1.4301	AISI 316	1.4401
20.00	Outer Case	Stainless Steel	AISI 304	1.4301	AISI 316	1.4401
20.01	Mechanical seal housing	Stainless Steel	AISI 304	1.4301	AISI 316	1.4401
20.05	Filling plugs	Stainless Steel	AISI 304	1.4301	AISI 316	1.4401
30.00	Pump shaft	Stainless Steel	AISI 304	1.4301	AISI 316	1.4401
30.01	Kit Mechanical seal	Silicon Carbide SiC, Graphite, EPDM, Stainless Steel	-	-	-	-
30.02	Mechanical seal fastening kit	Stainless Steel	AISI 304	1.4301	AISI 316	1.4401
30.03	Kit O-rings	EPDM	-	-	-	-
40.00	Stage housing and diffuser	Stainless Steel	AISI 304	1.4301	AISI 316	1.4401
40.01	Stage Centering outlet	Stainless Steel	AISI 304	1.4301	AISI 316	1.4401
40.02	Floating neck ring	PPS	-	-	-	-
40.03	Initial stage housing	Stainless Steel	AISI 304	1.4301	AISI 316	1.4401
40.04	Last Stage with diffuser	Stainless Steel	AISI 304	1.4301	AISI 316	1.4401
40.05	Stage Centering inlet	Stainless Steel	AISI 304	1.4301	AISI 316	1.4401
40.06	Stage housing and diffuser with bearing	Stainless Steel / Tungsten Carbide	AISI 304	1.4301	AISI 316	1.4401
50.00	Impeller	Stainless Steel	AISI 304	1.4301	AISI 316	1.4401
50.01	Impeller spacer	Stainless Steel	AISI 304	1.4301	AISI 316	1.4401
50.02	Intermediary sleeve	Tungsten Carbide	-	-	-	-
50.03	Intermediary sleeve spacer	Stainless Steel	AISI 304	1.4301	AISI 316	1.4401

EV 15-20

TABLE OF HYDRAULIC PERFORMANCES AT 50Hz

PUMP TYPE	RATED POWER		H1 Bar	Q = DELIVERY																										
	kW	HP		l/min	25	33	42	50	58	67	75	83	90	100	117	133	167	200	233	266	300	333	367	400	433,5	466,5				
				m ³ /h	1.5	2	2.5	3	3.5	4	4.5	5	5.4	6	7	8	10	12	14	16	18	20	22	24	26	28				
H = TOTAL HEAD METERS COLUMN OF WATER																														
EV 15/1	1,1	1,5	20	14,5												13	12,5	12	11,5	10,5	9,5	8,5	7	5,5						
EV 15/2	2,2	3	20	29												26	25	24	23	21,5	19,5	17	14	11						
EV 15/3	3	4	20	43,5												39	38	36,5	34,5	32,5	29,5	26	21,5	17						
EV 15/4	4	5,5	20	58												52,5	51	49	46,5	44	40,5	35,5	29,5	23,5						
EV 15/5	4	5,5	20	72,5												65,5	63,5	60,5	57,5	54,5	49,5	43	36	28,5						
EV 15/6	5,5	7,5	20	87,5												79,5	77	74	71	67	61,5	54	46	36,5						
EV 15/7	5,5	7,5	20	102												92	89	86	82	77,5	70,5	62	52,5	41,5						
EV 15/8	7,5	10	20	117												106,5	103	99,5	95	90	82,5	72,5	62	49						
EV 15/9	7,5	10	20	131,5												119	115,5	111	106	100,5	92	81	69	54,5						
EV 15/10	11	15	20	147,5												134,5	131	126,5	121	115	106	94	80,5	65						
EV 15/11	11	15	20	162												148	143,5	139	133	126,5	116,5	103	88,5	71						
EV 15/12	11	15	20	176,5												161	156,5	151	144,5	137,5	126,5	112	96	77						
EV 15/13	11	15	20	191												174,5	169	163,5	156,5	148,5	136,5	120,5	103	82,5						
EV 15/14	11	15	20	205,5												187,5	182	175,5	168	159	146	129	110,5	88						
EV 15/15	15	20	20	221												201	195,5	188,5	180,5	171,5	157,5	139,5	119,5	95,5						
EV 15/16	15	20	20	235,5												214	208	200,5	192	182,5	167,5	148	126,5	101,5						
EV 15/17	15	20	20	249,5												227,5	220,5	213	203,5	193	177,5	156,5	134	107						
EV 20/1	1,1	1,5	20	15,5												13,5	13	13	12,5	12	11	10	8,5	7,5	6					
EV 20/2	2,2	3	20	31												27,5	27	26	25	24	22,5	20,5	18	15	12					
EV 20/3	4	5,5	20	46,5												41,5	40,5	39,5	38	36,5	34,5	31	27,5	23	18,5					
EV 20/4	5,5	7,5	20	62,5												56	55	53,5	51,5	49,5	46,5	42,5	37	31,5	25,5					
EV 20/5	5,5	7,5	20	78												70	68,5	66,5	64,5	62	58	53	47	40	32,5					
EV 20/6	7,5	10	20	94,5												86,5	84,5	82,5	80	77,5	73,5	67,5	60	52	42,5					
EV 20/7	7,5	10	20	110												100,5	98	95,5	93	90	85	77,5	69	59,5	48,5					
EV 20/8	11	15	20	126,5												117	114	112	109	106	100,5	92,5	82,5	72	59,5					
EV 20/9	11	15	20	142,5												131	128	125,5	122	118,5	112,5	103,5	92,5	80,5	66,5					
EV 20/10	11	15	20	158												145,5	142	139	135	131,5	124,5	114	102	88,5	73					
EV 20/11	15	20	20	174												160	156,5	153	149	144,5	137	126	113	98	81					
EV 20/12	15	20	20	189,5												174,5	170,5	167	162	157,5	149	137	122,5	106,5	87,5					
EV 20/13	15	20	20	205												188,5	184	180	175	170	161	147,5	132	114,5	94					
EV 20/14	15	20	20	220,5												202,5	198	193,5	188	182,5	172,5	158	141	122	100,5					
EV 20/15	18,5	25	20	237												217,5	212,5	208	202	196	185,5	170,5	152	132	108,5					
EV 20/16	18,5	25	20	252,5												231,5	226	221	215	208,5	197	181	161,5	140	115					
EV 20/17	18,5	25	20	268												245,5	240	234,5	227,5	221	209	191,5	171	148	121,5					

EV 15-20

MATERIAL IN CONTACT WITH THE LIQUID				
Pos.	PARTS DESCRIPTIONS	Type	MATERIAL	
			N version	
			ASTM/AISI	DIN / EN
10.00	Pump casing	Stainless Steel	CF 8M / AISI 316	1.4408
10.02	Filling and draining plug	Stainless Steel	AISI 316	1.4401
10.06	Upper Flange	Stainless Steel	CF 8M / AISI 316	1.4408
20.00	Outer Case	Stainless Steel	AISI 316	1.4401
20.01	Mechanical seal housing	Stainless Steel	CF 8M / AISI 316	1.4408 / 1.4401
20.05	Filling plugs	Stainless Steel	AISI 316	1.4401
30.00	Pump shaft	Stainless Steel	AISI 316	1.4401
30.01	Kit Mechanical seal	Silicon Carbide SiC, Graphite, EPDM, Stainless Steel	-	-
30.02	Mechanical seal fastening kit	Stainless Steel	AISI 316	1.4401
30.03	Kit O-rings	EPDM	-	-
40.00	Stage housing and diffuser	Stainless Steel	AISI 316	1.4401
40.01	Stage Centering outlet	Stainless Steel	AISI 316	1.4401
40.02	Floating neck ring	PTFE	-	-
40.03	Initial stage housing	Stainless Steel	AISI 316	1.4401
40.04	Last Stage with diffuser	Stainless Steel	AISI 316	1.4401
40.06	Stage housing and diffuser with bearing	Stainless Steel / Tungsten carbide	AISI 316	1.4401
50.00	Impeller	Stainless Steel	AISI 316	1.4401
50.01	Impeller spacer	Stainless Steel	AISI 316	1.4401
50.02	Intermediary sleeve	Tungsten Carbide	-	-
50.03	Intermediary sleeve spacer	Stainless Steel	AISI 316	1.4401

EV 30-45

TABLE OF HYDRAULIC PERFORMANCES AT 50Hz

PUMP TYPE	RATED POWER		H1	Q = DELIVERY											
	kW	HP		Bar	l/min 0	250	300	367	417	500	583	667	750	900	1000
			m ³ /h 0		15	18	22	25	30	35	40	45	54	60	65
H = TOTAL HEAD METERS COLUMN OF WATER															
EV 30/1	2,2	3	20	24		20,5	19,5	19	17,5	16	13,5	11			
EV 30/2-2A	4	5,5	20	36		32,5	30,5	29,5	26,5	22,5	18	12,5			
EV 30/2-1A	4	5,5	20	42		37	35,5	34	31,5	27,5	23	18			
EV 30/2	5,5	7,5	20	48,5		42,5	41	39,5	36,5	33,5	29	23,5			
EV 30/3-2A	5,5	7,5	20	60		53	50,5	48	44	38	31,5	23,5			
EV 30/3-1A	7,5	10	20	66,5		58,5	56	54	50	45	38	30			
EV 30/3	7,5	10	20	73		63,5	61	59	55	50	43,5	35,5			
EV 30/4-2A	7,5	10	20	84,5		74	70,5	68	62	55	46	35			
EV 30/4-1A	11	15	20	91,5		81	78	75,5	70	63	54,5	43,5			
EV 30/4	11	15	20	98		86	83	80,5	75	69	60	49,5			
EV 30/5-2A	11	15	20	109,5		97	93	89,5	83	74	63	49,5			
EV 30/5-1A	11	15	10	115,5		102	98	94,5	88	79,5	68,5	55			
EV 30/5	15	20	11	122,5		107	103,5	100	93,5	85,5	75	61,5			
EV 30/6-2A	15	20	11	134		118,5	113,5	109,5	101,5	91	78	61,5			
EV 30/6-1A	15	20	12	140		123	118,5	114,5	106,5	96,5	83,5	67			
EV 30/6	15	20	13	146,5		128	123,5	119,5	111,5	102	89	73			
EV 30/7-2A	15	20	13	158		139	133,5	128,5	119	107	91,5	72,5			
EV 30/7-1A	15	20	14	164		144	138,5	133,5	124	112,5	97	78			
EV 30/7	18,5	25	15	171		149	144	139,5	130	119	103,5	85			
EV 30/8-2A	18,5	25	15	182,5		160	154	148,5	137,5	124	106	84,5			
EV 30/8-1A	18,5	25	15	188,5		165	159	153,5	142,5	129,5	111,5	90			
EV 30/8	18,5	25	15	194,5		169,5	164	158,5	147,5	134,5	117	95,5			
EV 30/9-2A	22	30	17	208,5		184	177	171	159	144	124,5	100,5			
EV 30/9-1A	22	30	17	214,5		189	182,5	176,5	164,5	150	130	106			
EV 30/9	22	30	20	221		194	187,5	181,5	169,5	155,5	136	112			
EV 30/10-2A	22	30	20	233		205	197,5	191	177,5	161	139	112			
EV 30/10-1A	22	30	20	239		210	202,5	196	182,5	166,5	144,5	117,5			
EV 30/10	30	40	20	246,5		217	210	203,5	190,5	175	153,5	126,5			
EV 30/11-2A	30	40	20	258		228,5	220,5	213	198,5	180,5	156,5	127			
EV 30/11-1A	30	40	20	264,5		233,5	225,5	218	204	186	162	133			
EV 30/11	30	40	20	271		238	230,5	223,5	209	192	168	138,5			
EV 30/12-2A	30	40	20	282,5		249,5	241	233	217	197,5	171	139			
EV 30/12-1A	30	40	20	289		254,5	246	238	222,5	203	177	145			
EV 30/12	30	40	20	295		259,5	251	243	227,5	208,5	182,5	150,5			
EV 30/13-2A	30	40	20	307		271	261,5	252,5	235,5	214	185,5	151			
EV 30/13-1A	30	40	20	313		276	266,5	258	240,5	220	191,5	156,5			
EV 30/13	30	40	20	319,5		280,5	271,5	263	246	225,5	197	162,5			
EV 45/1-1A	3	4	20	19						16,5	15,5	14,5	11,5	9,5	7,5
EV 45/1	4	5,5	20	24,5						21,5	21	19,5	17	15,5	13,5
EV 45/2-2A	5,5	7,5	20	38,5						33	31	28,5	23	18,5	14,5
EV 45/2	7,5	10	20	48,5						43	41,5	39	34	30,5	26,5
EV 45/3-2A	11	15	20	63						56	53,5	50	42	36	30
EV 45/3	11	15	20	73,5						65,5	63	60	52,5	47	41
EV 45/4-2A	15	20	8	87,5						77,5	74	69,5	59,5	51	43
EV 45/4	15	20	11	97,5						86,5	84	79,5	69,5	62	54,5
EV 45/5-2A	18,5	25	11	112						99	94,5	89	76,5	66	56
EV 45/5	18,5	25	14	122						108	104,5	99	86,5	77	67,5
EV 45/6-2A	22	30	14	137,5						122	117,5	110,5	95,5	83,5	72
EV 45/6	22	30	17	147,5						131,5	127	121	106	95	83,5
EV 45/7-2A	30	40	17	162,5						145	139,5	132	115	101	87,5
EV 45/7	30	40	20	172,5						154,5	149,5	142,5	125,5	112	99
EV 45/8-2A	30	40	20	187						167	160,5	152	132	116,5	101
EV 45/8	30	40	20	197						176,5	170,5	162,5	142,5	127,5	112,5
EV 45/9-2A	37	50	20	211,5						188,5	181,5	172	149,5	132	114,5
EV 45/9	37	50	20	221,5						198	191,5	182	160	143	126
EV 45/10-2A	37	50	20	235,5						210	202	191,5	166,5	147	127,5
EV 45/10	37	50	20	246						219	212	201,5	177	158	139
EV 45/11-2A	45	60	20	261						233	224,5	213	186	164,5	143,5
EV 45/11	45	60	20	271						242,5	234,5	223,5	196,5	175,5	155
EV 45/12-2A	45	60	20	285,5						254,5	245,5	232,5	203	179,5	156,5
EV 45/12	45	60	20	295,5						264	255,5	243	213,5	191	168,5
EV 45/13-2A	45	60	20	309,5						276	266	252,5	220,5	195	170

EV 30-45

MATERIAL IN CONTACT WITH THE LIQUID						
Pos.	PARTS DESCRIPTIONS	Type	MATERIAL			
			G version		N version	
			ASTM/AISI	DIN / EN	ASTM/AISI	DIN / EN
10.00	Pump casing	Cast Iron / Stainless Steel	A48 Class 35	GJL-250	CF 8M / AISI 316	1.4408
10.02	Draining plug	Stainless Steel	AISI 304	1.4301	AISI 316	1.4401
10.06	Upper Flange	Stainless Steel	CF 8 / AISI 304	1.4308	CF 8M / AISI 316	1.4408
20.00	Outer Case	Stainless Steel	AISI 304	1.4301	AISI 316	1.4401
20.01	Mechanical seal housing	Stainless Steel	CF 8 / AISI 304	1.4308	CF 8M / AISI 316	1.4408
20.05	Filling plugs	Stainless Steel	AISI 304	1.4301	AISI 316	1.4401
30.00	Pump shaft	Stainless Steel	AISI 431	1.4057	AISI 329	1.4460
30.01	Kit Mechanical seal	Silicon Carbide SiC, Graphite, EPDM, Stainless Steel	-	-	-	-
30.02	Mechanical seal fastening kit	Stainless Steel	AISI 316	1.4401	AISI 316	1.4401
30.03	Kit O-rings	EPDM	-	-	-	-
40.00	Stage housing and diffuser	Stainless Steel / Graphite	AISI 304	1.4301	AISI 316	1.4401
40.02	Floating neck ring	PTFE	-	-	-	-
40.05	Stage Centering inlet	Stainless Steel	AISI 316	1.4401	AISI 316	1.4401
40.06	Stage housing and diffuser with bearing	Stainless Steel	AISI 304	1.4301	AISI 316	1.4401
40.07	Flange clamping neck ring	Stainless Steel	AISI 304	1.4301	AISI 316	1.4401
40.08	Spring ring	Stainless Steel	AISI 316	1.4401	AISI 316	1.4401
50.00	Impeller	Stainless Steel	AISI 304	1.4301	AISI 316	1.4401
51.01	Split cone	Stainless Steel	AISI 304	1.4301	AISI 316	1.4401
51.02	Intermediary sleeve nut	Stainless Steel / Tungsten Carbide	AISI 316	1.4401	AISI 316	1.4401
51.03	Journal sleeve	Stainless Steel / Tungsten Carbide	AISI 316	1.4401	AISI 316	1.4401
51.04	Split cone nut	Stainless Steel	AISI 304	1.4301	AISI 316	1.4401
51.05	Intermediate impeller with screw	Stainless Steel	AISI 304	1.4301	AISI 316	1.4401

EV 65-95

TABLE OF HYDRAULIC PERFORMANCES AT 50Hz

PUMP TYPE	RATED POWER		H1 Bar	Q = DELIVERY												
	kW	HP		l/min 0	500	600	700	750	900	1000	1200	1300	1417	1600	1800	1967
				m ³ /h 0	30	36	42	45	54	60	72	78	85	96	108	118
H = TOTAL HEAD METERS COLUMN OF WATER																
EV 65/1-1A	4	5,5	20	19,5	19	18,5	18	17,5	16,5	15,5	12,5	11	9			
EV 65/1	5,5	7,5	20	28	25	24,5	24	23,5	22,5	22	20	18,5	16,5			
EV 65/2-2A	7,5	10	20	39	37,5	36,5	35,5	35	33	31	25	22	17,5			
EV 65/2-1A	11	15	20	48	44,5	43,5	42,5	42	40	38,5	34	31	26,5			
EV 65/2	11	15	20	56,5	51	49,5	48,5	48	46	45	41	38,5	34,5			
EV 65/3-2A	15	20	20	67,5	63,5	62	60,5	59,5	56,5	54	46,5	42	35,5			
EV 65/3-1A	15	20	20	76	69,5	68	66,5	65,5	62,5	60,5	53,5	49,5	43			
EV 65/3	18,5	25	20	84,5	76	74	72,5	71,5	69	67	61,5	57,5	51,5			
EV 65/4-2A	18,5	25	20	95,5	88,5	86	84	83	79	75,5	66	60,5	52			
EV 65/4-1A	22	30	20	105	96	93,5	91,5	90,5	87	84	75,5	70	62			
EV 65/4	22	30	20	113,5	102,5	100	97,5	96,5	92,5	90,5	83	78	70			
EV 65/5-2A	30	40	20	125	116	113	110,5	109	104,5	101	90	83	72,5			
EV 65/5-1A	30	40	20	133,5	122,5	119	116,5	115	110,5	107,5	97,5	90,5	80,5			
EV 65/5	30	40	20	142	129	125,5	122,5	121	116,5	114	105	98,5	88,5			
EV 65/6-2A	30	40	20	153	141,5	137,5	134,5	133	127,5	123	110	102	89,5			
EV 65/6-1A	37	50	20	162	148	144	141	139	133,5	129,5	117,5	109,5	97,5			
EV 65/6	37	50	20	170	154	150	147	145	139,5	136	125	117,5	105,5			
EV 65/7-2A	37	50	20	181,5	166,5	162,5	158,5	156,5	150	145	130,5	120,5	106,5			
EV 65/7-1A	37	50	20	189,5	173	168,5	164,5	162,5	156	151,5	138	128,5	114,5			
EV 65/7	45	60	20	199	180,5	175,5	172	169,5	163,5	159,5	147	138	124			
EV 65/8-2A	45	60	20	210	193	188	184	181,5	174	168,5	152	141,5	125			
EV 65/8-1A	45	60	20	218,5	199,5	194	190	187,5	180	175	159,5	149	133			
EV 65/8	45	60	20	227	206	200	196	193,5	186	181,5	167	157	141			
EV 95/1-1A	5,5	7,5	20	22				21	20,5	20	19	17,5	16,5	13,5	10	6,5
EV 95/1	7,5	10	20	30,5				27,5	26	25,5	24	23,5	22	20	17	13,5
EV 95/2-2A	11	15	20	44,5				43	42	41	38,5	36,5	34	28,5	21,5	15
EV 95/2	15	20	20	62				55,5	53	51,5	49	47,5	45	41	35	28,5
EV 95/3-2A	18,5	25	20	75,5				70,5	68	66,5	62,5	59,5	56	48,5	38,5	28,5
EV 95/3	22	30	20	93,5				84	80,5	78	74	72	69	62,5	53,5	44
EV 95/4-2A	30	40	20	108				100	97	94,5	89	85,5	81	71,5	59	46
EV 95/4	30	40	20	125,5				112,5	108	105	99,5	96,5	92,5	84	72	60
EV 95/5-2A	37	50	20	139				127,5	123,5	120	113,5	109	103,5	92	76	60
EV 95/5	37	50	20	156				140	134,5	130,5	123,5	120	114,5	104,5	89	74
EV 95/6-2A	45	60	20	170,5				156	150,5	146,5	138,5	134	127	113,5	94,5	75,5
EV 95/6	45	60	20	188				169	161,5	157	149	144,5	138,5	126	108	89,5

EV 65-95

MATERIAL IN CONTACT WITH THE LIQUID						
Pos.	PARTS DESCRIPTIONS	Type	MATERIAL			
			G version		N version	
			ASTM/AISI	DIN / EN	ASTM/AISI	DIN / EN
10.00	Pump casing	Cast Iron / Stainless Steel	A48 Class 35	GJL-250	CF 8M / AISI 316	1.4408
10.02	Draining plug	Stainless Steel	AISI 304	1.4301	AISI 316	1.4401
10.06	Upper Flange	Stainless Steel	CF 8 / AISI 304	1.4308	CF 8M / AISI 316	1.4408
20.00	Outer Case	Stainless Steel	AISI 304	1.4301	AISI 316	1.4401
20.01	Mechanical seal housing	Stainless Steel	CF 8 / AISI 304	1.4308	CF 8M / AISI 316	1.4408
20.05	Filling plugs	Stainless Steel	AISI 304	1.4301	AISI 316	1.4401
30.00	Pump shaft	Stainless Steel	AISI 431	1.4057	AISI 329	1.4460
30.01	Kit Mechanical seal	Silicon Carbide SiC, Graphite, EPDM, Stainless Steel	-	-	-	-
30.02	Mechanical seal fastening kit	Stainless Steel	AISI 316	1.4401	AISI 316	1.4401
30.03	Kit O-rings	EPDM	-	-	-	-
40.00	Stage housing and diffuser	Stainless Steel / Graphite	AISI 304	1.4301	AISI 316	1.4401
40.01	Stage Centering outlet	Stainless Steel	CF 8 / AISI 304	1.4308	CF 8M / AISI 316	1.4408
40.02	Floating neck ring	PTFE	-	-	-	-
40.05	Stage Centering inlet	Stainless Steel	AISI 316	1.4401	AISI 316	1.4401
40.06	Stage housing and diffuser with bearing	Stainless Steel	AISI 304	1.4301	AISI 316	1.4401
40.07	Flange clamping neck ring	Stainless Steel	AISI 304	1.4301	AISI 316	1.4401
40.08	Spring ring	Stainless Steel	AISI 316	1.4401	AISI 316	1.4401
50.00	Impeller	Stainless Steel	AISI 304	1.4301	AISI 316	1.4401
51.01	Split cone	Stainless Steel	AISI 304	1.4301	AISI 316	1.4401
51.02	Intermediary sleeve nut	Stainless Steel / Tungsten Carbide	AISI 316	1.4401	AISI 316	1.4401
51.03	Journal sleeve	Stainless Steel / Tungsten Carbide	AISI 316	1.4401	AISI 316	1.4401
51.04	Split cone nut	Stainless Steel	AISI 304	1.4301	AISI 316	1.4401
51.05	Intermediate impeller with screw	Stainless Steel	AISI 304	1.4301	AISI 316	1.4401

Motors – AEG

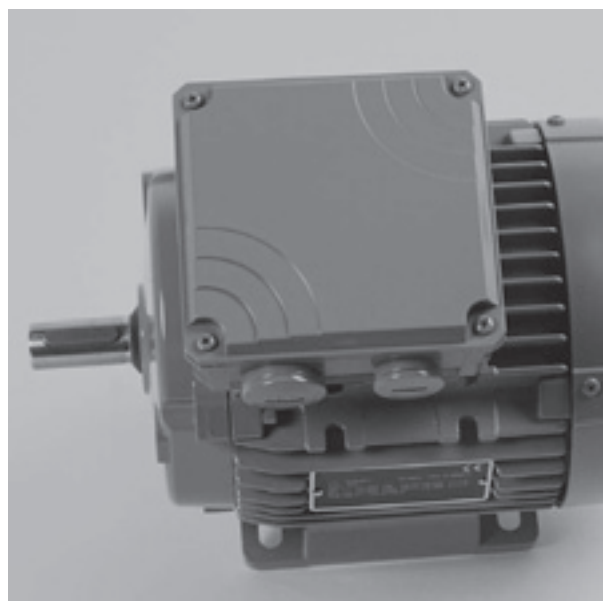

FEATURES

- Protection degree: IP55
- Max ambient temperature: 40°C
- Insulation class: F
- Size B14 up to 4kW, size B5 from 5.5kW and above

SINGLE-PHASE MOTORS

- The range available is especially designed for superior performance and low vibration and noise. The AMM range is ideal for low-inertia applications and the application industry.
- Standard Voltage 230V
- Capacitor inside terminal box

THREE-PHASE MOTORS – ENERGY EFFICIENT

High Efficiency Three-phase Motors IE3 code.

The standard design includes the following basic features to give a high level of flexibility:

- Multi Mount Construction for an easy change of terminal box position
- Terminal box rotates by 90° to allow cable entry from any direction
- Easy-to-change flanges with over-sized and smaller-sized dimensions
- Provision for oil seal at Drive End
- Motors conforming to the higher efficiency standards for Europe, North America and Australia
- Standard Voltage up to 3kW 230/400V, 400/690V from 4kW and above

Single-phase motors designed for range of rated voltage 230V 50Hz

Power kW	Power HP	IEC Size	Construction Design	I _N [A] 230V	min ⁻¹	M _N Nm	η %	cos φ	I _A /I _N	M _A /M _N	Weight Kg
0.37	0.5	71	B14	3.1	2780	1.3	57.6	0.89	3.1	0.8	7.1
0.55	0.75	71	B14	3.9	2740	1.9	69.0	0.89	3.5	0.7	8.5
0.75	1	80	B14	5.3	2800	2.6	65.0	0.95	4.1	0.6	11.4
1.1	1.5	80	B14	6.5	2730	3.8	74.0	0.97	3.6	0.5	11.8
1.5	2	90	B14	9.3	2835	5.1	73.0	0.90	3.9	0.5	17.3
2.2	3	90	B14	14.6	2770	7.6	73.0	0.90	4.3	0.2	19.3

Three-phase motors designed for range of rated voltage 400V 50Hz

	Power kW	Power HP	IEC Size	Construction Design	I _N [A] Δ 230V	I _N [A] Y 400V	I _N [A] Δ 400V	I _N [A] Y 690V	min ⁻¹	M _N Nm	η %	cos φ	I _A /I _N	M _A /M _N	Weight Kg
IE2	0,37	0,5	71	B14	1,7	1,0	-	-	2820	1,3	70,0	0,78	4,7	3,6	5,8
	0,55	0,75	71	B14	2,6	1,5	-	-	2830	1,9	71,0	0,77	4,8	3,2	6,2
IE3	0,75	1	80	B14	2,9	1,7	-	-	2910	2,5	82,0	0,78	8,9	4,7	9,5
	1,1	1,5	80	B14	4,2	2,4	-	-	2870	3,7	82,7	0,76	9,3	5	11,1
	1,5	2	90	B14	5,2	3,0	-	-	2875	5,0	84,2	0,85	8,4	3,6	14,0
	2,2	3	90	B14	8,0	4,6	-	-	2880	7,3	86,5	0,82	9,2	4	16,0
	3	4	100	B14	9,7	5,6	-	-	2900	9,9	87,1	0,89	8,8	5,5	22,8
	4	5,5	112	B14	-	-	8	4,6	2900	13	88,1	0,83	10,7	5,1	26,5
	5,5	7,5	132	B5	-	-	10,2	5,9	2935	17,9	89,2	0,87	11,2	4,2	33,6
	7,5	10	132	B5	-	-	14,4	8,3	2930	24,5	90,1	0,84	10,4	4,5	36,0
	11	15	160	B5	-	-	19,9	11,5	2935	35,8	91,2	0,89	9,7	4,4	62,0
	15	20	160	B5	-	-	26,8	15,5	2915	49,2	91,9	0,88	9,6	3,7	68,0
	18,5	25	160	B5	-	-	33,0	19,1	2950	59,9	92,4	0,88	10,7	4,6	104,0
	22	30	180	B5	-	-	39,4	22,8	2950	71,3	92,7	0,87	10,4	4,5	106,0
	30	40	200	B5	-	-	52,7	30,5	2925	97,9	93,3	0,88	6,7	2,4	276,0
	37	50	200	B5	-	-	63,3	36,6	2930	120,6	93,7	0,90	6,3	2,3	283,0
45	60	225	B5	-	-	78,5	45,4	2930	146,7	94,0	0,88	6,9	2,3	370,0	

New International Efficiency classes of motors – IE code

The new IEC 60034-30:2008 defines worldwide the efficiency classes of motors.

IE1 = Standard Efficiency (comparable to EFF2)

IE2 = High Efficiency (comparable to EFF1)

IE3 = Premium Efficiency

The efficiency levels according to IEC 60034-30 are measured based on the test methods defined in IEC 60034-2-1:2007. The IEC 60034-30 only defines requirements of efficiency classes and aims to create provisions for International consistency. It does not define which motors must be supplied with which efficiency level. This is left to respective regional legislation.

Output kW	IE1 code Standard Efficiency			IE2 code Standard Efficiency			IE3 code Standard Efficiency		
	2 poles	4 poles	6 poles	2 poles	4 poles	6 poles	2 poles	4 poles	6 poles
0.75	72.1	72.1	70.0	77.4	79.6	75.9	80.7	82.5	78.9
1.1	75.0	75.0	72.9	79.6	81.4	78.1	82.7	84.1	81.0
1.5	77.2	77.2	75.2	81.3	82.8	79.8	84.2	85.3	82.5
2.2	79.7	79.7	77.7	83.2	84.3	81.8	85.9	86.7	84.3
3	81.5	81.5	79.7	84.6	85.5	83.3	87.1	87.7	85.6
4	83.1	83.1	81.4	85.8	86.6	84.6	88.1	88.6	86.8
5.5	84.7	84.7	83.1	87.0	87.7	86.0	89.2	89.6	88.0
7.5	86.0	86.0	84.7	88.1	88.7	87.2	90.1	90.4	89.1
11	87.6	87.6	86.4	89.4	89.8	88.7	91.2	91.4	90.3
15	88.7	88.7	87.7	90.3	90.6	89.7	91.9	92.1	91.2
18.5	89.3	89.3	88.6	90.9	91.2	90.4	92.4	92.6	91.7
22	89.9	89.9	89.2	91.3	91.6	90.9	92.7	93.0	92.2
30	90.7	90.7	90.2	92.0	92.3	91.7	93.3	93.6	92.9
37	91.2	91.2	90.8	92.5	92.7	92.2	93.7	93.9	93.3
45	91.7	91.7	91.4	92.9	93.1	92.7	94.0	94.2	93.7

Efficiency values according to IEC 60034-30:2008.

Efficiency standard calculation: IEC 60034-2-1:2007

Noise

The noise level of an electrical machine is determined by measuring the sound pressure level in accordance with curve A of the sound level meter to EN 60651 and is indicated in dB (A). The permitted noise levels of electrical machines are fixed in EN 60034-9 (IEC 34-9). The noise level of our motors is well below these limit values. Air-borne sound measurements are carried out in an anechoic testing chamber to EN 21680-ISO 1680. Speed corresponding to a mains frequency of 50Hz and the number of poles.

Noise levels

The noise values listed below refer to 50Hz at rated voltage with a tolerance of up to + 3 dB(A). Values for pole-changing motors on request. For 60Hz supply values are 3-5 dB(A) higher. Sound pressure level L_{pA} and sound power level LWA for three-phase single-speed motors with dimensions and output ratings to IEC 60072

Frame size	2 pole		4 pole	
	L_{WA}	L_{pA}	L_{WA}	L_{pA}
56	57	48	47	38
63	58	49	47	38
71	61	52	51	42
80	72	60	60	48
90	74	62	61	49
100	78	66	62	50
112	80	68	65	53
132	81	72	71	59
160	87	74	75	62
180	90	77	78	66
200	91	78	80	68
225	92	80	88	76

Mechanical seal specifications

(in accordance with EN 12756)

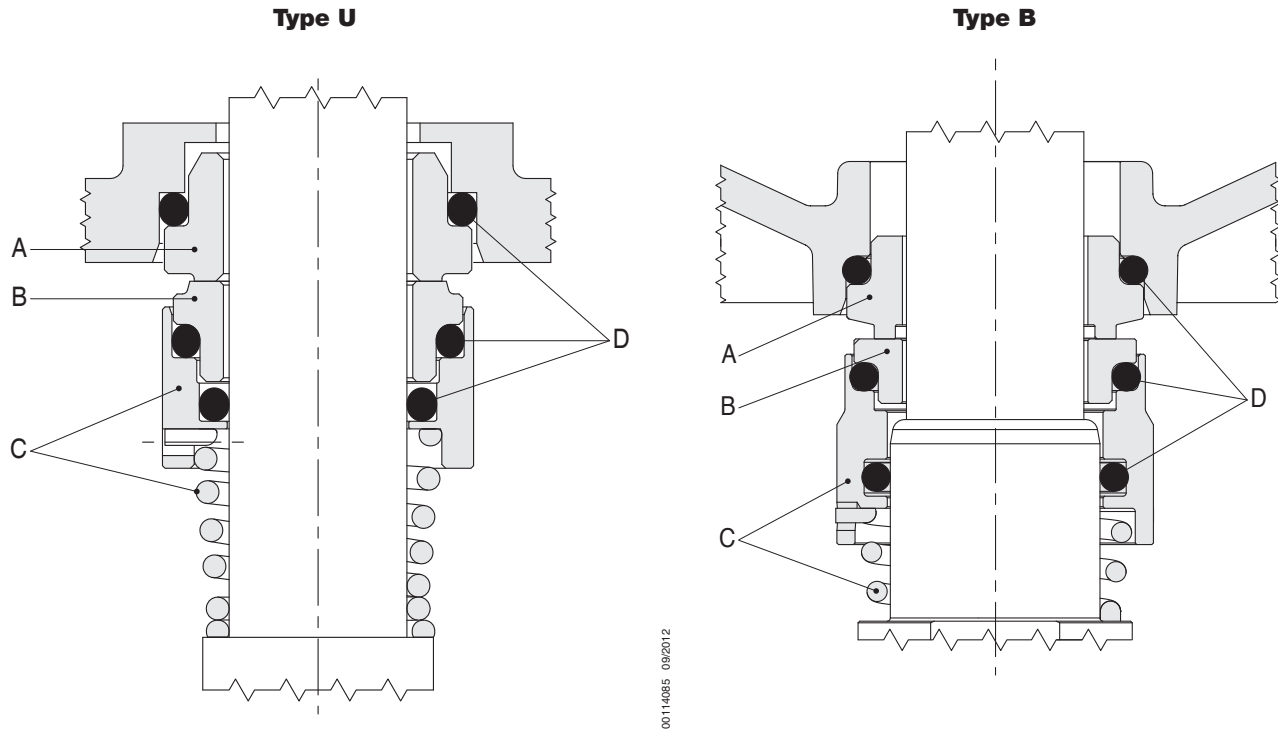

00114055 09/2012

00114115 02/2015

Standard version

Model	Type				Position				Temperature
					A Stationary part	B Rotating part	C Other components	D Elastomers	
E1	B	Q	G	E	Graphite	Silicon carbide	AISI 316	EPDM	-30°C +120°C

Available on request

Model	Type				Position				Temperature (°C)
					A Stationary part	B Rotating part	C Other components	D Elastomers	
E2	Q	Q	G	E	Silicon carbide	Silicon carbide	AISI 316	EPDM	-10°C +120°C
V3	Q	Q	G	V	Silicon carbide	Silicon carbide	AISI 316	FKM	-10°C +120°C
V4	B	Q	G	V	Graphite	Silicon carbide	AISI 316	FKM	-10°C +120°C
E5	U	U	G	E	Tungsten carbide	Tungsten carbide	AISI 316	EPDM	-10°C +120°C

Type	Material
B	Graphite
E	EPDM
G	AISI 316
Q	Silicon carbide
V	FKM
U	Tungsten carbide

Compatibility of fluids and materials

Liquids (aqueous solutions)	Concentration (%)	Temperature Min/Max (°C)	EV models		
			G	I	N
Acetic acid	10 ÷ 40	+18 +70		E1	E1
Aluminium sulfate	10 ÷ 25	+5 +50			E2
Ammonia in water	25	-20 +50		E1	E1
Ammonium sulfate	10	+5 +60			E2
Benzoic acid	4	+20 +80		V4	V4
Caustic soda	25	+5 +70		E2	E2
Chloroform	100	-10 +30		V4	V4
Citric acid	5	+5 +70		E1	E1
Copper sulfate	1 ÷ 20	+5 +30			V3
Deionised, demineralised water	100	+5 +110		E1	E1
Diathermic oil	100	+90 +120	V4	V4	V4
Emulsion oil and water any	10 ÷ 50	+15 +90	V4	V4	V4
Ethylene glycol	10 ÷ 30	-18 +120		E1	E1
ferrous sulfate and ferric sulfate	10	+5 +30			E1
Formic acid	5	+5 +25		E1	E1
Glycerine	100	+90 +120	E1	E1	E1
Hydrochloric acid	2 max	+5 +25			V3
Mineral oil	100	+90 +120	V4	V4	V4
Nitric acid	40	+5 +30		V3	V3
Perchloroethylene	100	-10 +30	V4	V4	V4
Phosphates-polyphosphates	10	+5 +90			E1
Phosphoric acid	5	+5 +30			E1
Propylene glycol	30	-10 +100	V3	V3	V3
Sea water	max 35000 ppm	+2 +60			E1
Sodium bicarbonate (Baking soda)	6	+5 +60			E1
Sodium hypochlorite	1	+5 +25			V3
Sodium nitrate	10	+5 +60	E1		E1
Sodium sulfate	15	+5 +40	E2	E2	E2
Sulphuric acid	2	+5 +25			V4
Tannic acid	20	+5 +50			E1
Tartaric acid	50	+5 +25		V3	V3
Trichloroethylene	100	-10 +40	V4	V4	V4
Vegetable oil	100	+70 +110	E1	E1	E1
Water	100	+5 +120	E1	E1	E1

The table is to be considered as a general guide. It is important to consider the specific working conditions; in particular to consider the concentration of the pumped liquid, the specific weight of the liquid and/or the viscosity, the liquid temperature and pressure. All these conditions are relevant for the motor and pump performance. When pumping dangerous liquids, it is recommended to take safety precautions. For further details, please contact us.

EV Series

Performance Curves and Technical Data

EV 1 - 3 - 6 - 10 - 15 - 20 - 30 - 45 - 65 - 95 50Hz

According to COMMISSION REGULATION (EU) No 547/2012

MEI - Minimum Efficiency Index

In order to achieve a comparable efficiency threshold-value across all legally covered water pumps, an index of pump size, specific speed and rotational speed has been created:

the MEI (Minimum Efficiency Index).

MEI covers best point (BEP), part load (PL) and overload (OL) efficiencies as water pumps may be chosen with safety margins and hence do not run at best efficiency point.

This ensures high and flat efficiency curves and consequently an efficient operation in real life.

MEI means the dimensionless scale unit for hydraulic pump efficiency at BEP, PL and OL.

MEI is a measure for the quality of a pump size in respect to the efficiency.

The higher the value of the MEI is, the better is the pump size in respect to efficiency and the lower is the yearly energy consumption if pumps of this size are installed.

The upper limit of values of the MEI is principally open and depends only on physical and technological constraints. MEI is based on the full impeller diameter. The operation of this water pump with variable duty points may be more efficient and economic when controlled, for example, by the use of a variable speed drive that matches the pump duty to the system.

The efficiency of a pump with a trimmed impeller is usually lower than that of a pump with the full impeller diameter. The trimming of the impeller will adapt the pump to a fixed duty point, leading to reduced energy consumption. The minimum efficiency index (MEI) is based on the full impeller diameter.

For benchmark efficiency graphs, go to www.europump.org/efficiencycharts.

Information on benchmark efficiency is available at www.etechpumps.com.

EV 1

Performance curves 50Hz

MEI ≥ 0,70

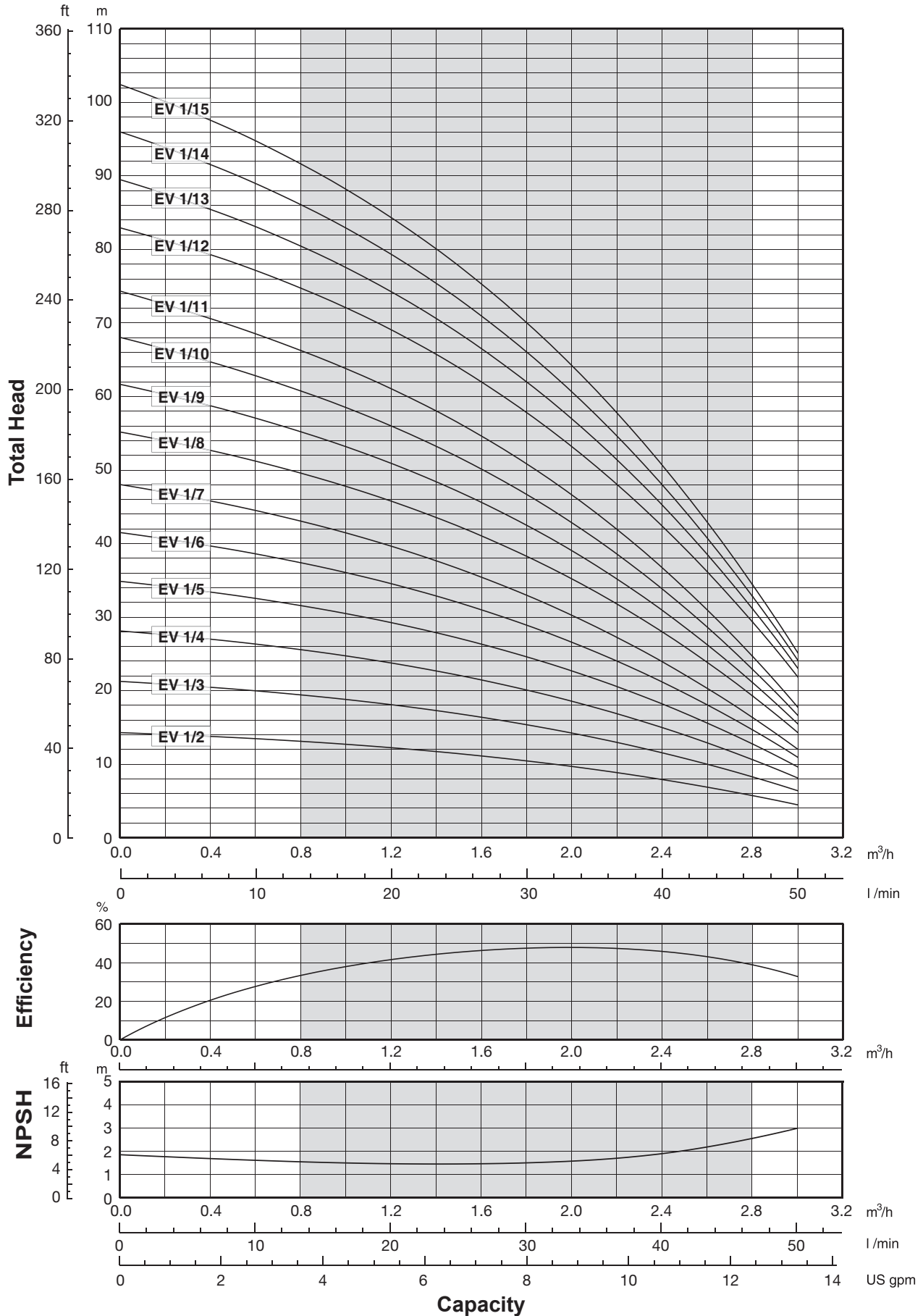

00114116 12/2014

The hydraulic characteristics are guaranteed, according to ISO standard 9906:2012, grade 3B.

It is our policy to continuously develop and improve our products, therefore, we reserve the right to amend specifications without prior notice.



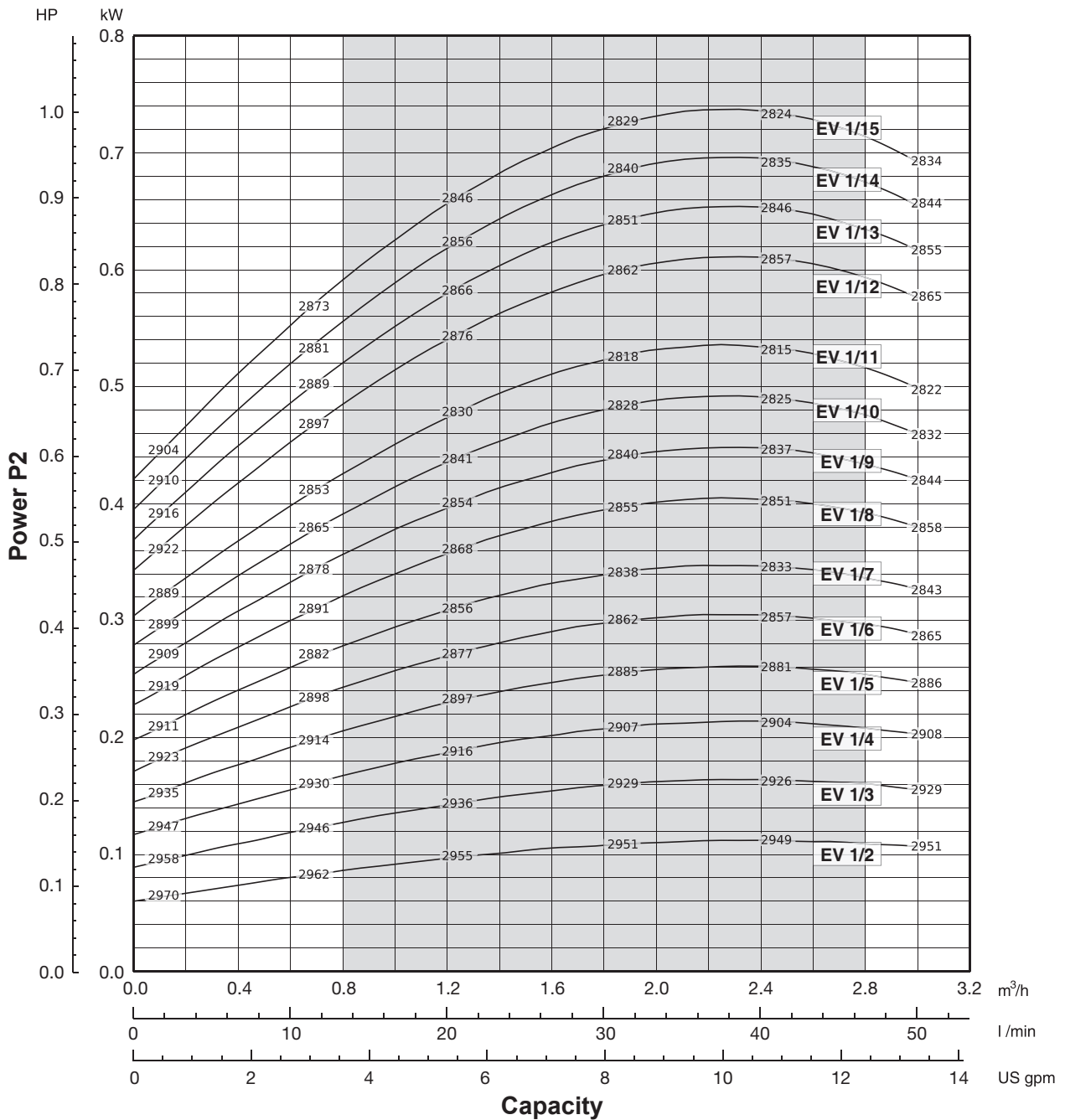

Performance curves of Q, H and P depend on the rpm number according to the following formulae:

$$Q_2 = Q_1 \cdot \left(\frac{n_2}{n_1}\right), \quad H_2 = H_1 \cdot \left(\frac{n_2}{n_1}\right)^2, \quad P_2 = P_1 \cdot \left(\frac{n_2}{n_1}\right)^3, \quad \eta \text{ remains approximately the same.}$$

The rpm number related to the performance curves (Q-H-P) is indicated in the power chart.

Performance curves (Q-H-P) will change in case a motor with rpm number different from indicated values is used.

Q=Capacity, H=Head, P=Power, η =Efficiency

00114116 12/2014

Performance curves 50Hz

MEI ≥ 0,70

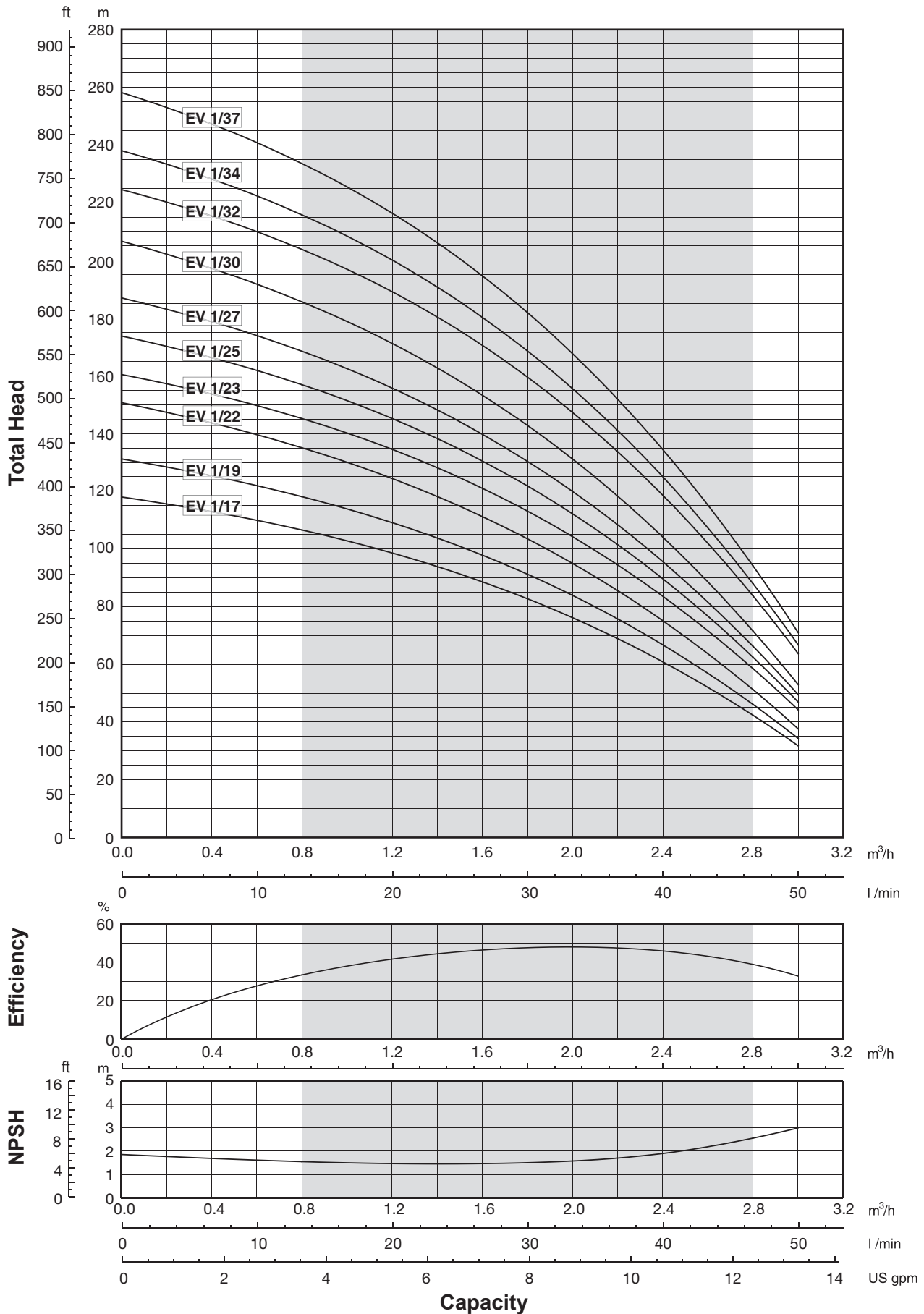

00114117 09/2015

The hydraulic characteristics are guaranteed, according to ISO standard 9906:2012, grade 3B.

It is our policy to continuously develop and improve our products, therefore, we reserve the right to amend specifications without prior notice.



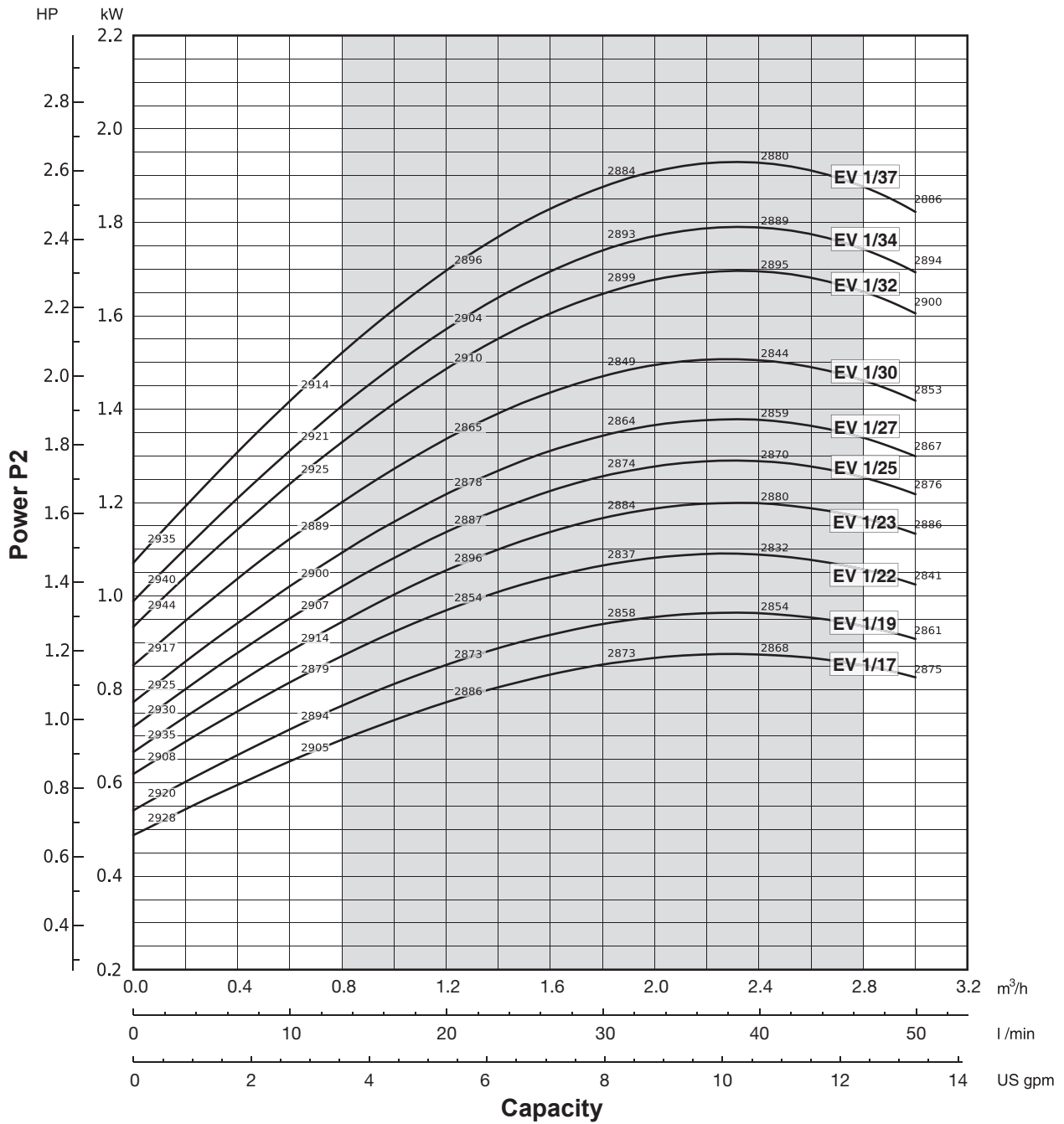

Performance curves of Q, H and P depend on the rpm number according to the following formulae:

$$Q_2 = Q_1 \cdot \left(\frac{n_2}{n_1}\right), \quad H_2 = H_1 \cdot \left(\frac{n_2}{n_1}\right)^2, \quad P_2 = P_1 \cdot \left(\frac{n_2}{n_1}\right)^3, \quad \eta \text{ remains approximately the same.}$$

The rpm number related to the performance curves (Q-H-P) is indicated in the power chart.

Performance curves (Q-H-P) will change in case a motor with rpm number different from indicated values is used.

Q=Capacity, H=Head, P=Power, η =Efficiency

00114117 03/2015

Technical data 50Hz

F version

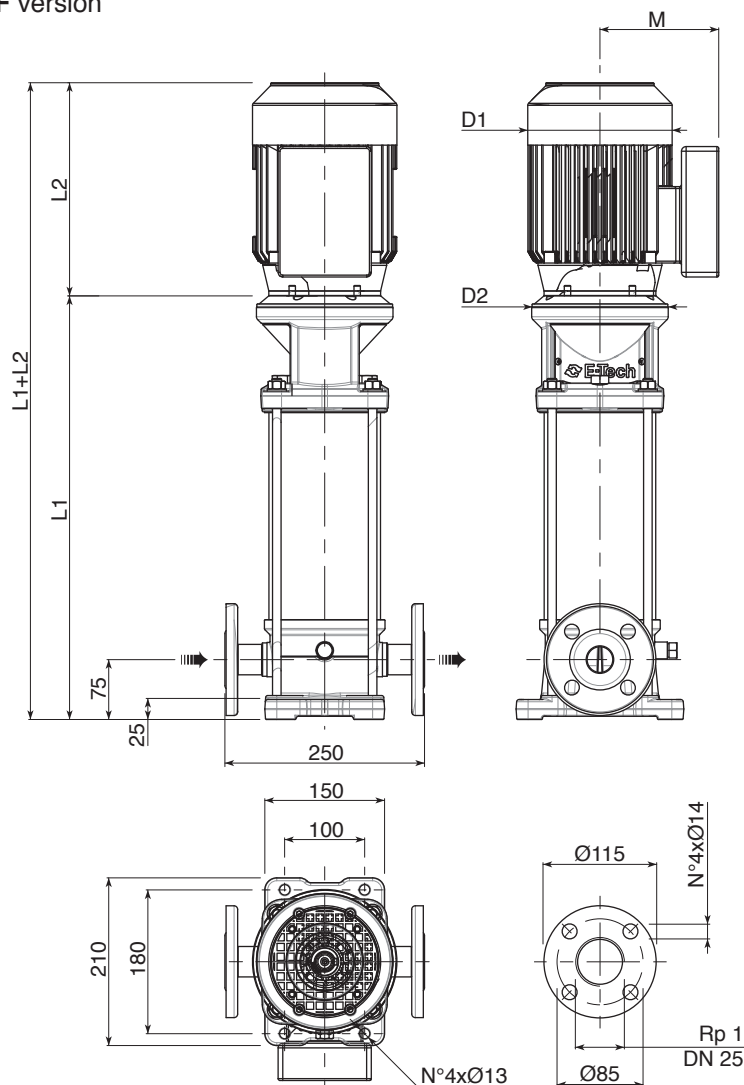

F version Round flanges on body type PN25: the pump is supplied without counterflanges (Optional accessories, including bolts and joints).

T version

Available from EV1/2 to EV1/23

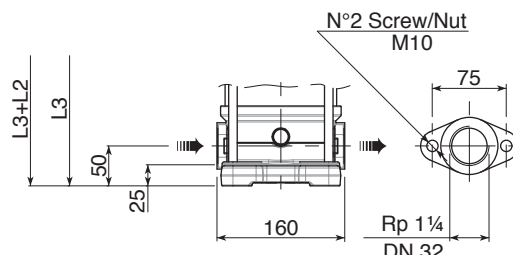

T version Oval flanges on body type PN16: the pump is supplied without threaded oval counter flanges (Optional accessories, including bolts and joints).

V version

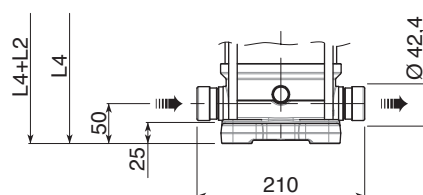

V version Connections with rapid fittings type "Victaulic": the pump is supplied without the collars (Optional accessories).

C version

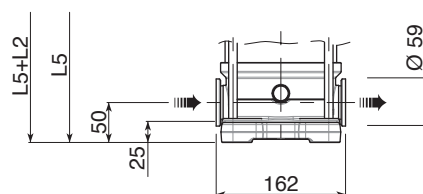

C version Connections with round fittings type Clamp-FlexiClamp: the pump is supplied without collars (Optional accessories).

011.401.411 02/2015

Pump Model	Motor		Dimensions (mm)									Weight (kg)			
	kW	Dim	L1 F	L2		L3 T	L4 V	L5 C	M		D1		D2	Pump	Electric Pump
				1-PHASE	3-PHASE				1-PHASE	3-PHASE	1-PHASE	3-PHASE			
EV 1/2	0,37	71	312,5	215	215	287,5	287,5	287,5	129	112	142	142	170	15	20,8
EV 1/3	0,37	71	335	215	215	310	310	310	129	112	142	142	170	15	20,8
EV 1/4	0,37	71	357,5	215	215	332,5	332,5	332,5	129	112	142	142	170	15,5	21,3
EV 1/5	0,37	71	380	215	215	355	355	355	129	112	142	142	170	16	21,8
EV 1/6	0,37	71	402,5	215	215	377,5	377,5	377,5	129	112	142	142	170	16,5	22,3
EV 1/7	0,37	71	425	215	215	400	400	400	129	112	142	142	170	17	22,8
EV 1/8	0,55	71	447,5	215	215	422,5	422,5	422,5	129	112	142	142	170	17,5	23,7
EV 1/9	0,55	71	470	215	215	445	445	445	129	112	142	142	170	18	24,2
EV 1/10	0,55	71	492,5	215	215	467,5	467,5	467,5	129	112	142	142	170	18,5	24,7
EV 1/11	0,55	71	515	215	215	490	490	490	129	112	142	142	170	19	25,2
EV 1/12	0,75	80	537,5	232	232	512,5	512,5	512,5	150	129	160	160	170	19,5	29
EV 1/13	0,75	80	560	232	232	535	535	535	150	129	160	160	170	20	29,5
EV 1/14	0,75	80	582,5	232	232	557,5	557,5	557,5	150	129	160	160	170	20,5	30
EV 1/15	0,75	80	605	232	232	580	580	580	150	129	160	160	170	21	30,5
EV 1/17	1,1	80	650	232	232	625	625	625	150	129	160	160	170	22	33,1
EV 1/19	1,1	80	695	232	232	670	670	670	150	129	160	160	170	22,5	33,6
EV 1/22	1,1	80	762,5	232	232	737,5	737,5	737,5	150	129	160	160	170	24	35,1
EV 1/23	1,5	90	795	267	267	770	770	770	160	138	180	180	170	25	39
EV 1/25	1,5	90	840	267	267	-	815	815	160	138	180	180	170	26	40
EV 1/27	1,5	90	885	267	267	-	860	860	160	138	180	180	170	27	41
EV 1/30	1,5	90	952,5	267	267	-	927,5	927,5	160	138	180	180	170	28,5	42,5
EV 1/32	2,2	90	997,5	267	267	-	972,5	972,5	160	138	180	180	170	29	45
EV 1/34	2,2	90	1042,5	267	267	-	1017,5	1017,5	160	138	180	180	170	30	46
EV 1/37	2,2	90	1110	267	267	-	1085	1085	160	138	180	180	170	31,5	47,5

EV 3

Performance curves 50Hz

MEI ≥ 0,70

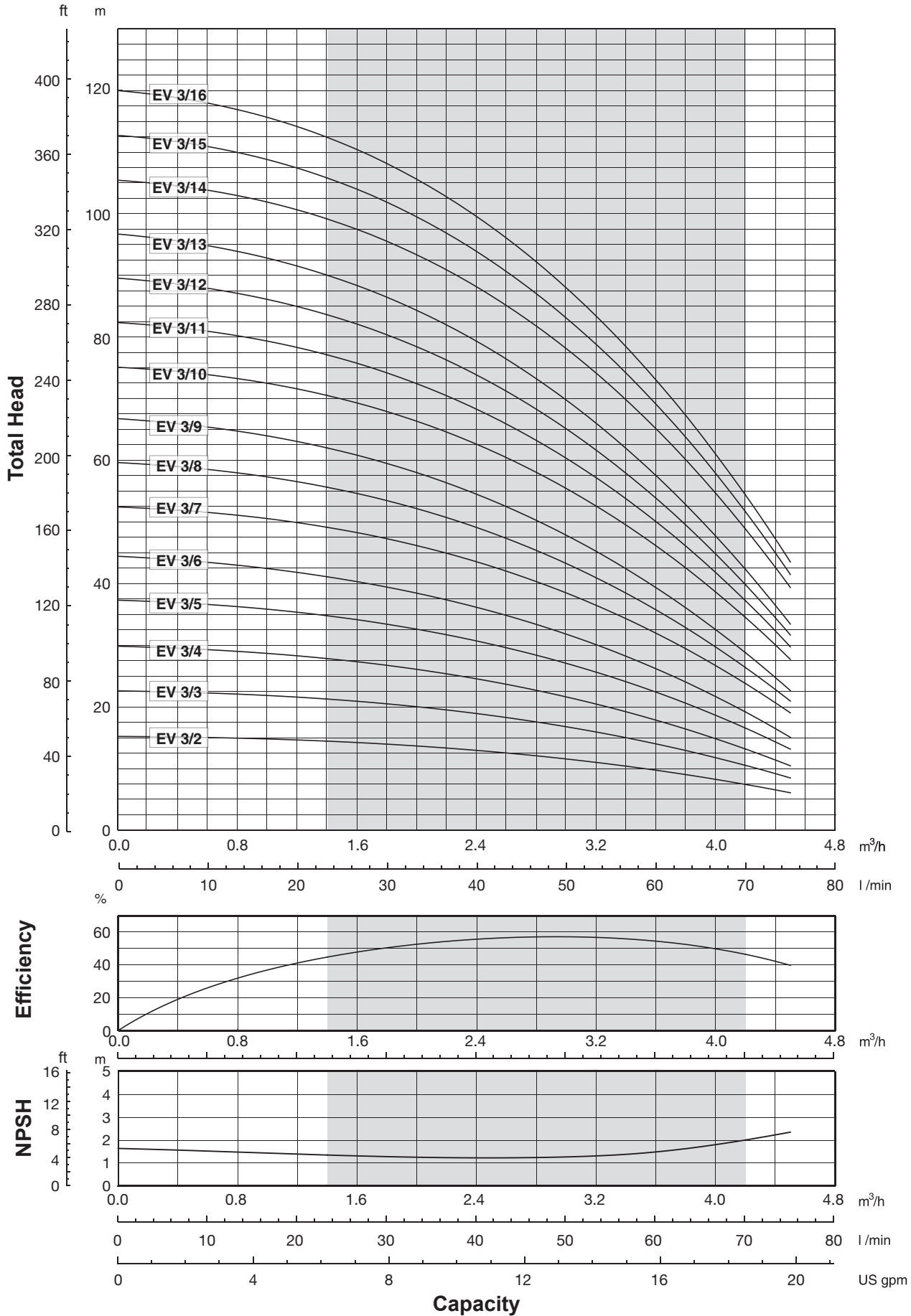

00114118 12/2014

The hydraulic characteristics are guaranteed, according to ISO standard 9906:2012, grade 3B.

It is our policy to continuously develop and improve our products, therefore, we reserve the right to amend specifications without prior notice.



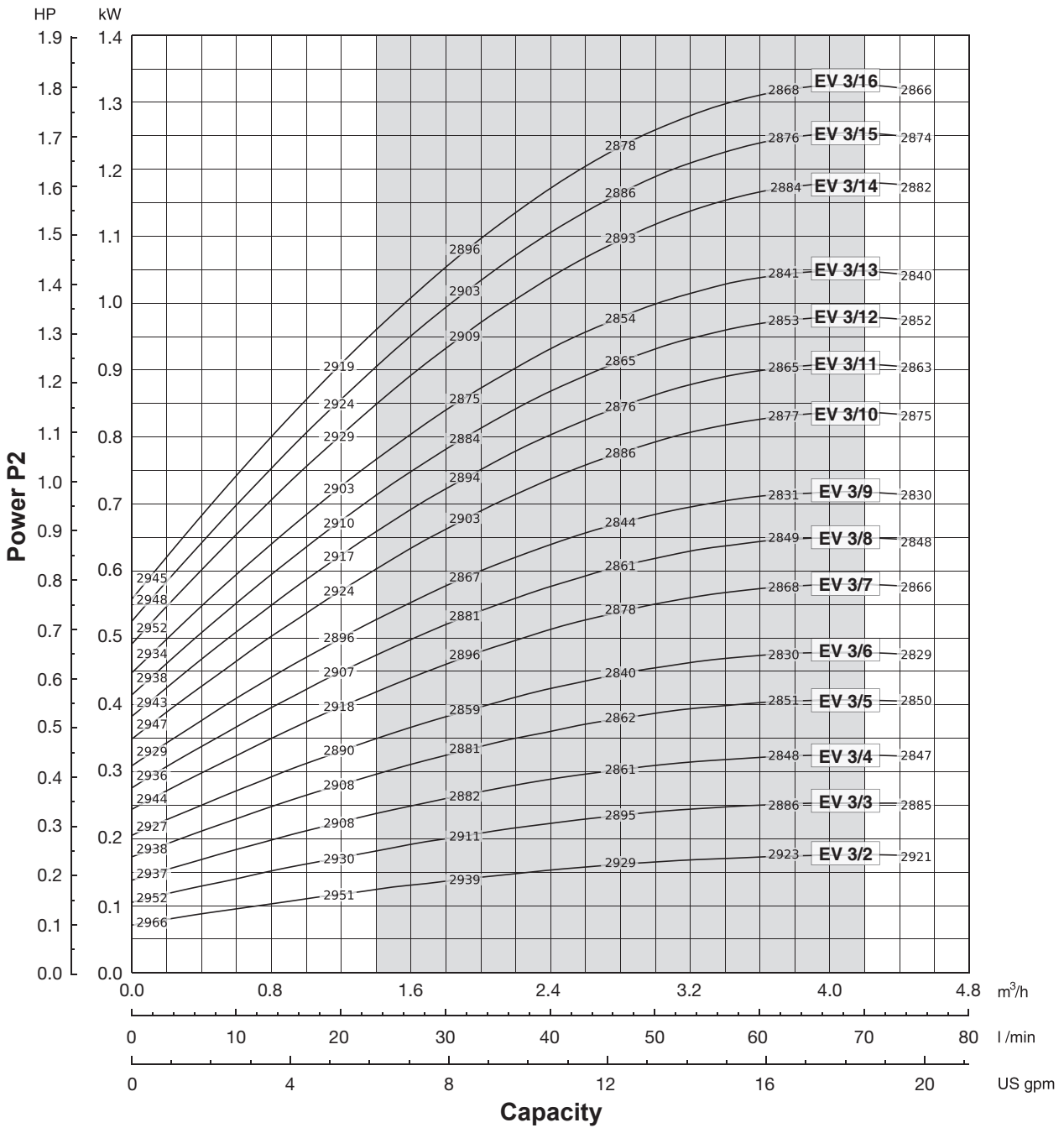

Performance curves of Q, H and P depend on the rpm number according to the following formulae:

$$Q_2 = Q_1 \cdot \left(\frac{n_2}{n_1}\right), \quad H_2 = H_1 \cdot \left(\frac{n_2}{n_1}\right)^2, \quad P_2 = P_1 \cdot \left(\frac{n_2}{n_1}\right)^3, \quad \eta \text{ remains approximately the same.}$$

The rpm number related to the performance curves (Q-H-P) is indicated in the power chart.

Performance curves (Q-H-P) will change in case a motor with rpm number different from indicated values is used.

Q=Capacity, H=Head, P=Power, η=Efficiency

00114118 12/2014

Performance curves 50Hz

MEI ≥ 0,70

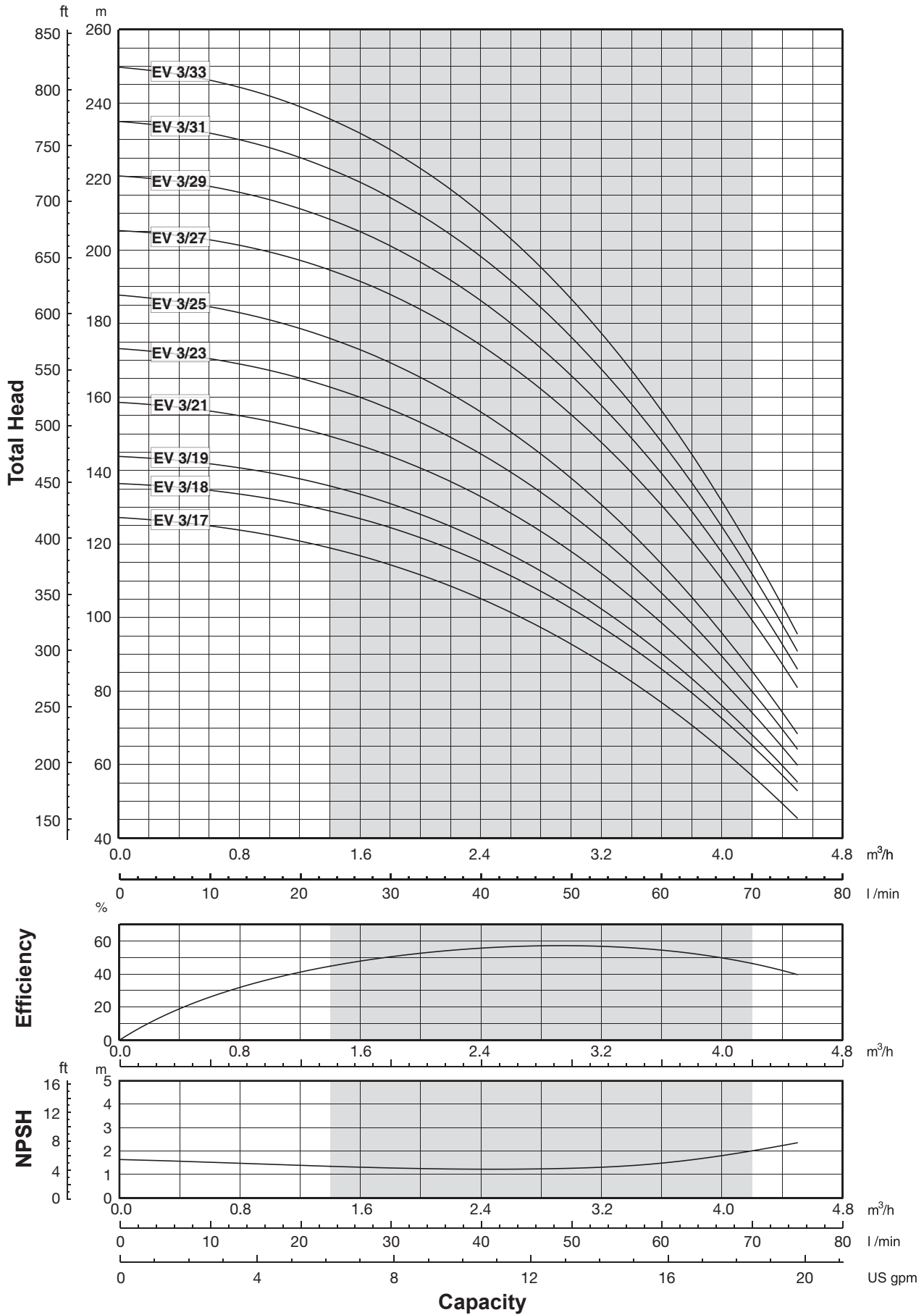

00114119 12/2014

The hydraulic characteristics are guaranteed, according to ISO standard 9906:2012, grade 3B.

It is our policy to continuously develop and improve our products, therefore, we reserve the right to amend specifications without prior notice.

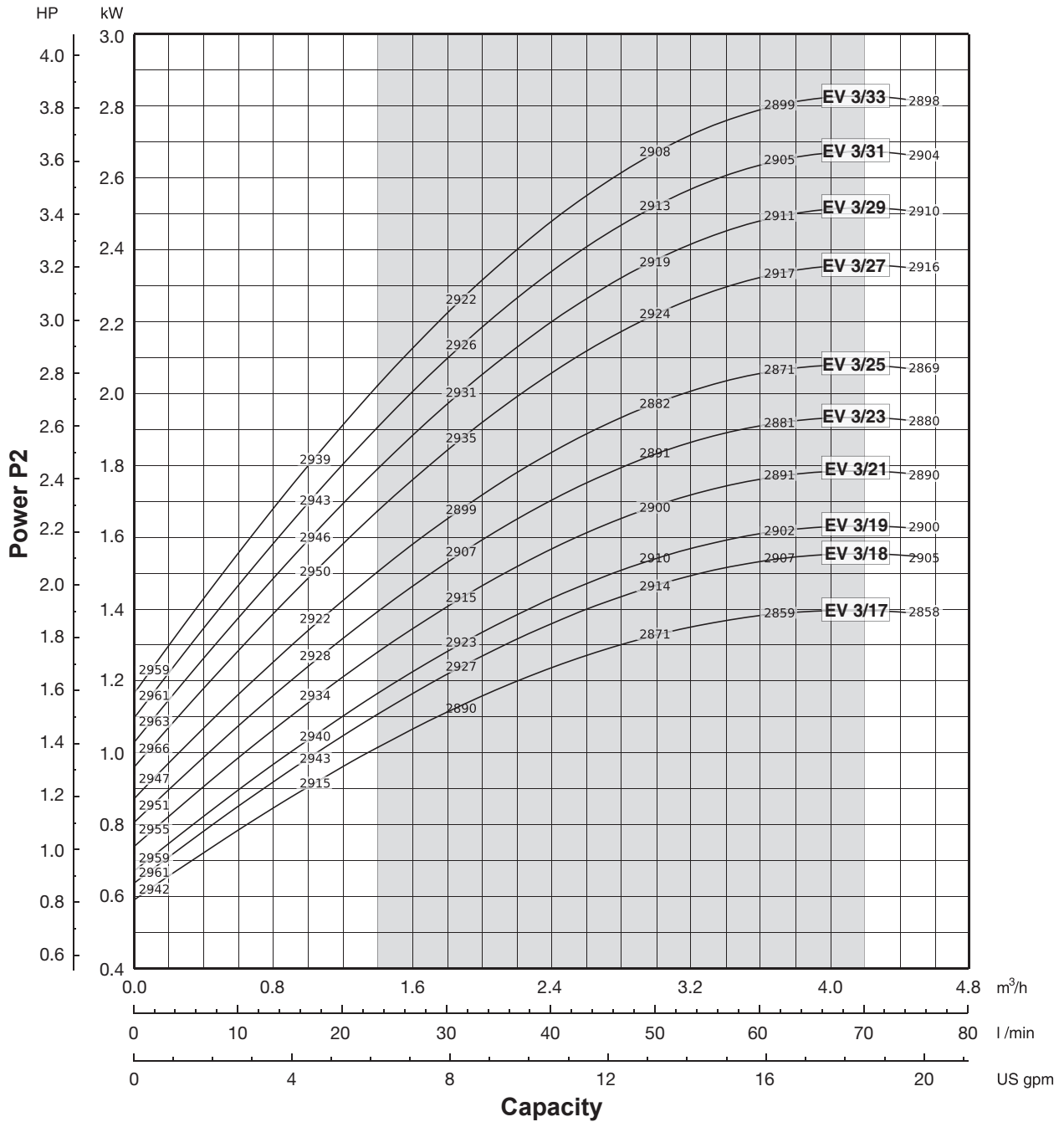

Performance curves of Q, H and P depend on the rpm number according to the following formulae:

$$Q_2 = Q_1 \cdot \left(\frac{n_2}{n_1}\right), \quad H_2 = H_1 \cdot \left(\frac{n_2}{n_1}\right)^2, \quad P_2 = P_1 \cdot \left(\frac{n_2}{n_1}\right)^3, \quad \eta \text{ remains approximately the same.}$$

The rpm number related to the performance curves (Q-H-P) is indicated in the power chart.

Performance curves (Q-H-P) will change in case a motor with rpm number different from indicated values is used.

Q=Capacity, H=Head, P=Power, η=Efficiency

00114119 12/2014

Technical data 50Hz

F version

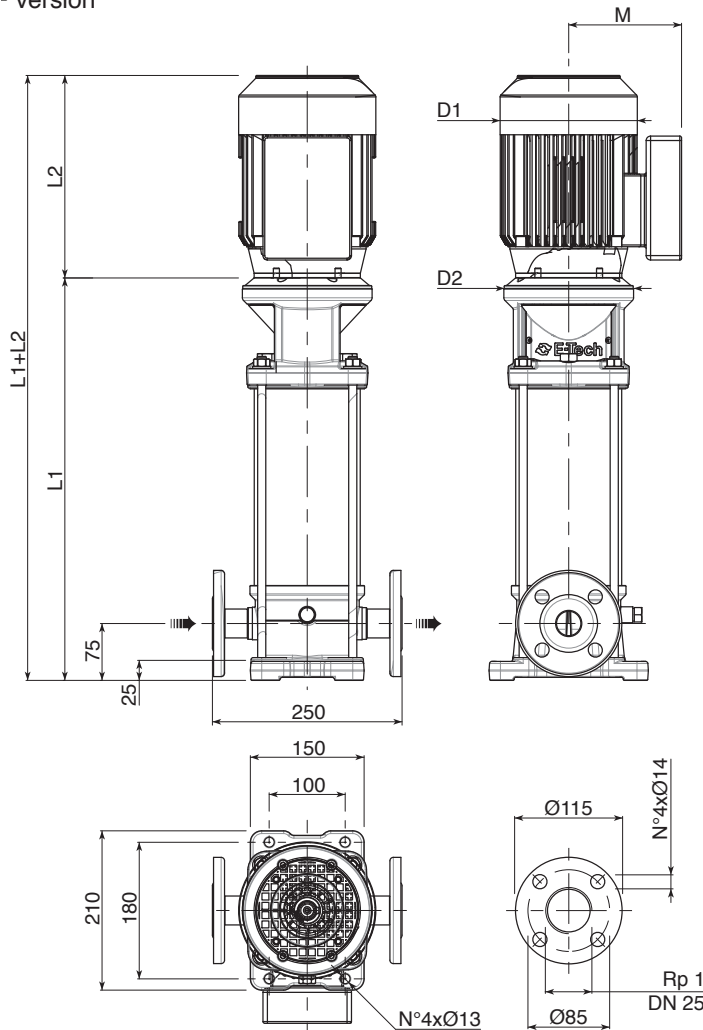

F version Round flanges on body type PN25: the pump is supplied without counterflanges (Optional accessories, including bolts and joints).

T version

Available from EV3/2 to EV3/21

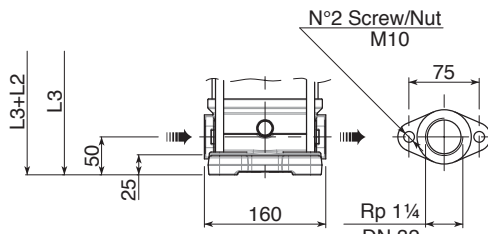

T version Oval flanges on body type PN16: the pump is supplied without threaded oval counter flanges (Optional accessories, including bolts and joints).

V version

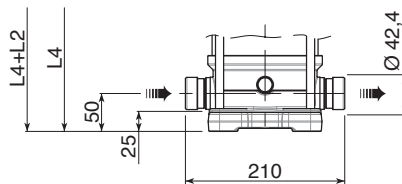

V version Connections with rapid fittings type "Victaulic": the pump is supplied without the collars (Optional accessories).

C version

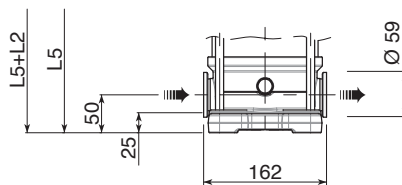

C version Connections with round fittings type Clamp-FlexiClamp: the pump is supplied without collars (Optional accessories)

11-01-11 02/2015

Pump Model	Motor		Dimensions (mm)										Weight (kg)		
	kW	Dim	L1 F	L2		L3 T	L4 V	L5 C	M		D1		D2	Pump	Electric Pump
				1-PHASE	3-PHASE				1-PHASE	3-PHASE	1-PHASE	3-PHASE			
EV 3/2	0,37	71	312,5	215	215	287,5	287,5	287,5	129	112	142	142	170	15	20,8
EV 3/3	0,37	71	335	215	215	310	310	310	129	112	142	142	170	15	20,8
EV 3/4	0,37	71	357,5	215	215	332,5	332,5	332,5	129	112	142	142	170	15,5	21,3
EV 3/5	0,55	71	380	215	215	355	355	355	129	112	142	142	170	16	22,2
EV 3/6	0,55	71	402,5	215	215	377,5	377,5	377,5	129	112	142	142	170	16,5	22,7
EV 3/7	0,75	80	425	232	232	400	400	400	150	129	160	160	170	17	26,5
EV 3/8	0,75	80	447,5	232	232	422,5	422,5	422,5	150	129	160	160	170	17,5	27
EV 3/9	0,75	80	470	232	232	445	445	445	150	129	160	160	170	18	27,5
EV 3/10	1,1	80	492,5	232	232	467,5	467,5	467,5	150	129	160	160	170	18,5	29,6
EV 3/11	1,1	80	515	232	232	490	490	490	150	129	160	160	170	19	30,1
EV 3/12	1,1	80	537,5	232	232	512,5	512,5	512,5	150	129	160	160	170	19,5	30,6
EV 3/13	1,1	80	560	232	232	535	535	535	150	129	160	160	170	20	31,1
EV 3/14	1,5	90	592,5	267	267	567,5	567,5	567,5	160	138	180	180	170	21	35
EV 3/15	1,5	90	615	267	267	590	590	590	160	138	180	180	170	21,5	35,5
EV 3/16	1,5	90	637,5	267	267	612,5	612,5	612,5	160	138	180	180	170	22	36
EV 3/17	1,5	90	660	267	267	635	635	635	160	138	180	180	170	22,5	36,5
EV 3/18	2,2	90	682,5	267	267	657,5	657,5	657,5	160	138	180	180	170	23	39
EV 3/19	2,2	90	705	267	267	680	680	680	160	138	180	180	170	23,5	39,5
EV 3/21	2,2	90	750	267	267	725	725	725	160	138	180	180	170	24	40
EV 3/23	2,2	90	795	267	267	-	770	770	160	138	180	180	170	25	41
EV 3/25	2,2	90	840	267	267	-	815	815	160	138	180	180	170	26	42
EV 3/27	3	100	895	-	290	-	870	870	-	138	-	180	170	27,5	45,5
EV 3/29	3	100	940	-	290	-	915	915	-	138	-	180	170	28,5	46,5
EV 3/31	3	100	985	-	290	-	960	960	-	138	-	180	170	29,5	47,5
EV 3/33	3	100	1030	-	290	-	1005	1005	-	138	-	180	170	30,5	48,5

EV 6

Performance curves 50Hz

MEI ≥ 0,70

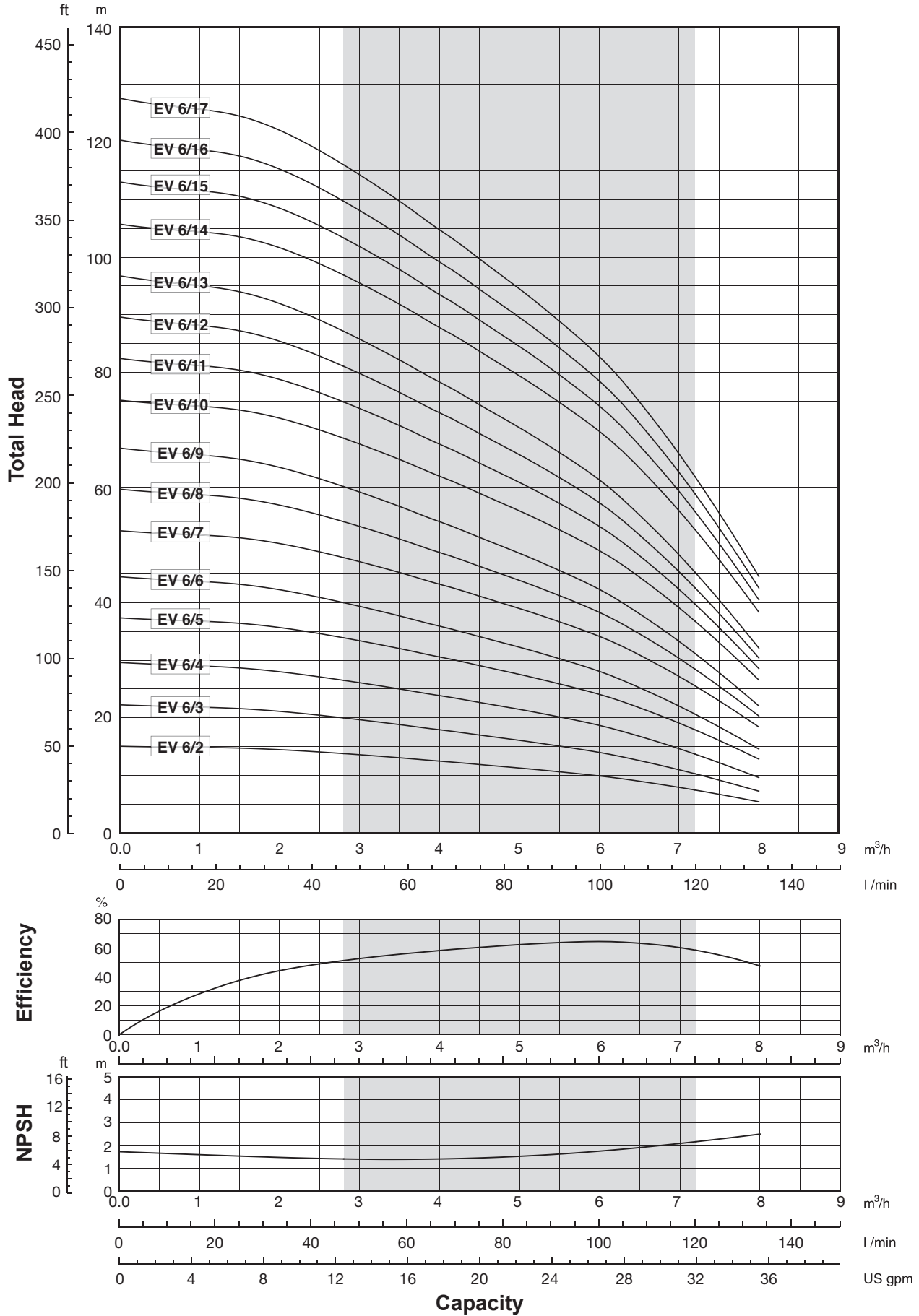

00114140 07/2015

The hydraulic characteristics are guaranteed, according to ISO standard 9906:2012, grade 3B.

It is our policy to continuously develop and improve our products, therefore, we reserve the right to amend specifications without prior notice.

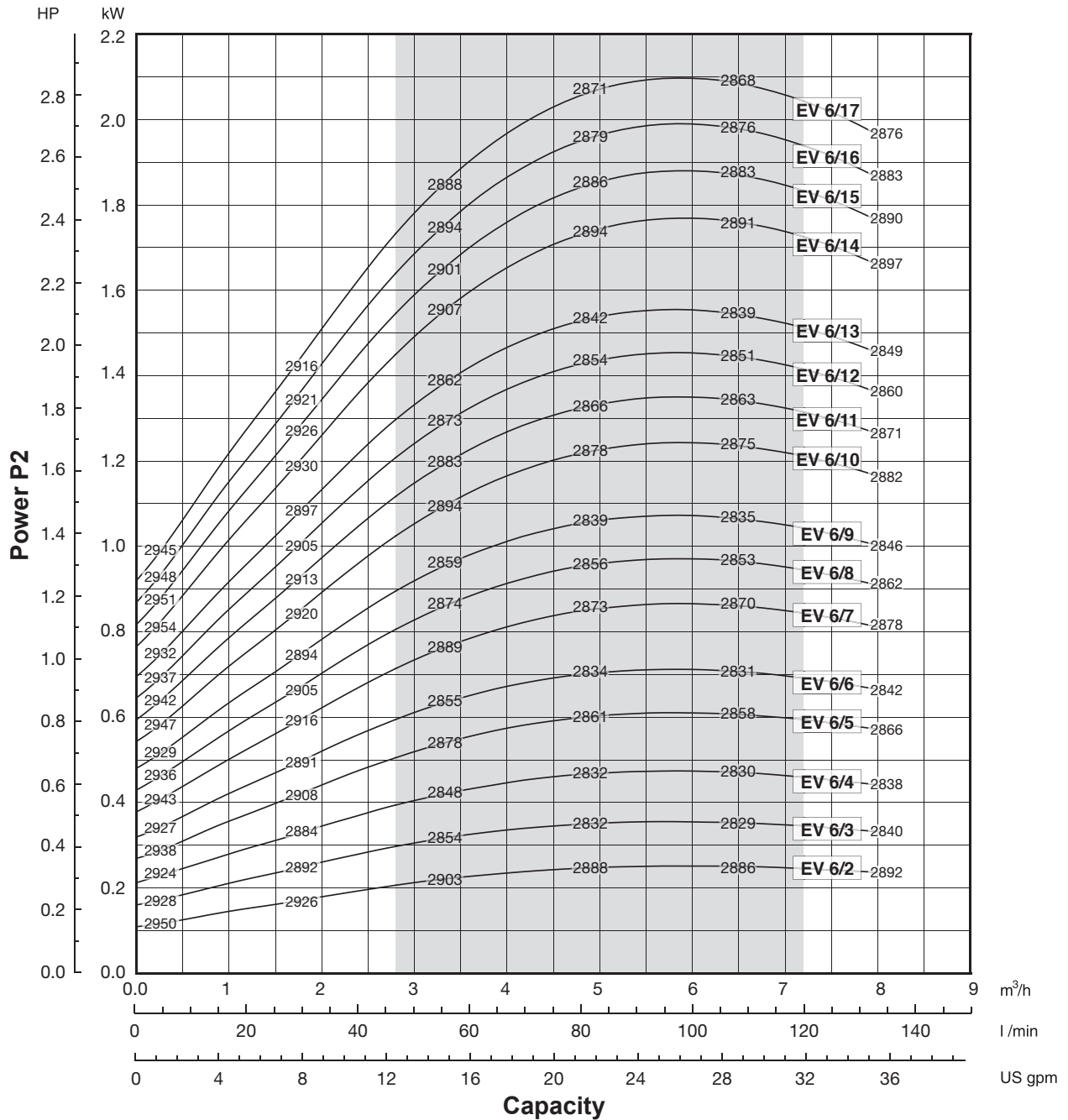

Performance curves of Q, H and P depend on the rpm number according to the following formulae:

$$Q_2 = Q_1 \cdot \left(\frac{n_2}{n_1}\right), \quad H_2 = H_1 \cdot \left(\frac{n_2}{n_1}\right)^2, \quad P_2 = P_1 \cdot \left(\frac{n_2}{n_1}\right)^3, \quad \eta \text{ remains approximately the same.}$$

The rpm number related to the performance curves (Q-H-P) is indicated in the power chart.

Performance curves (Q-H-P) will change in case a motor with rpm number different from indicated values is used.

Q=Capacity, H=Head, P=Power, η=Efficiency

Performance curves 50Hz

MEI ≥ 0,70

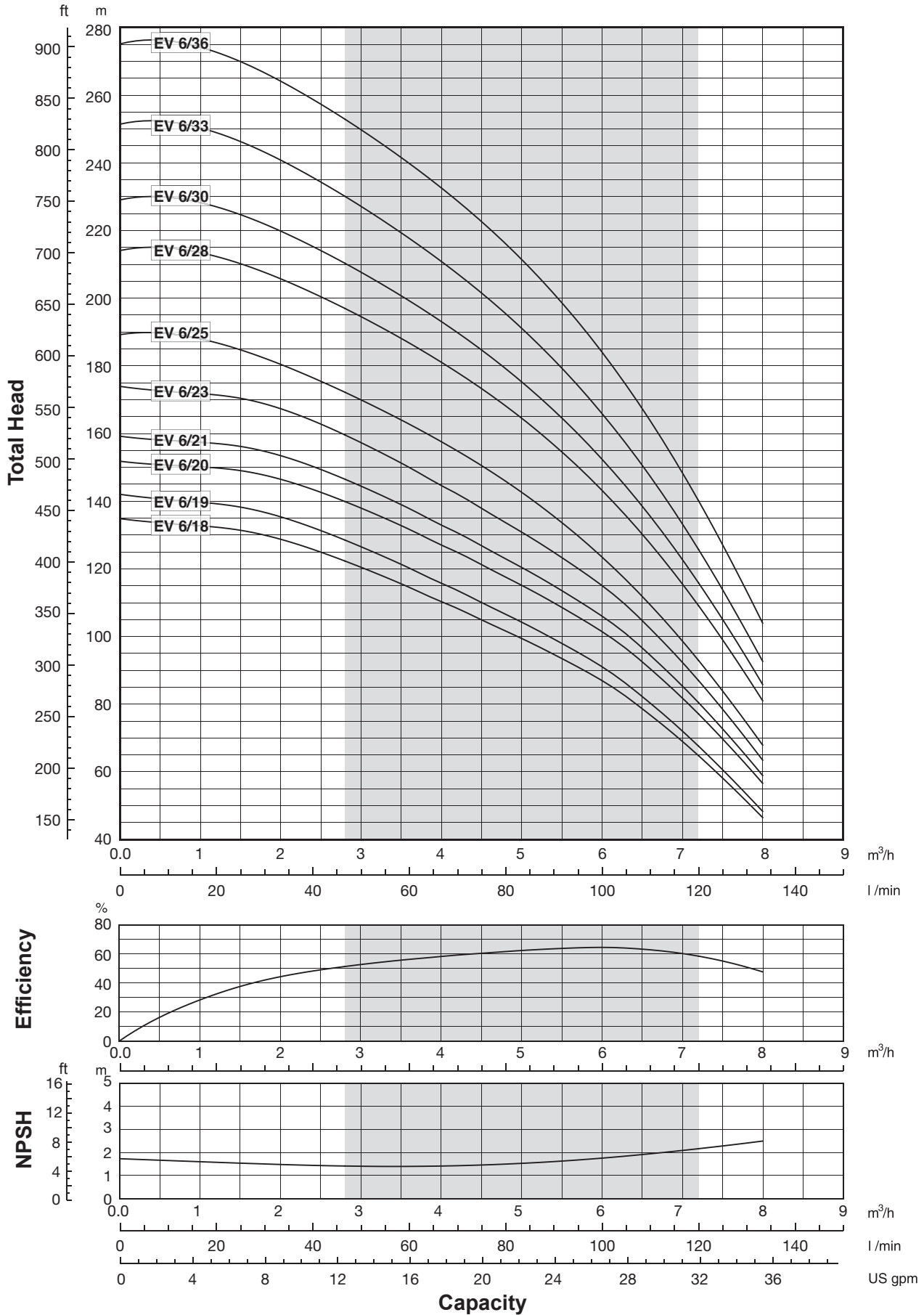

00114141 07/2015

The hydraulic characteristics are guaranteed, according to ISO standard 9906:2012, grade 3B.

It is our policy to continuously develop and improve our products, therefore, we reserve the right to amend specifications without prior notice.



Technical data 50Hz

F version

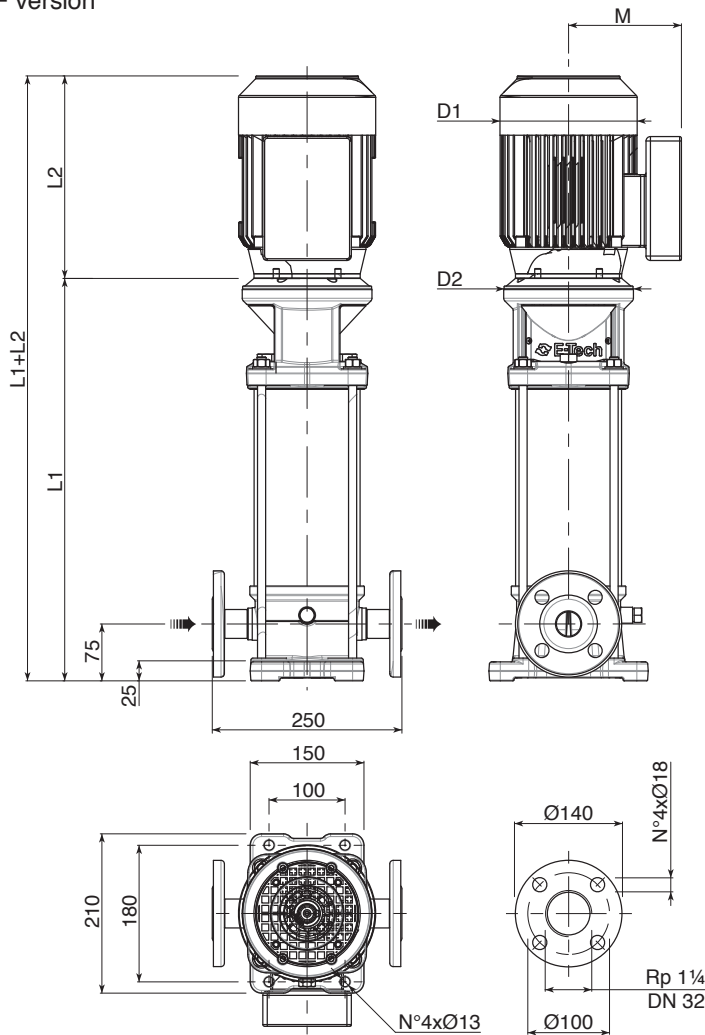

F version Round flanges on body type PN25: the pump is supplied without counterflanges (Optional accessories, including bolts and joints).

T version

Available from EV6/2 to EV6/21

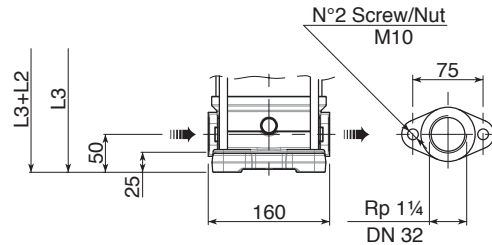

T version Oval flanges on body type PN16: the pump is supplied without threaded oval counter flanges (Optional accessories, including bolts and joints).

V version

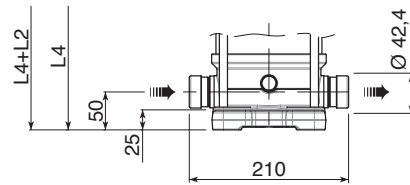

V version Connections with rapid fittings type "Victaulic": the pump is supplied without the collars (Optional accessories).

C version

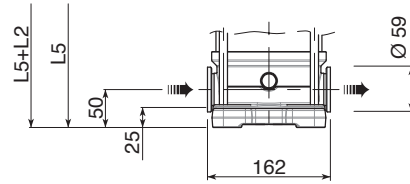

C version Connections with round fittings type Clamp-FlexiClamp: the pump is supplied without collars (Optional accessories).

0011401411 02/2015

Pump Model	Motor		Dimensions (mm)									Weight (kg)			
	kW	Dim	L1 F	L2 1-PHASE	L2 3-PHASE	L3 T	L4 V	L5 C	M 1-PHASE	M 3-PHASE	D1 1-PHASE	D1 3-PHASE	D2	Pump	Electric
EV 6/2	0,37	71	319,5	215	215	294,5	294,5	294,5	129	112	142	142	170	15	20,8
EV 6/3	0,37	71	345,5	215	215	320,5	320,5	320,5	129	112	142	142	170	15,5	21,3
EV 6/4	0,55	71	371,5	215	215	346,5	346,5	346,5	129	112	142	142	170	16	22,2
EV 6/5	0,75	80	397,5	232	232	372,5	372,5	372,5	150	129	160	160	170	16,5	26
EV 6/6	0,75	80	423,5	232	232	398,5	398,5	398,5	150	129	160	160	170	17,5	27
EV 6/7	1,1	80	449,5	232	232	424,5	424,5	424,5	150	129	160	160	170	18	29,1
EV 6/8	1,1	80	475,5	232	232	450,5	450,5	450,5	150	129	160	160	170	18,5	29,6
EV 6/9	1,1	80	501,5	232	232	476,5	476,5	476,5	150	129	160	160	170	19	30,1
EV 6/10	1,5	90	537,5	267	267	512,5	512,5	512,5	160	138	180	180	170	20	34
EV 6/11	1,5	90	563,5	267	267	538,5	538,5	538,5	160	138	180	180	170	20,5	34,5
EV 6/12	1,5	90	589,5	267	267	564,5	564,5	564,5	160	138	180	180	170	21	35
EV 6/13	1,5	90	615,5	267	267	590,5	590,5	590,5	160	138	180	180	170	21,5	35,5
EV 6/14	2,2	90	641,5	267	267	616,5	616,5	616,5	160	138	180	180	170	22	38
EV 6/15	2,2	90	667,5	267	267	642,5	642,5	642,5	160	138	180	180	170	22,5	38,5
EV 6/16	2,2	90	693,5	267	267	668,5	668,5	668,5	160	138	180	180	170	23	39
EV 6/17	2,2	90	719,5	267	267	694,5	694,5	694,5	160	138	180	180	170	23,5	39,5
EV 6/18	2,2	90	745,5	267	267	720,5	720,5	720,5	160	138	180	180	170	24	40
EV 6/19	2,2	90	771,5	267	267	746,5	746,5	746,5	160	138	180	180	170	24,5	40,5
EV 6/20	3	100	807,5	-	290	782,5	782,5	782,5	-	138	-	180	170	25,5	43,5
EV 6/21	3	100	833,5	-	290	808,5	808,5	808,5	-	138	-	180	170	26	44
EV 6/23	3	100	885,5	-	290	-	860,5	860,5	-	138	-	180	170	27	45
EV 6/25	3	100	937,5	-	290	-	912,5	912,5	-	138	-	180	170	28,5	46,5
EV 6/28	4	112	1015,5	-	306	-	990,5	990,5	-	145	-	196	170	30	56,5
EV 6/30	4	112	1067,5	-	306	-	1042,5	1042,5	-	145	-	196	170	31	57,5
EV 6/33	4	112	1145,5	-	306	-	1120,5	1120,5	-	145	-	196	170	32,5	59
EV 6/36	5,5	132	-	-	328	-	1374	-	-	160	-	225	300	53,5	87,1

EV 10

Performance curves 50Hz

MEI ≥ 0,70

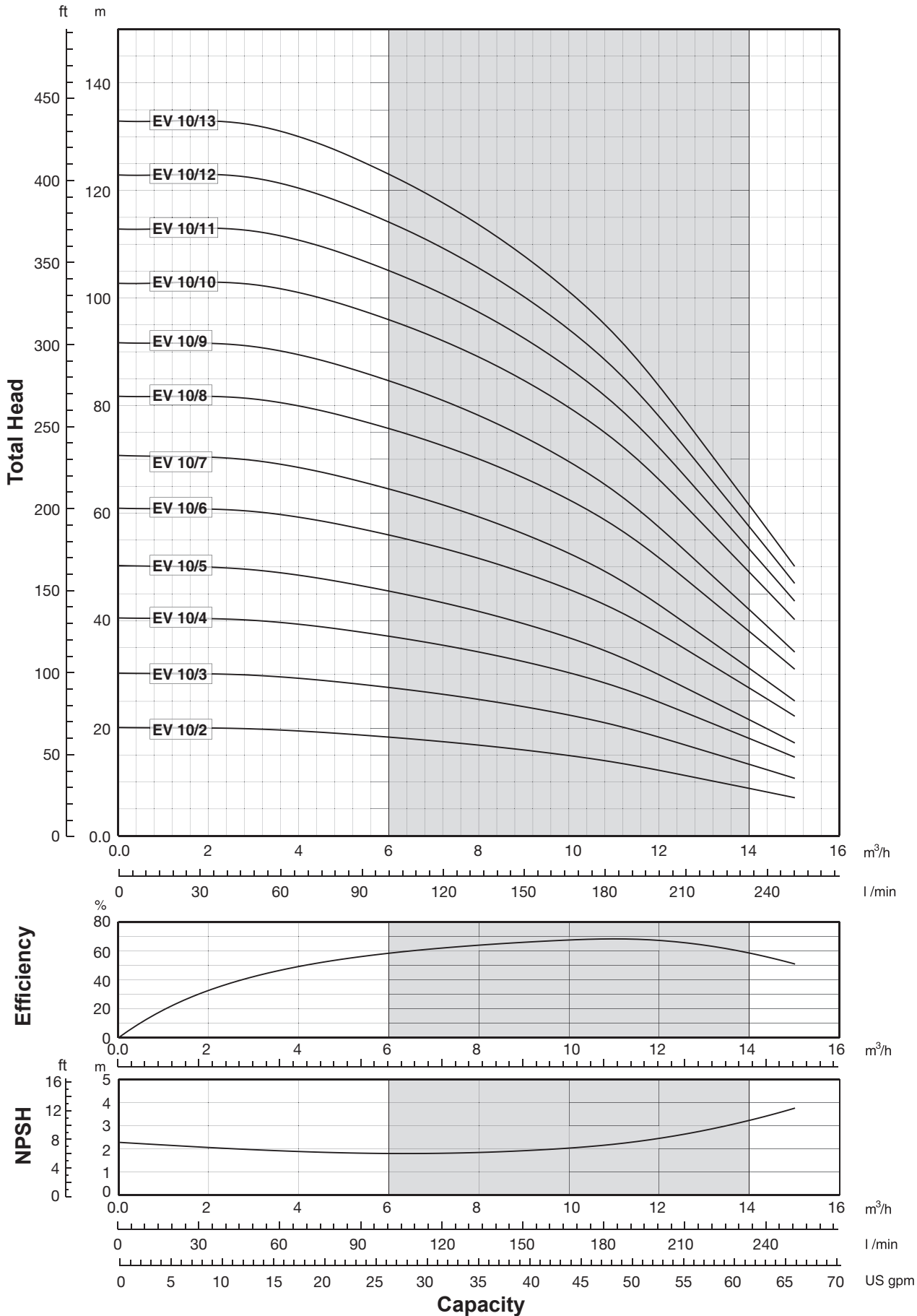

00114122 12/2014

The hydraulic characteristics are guaranteed, according to ISO standard 9906:2012, grade 3B.

It is our policy to continuously develop and improve our products, therefore, we reserve the right to amend specifications without prior notice.

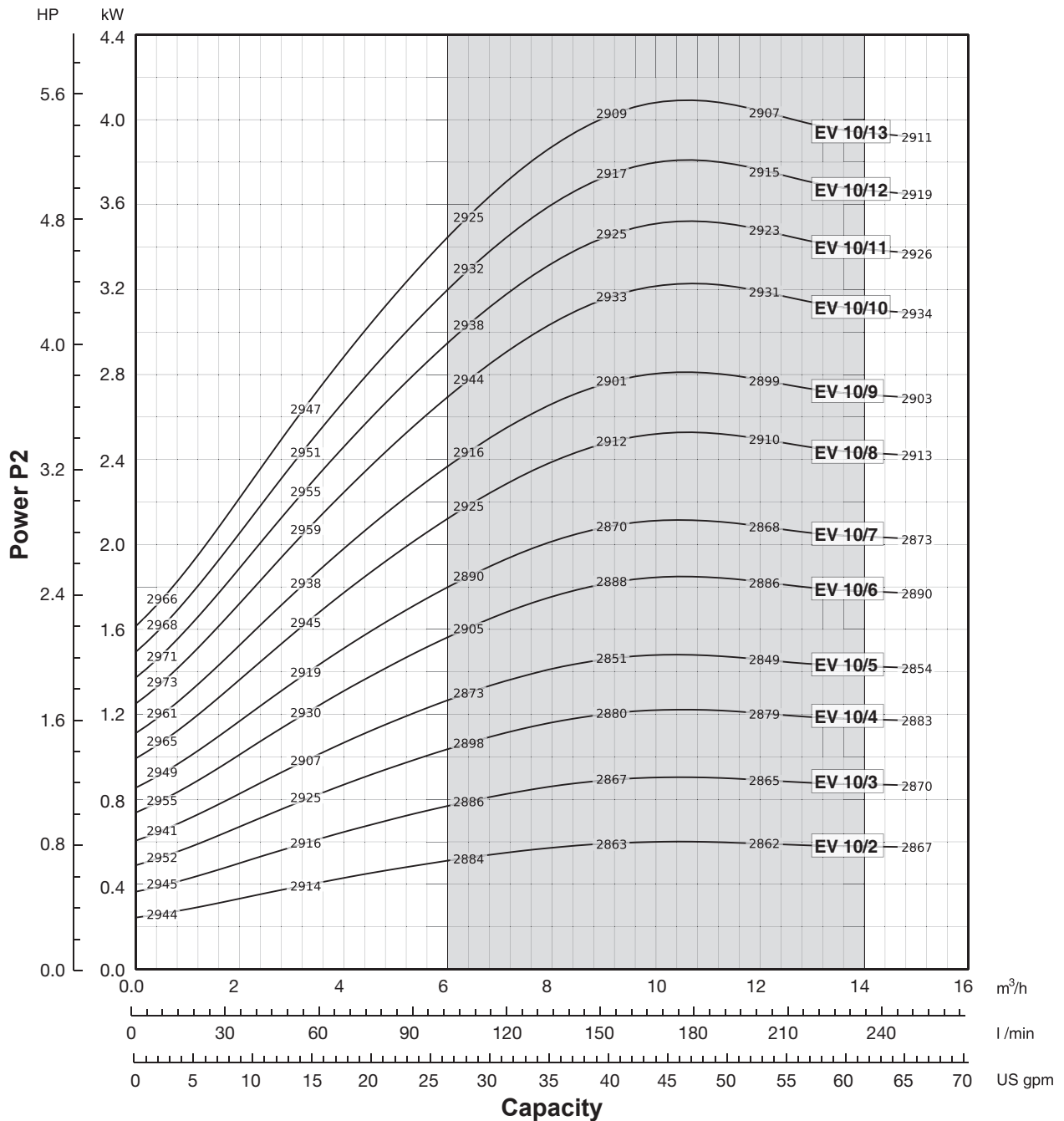

Performance curves of Q, H and P depend on the rpm number according to the following formulae:

$$Q_2 = Q_1 \cdot \left(\frac{n_2}{n_1}\right), \quad H_2 = H_1 \cdot \left(\frac{n_2}{n_1}\right)^2, \quad P_2 = P_1 \cdot \left(\frac{n_2}{n_1}\right)^3, \quad \eta \text{ remains approximately the same.}$$

The rpm number related to the performance curves (Q-H-P) is indicated in the power chart.

Performance curves (Q-H-P) will change in case a motor with rpm number different from indicated values is used.

Q=Capacity, H=Head, P=Power, η =Efficiency

00114122 12/2014

Performance curves 50Hz

MEI ≥ 0,70

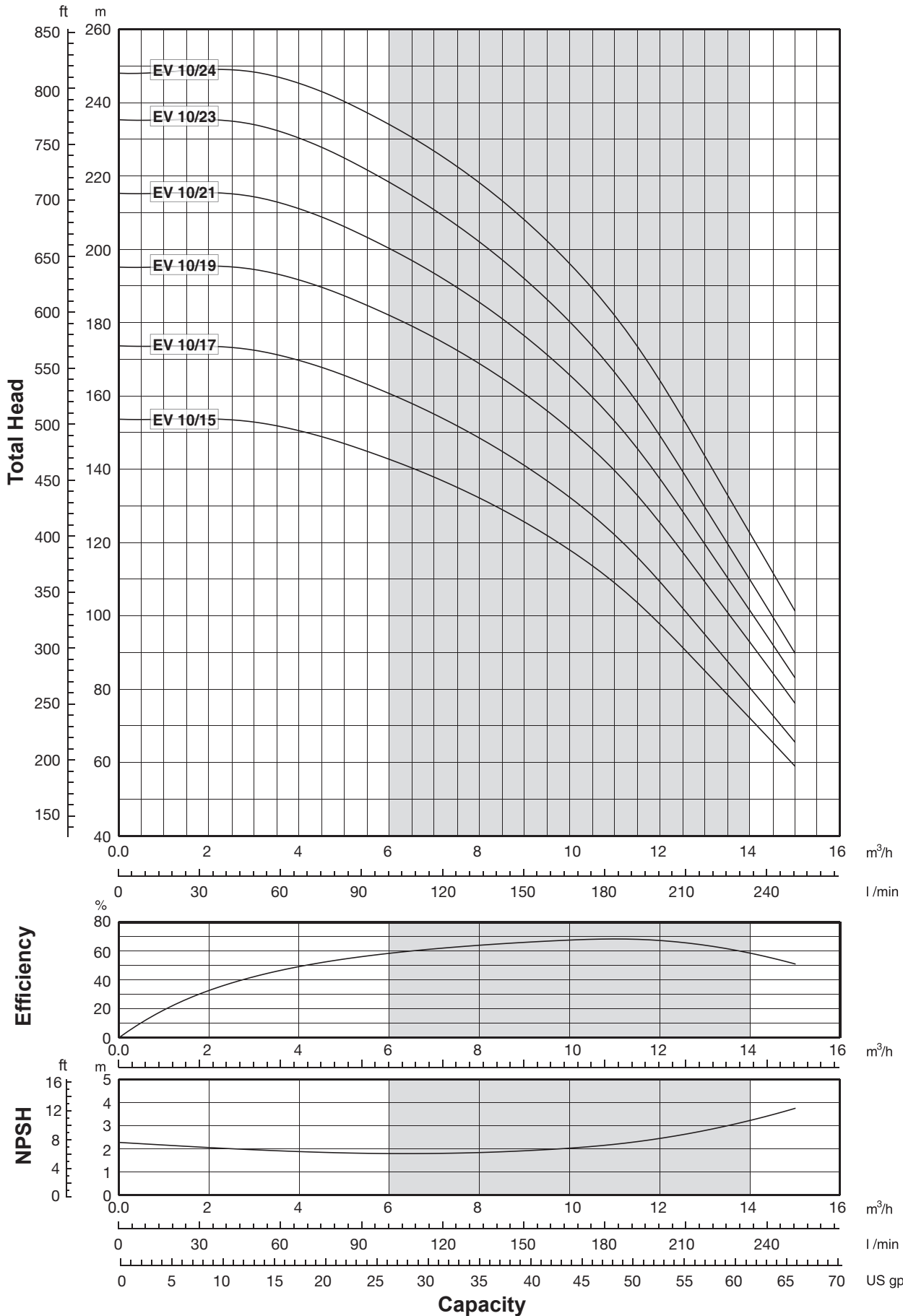

The hydraulic characteristics are guaranteed, according to ISO standard 9906:2012, grade 3B.

It is our policy to continuously develop and improve our products, therefore, we reserve the right to amend specifications without prior notice.

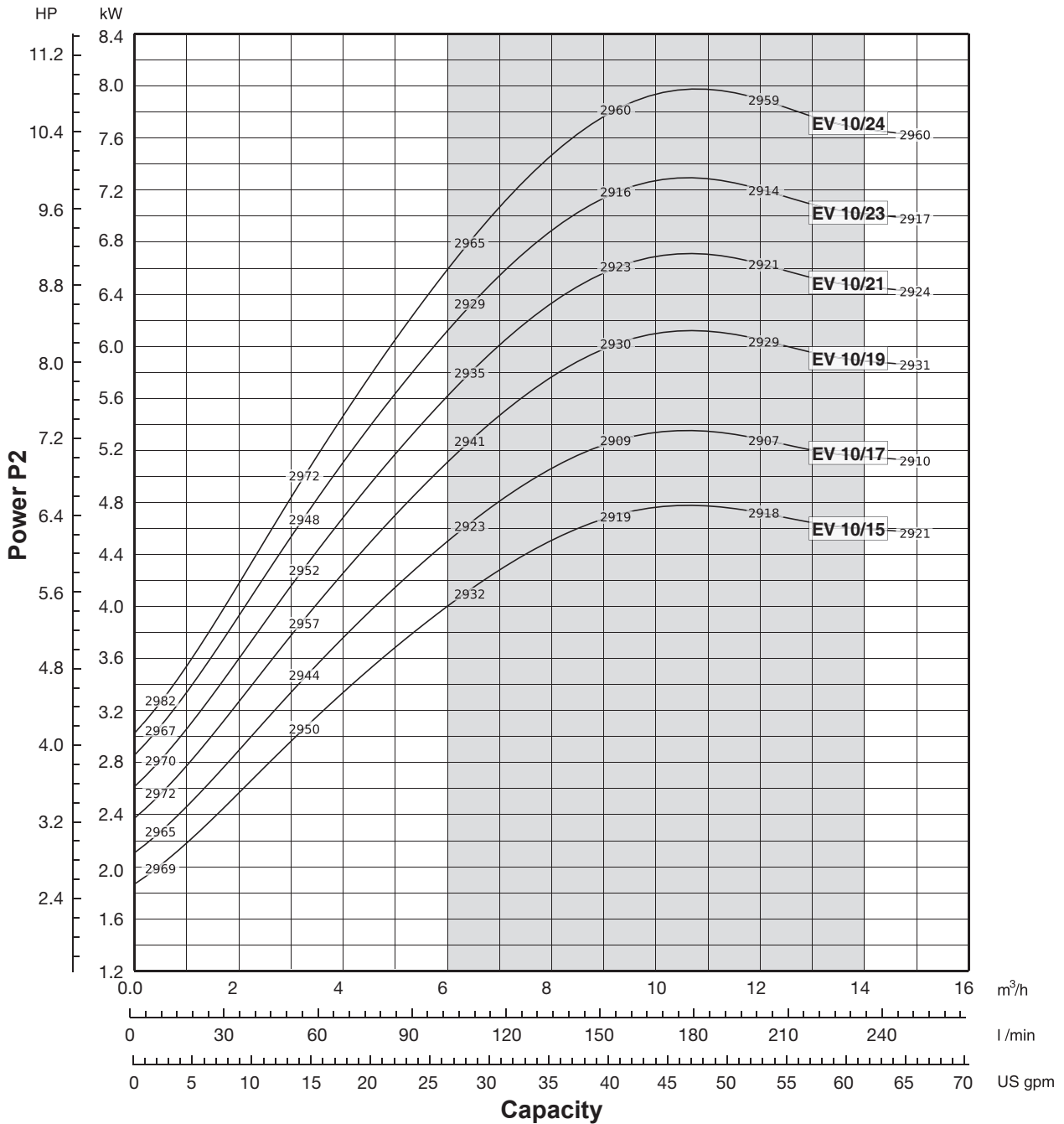

Performance curves of Q, H and P depend on the rpm number according to the following formulae:

$$Q_2 = Q_1 \cdot \left(\frac{n_2}{n_1}\right), \quad H_2 = H_1 \cdot \left(\frac{n_2}{n_1}\right)^2, \quad P_2 = P_1 \cdot \left(\frac{n_2}{n_1}\right)^3, \quad \eta \text{ remains approximately the same.}$$

The rpm number related to the performance curves (Q-H-P) is indicated in the power chart. Performance curves (Q-H-P) will change in case a motor with rpm number different from indicated values is used.

Q=Capacity, H=Head, P=Power, η=Efficiency

00114123 12/2014

Technical data 50Hz

F version

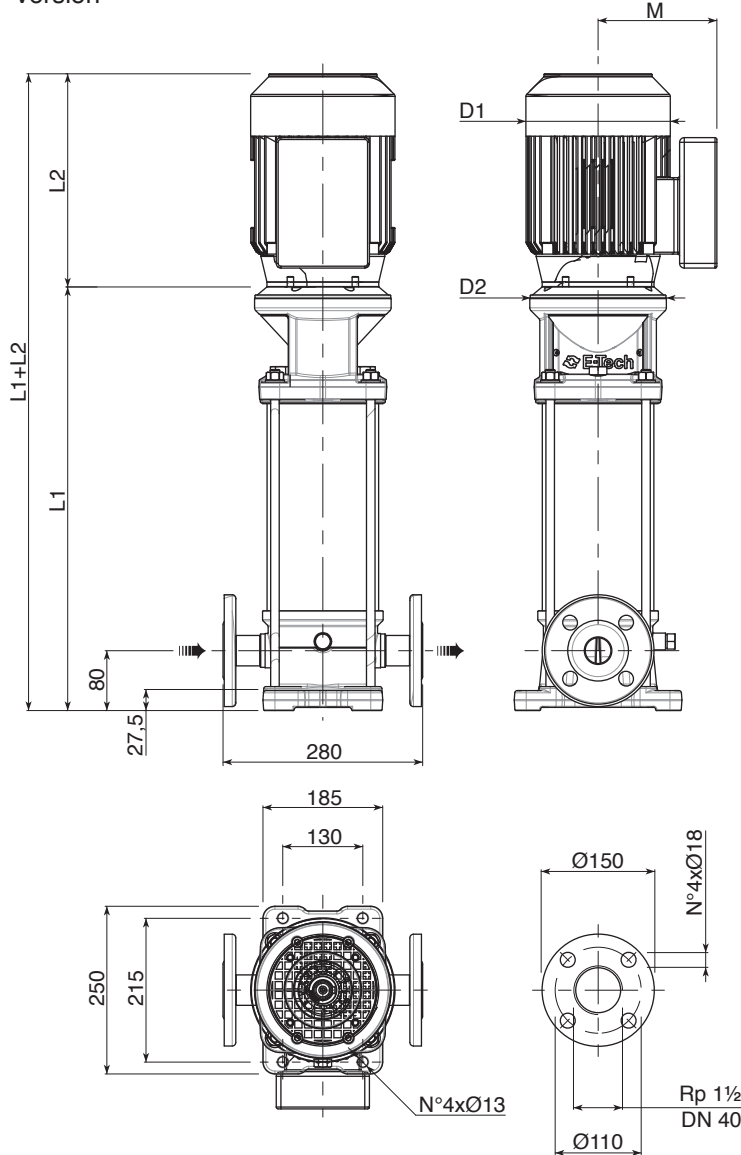

F version Round flanges on body type PN25: the pump is supplied without counterflanges (Optional accessories, including bolts and joints).

T version

Available from EV10/2 to EV10/15

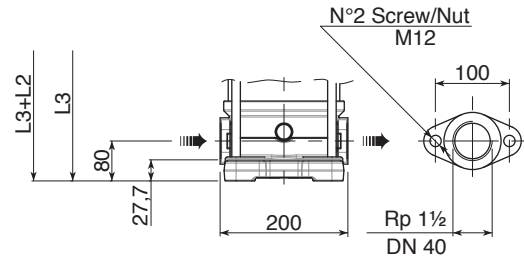

T version Oval flanges on body type PN16: the pump is supplied without threaded oval counter flanges (Optional accessories, including bolts and joints).

V version

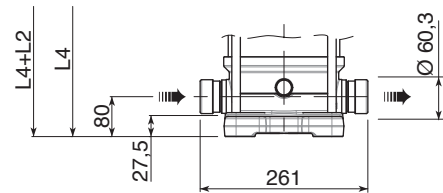

V version Connections with rapid fittings type "Victaulic": the pump is supplied without the collars (Optional accessories).

C version

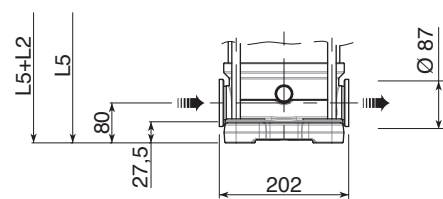

C version Connections with round fittings type Clamp-FlexiClamp: the pump is supplied without collars (Optional accessories).

0011-401.411 02/2015

Pump Model	Motor		Dimensions (mm)									Weight (kg)			
	kW	Dim	L1 F	L2		L3 T	L4 V	L5 C	M		D1		D2	Pump	Electric Pump
				1-PHASE	3-PHASE				1-PHASE	3-PHASE	1-PHASE	3-PHASE			
EV 10/2	0,75	80	347,5	232	232	347,5	347,5	347,5	150	129	160	160	170	17,5	27
EV 10/3	1,1	80	377,5	232	232	377,5	377,5	377,5	150	129	160	160	170	18	29,1
EV 10/4	1,5	90	417,5	267	267	417,5	417,5	417,5	160	138	180	180	170	19,5	33,5
EV 10/5	1,5	90	447,5	267	267	447,5	447,5	447,5	160	138	180	180	170	20	34
EV 10/6	2,2	90	477,5	267	267	477,5	477,5	477,5	160	138	180	180	170	20,5	36,5
EV 10/7	2,2	90	507,5	267	267	507,5	507,5	507,5	160	138	180	180	170	21	37
EV 10/8	3	100	547,5	-	290	547,5	547,5	547,5	-	138	-	180	170	22,5	40,5
EV 10/9	3	100	577,5	-	290	577,5	577,5	577,5	-	138	-	180	170	23	41
EV 10/10	4	112	607,5	-	306	607,5	607,5	607,5	-	145	-	196	170	24	50,5
EV 10/11	4	112	637,5	-	306	637,5	637,5	637,5	-	145	-	196	170	24,5	51
EV 10/12	4	112	667,5	-	306	667,5	667,5	667,5	-	145	-	196	170	25	51,5
EV 10/13	4	112	697,5	-	306	697,5	697,5	697,5	-	145	-	196	170	26	52,5
EV 10/15	5,5	132	933	-	328	933	933	933	-	161	-	225	300	46,5	80,1
EV 10/17	5,5	132	993	-	328	-	993	993	-	161	-	225	300	48	81,6
EV 10/19	7,5	132	1053	-	350	-	1053	1053	-	161	-	225	300	49	85
EV 10/21	7,5	132	1113	-	350	-	1113	1113	-	161	-	225	300	50,5	86,5
EV 10/23	7,5	132	1173	-	350	-	1173	1173	-	161	-	225	300	52	88
EV 10/24	11	160	1223	-	425	-	1223	1223	-	198	-	248	350	55	114

EV 15

Performance curves 50Hz

MEI ≥ 0,70

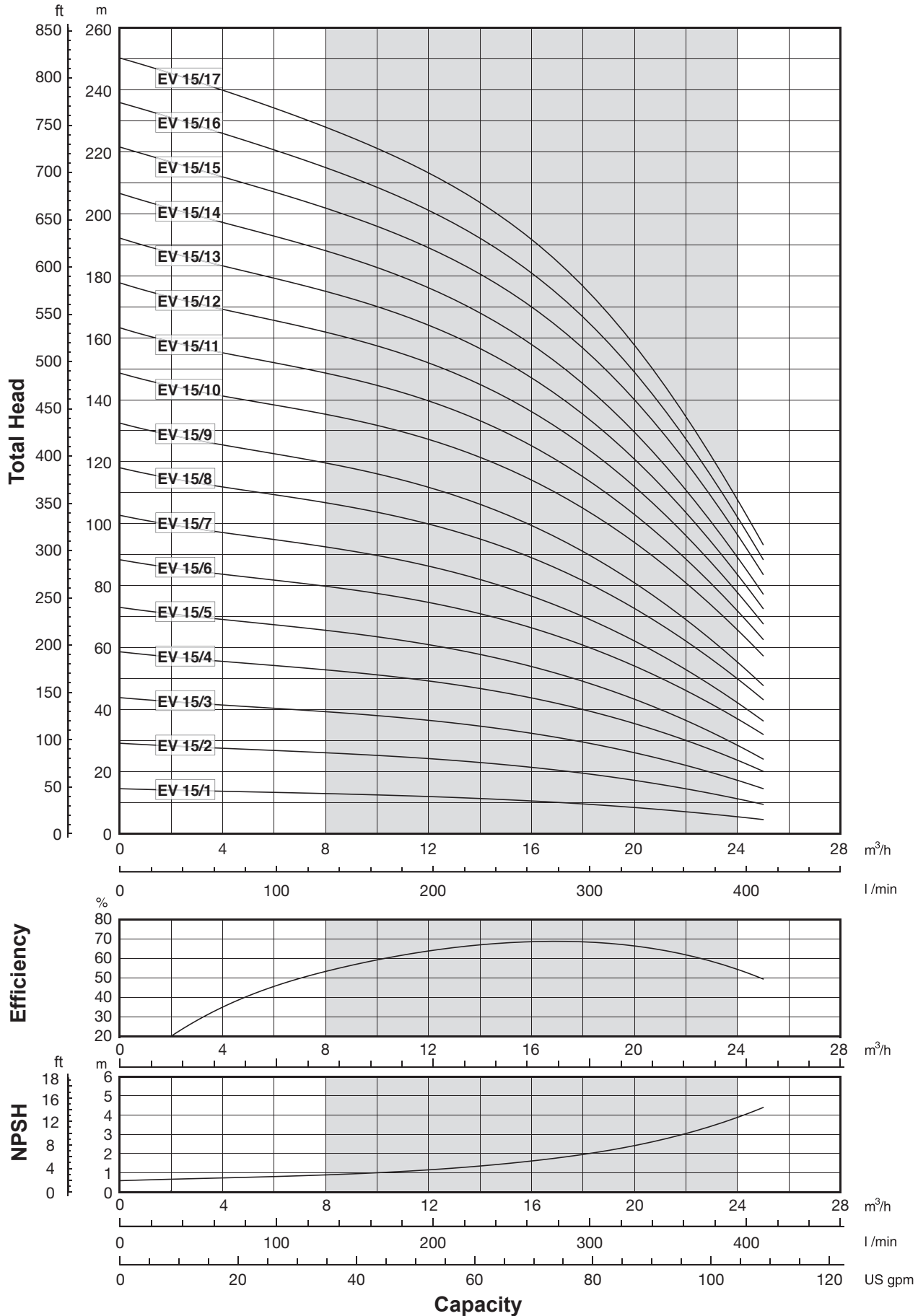

The hydraulic characteristics are guaranteed, according to ISO standard 9906:2012, grade 3B.

It is our policy to continuously develop and improve our products, therefore, we reserve the right to amend specifications without prior notice.

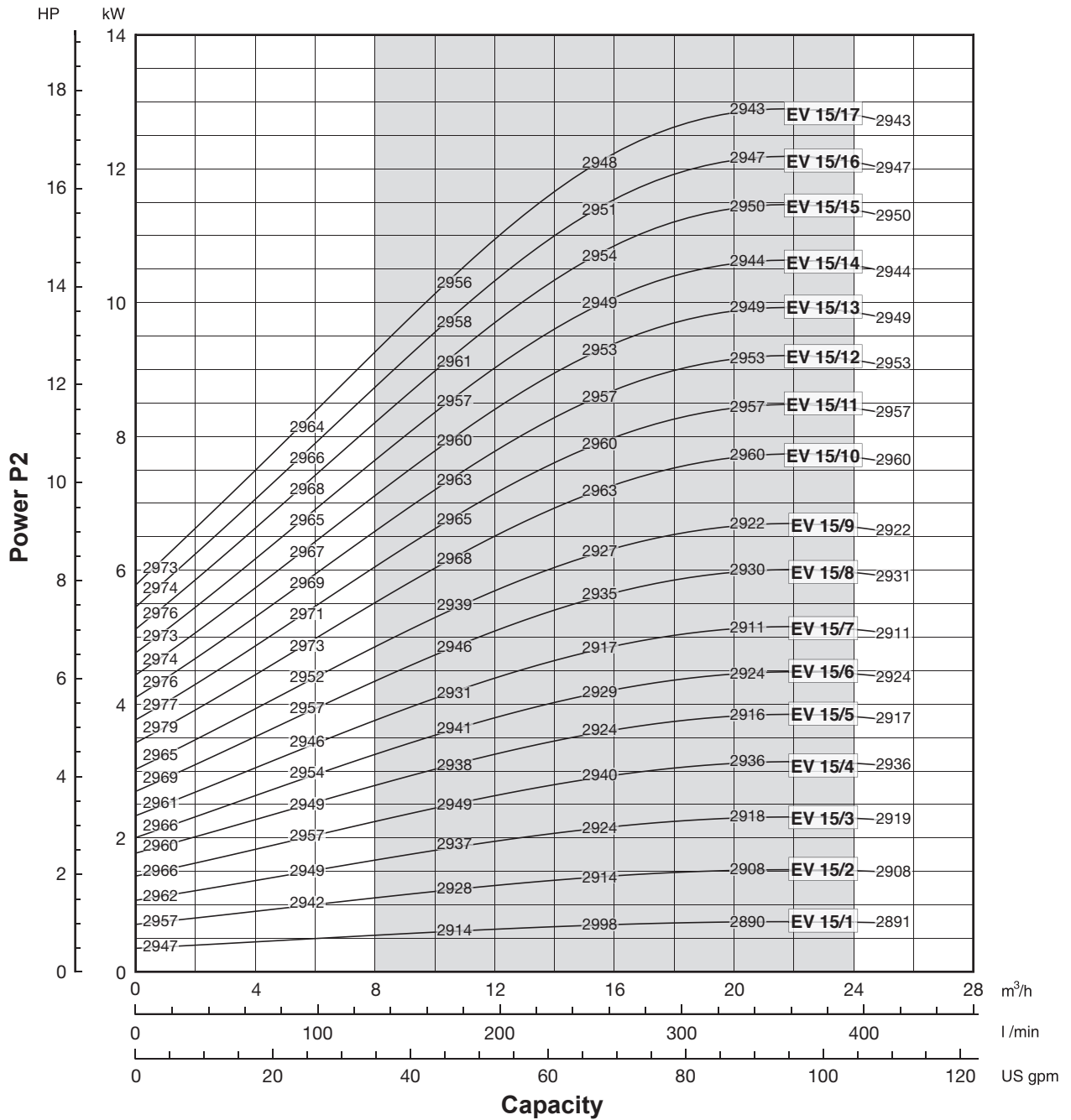

Performance curves of Q, H and P depend on the rpm number according to the following formulae:

$$Q_2 = Q_1 \cdot \left(\frac{n_2}{n_1}\right), \quad H_2 = H_1 \cdot \left(\frac{n_2}{n_1}\right)^2, \quad P_2 = P_1 \cdot \left(\frac{n_2}{n_1}\right)^3, \quad \eta \text{ remains approximately the same.}$$

The rpm number related to the performance curves (Q-H-P) is indicated in the power chart.

Performance curves (Q-H-P) will change in case a motor with rpm number different from indicated values is used.

Q=Capacity, H=Head, P=Power, η=Efficiency

Technical data 50Hz

F version

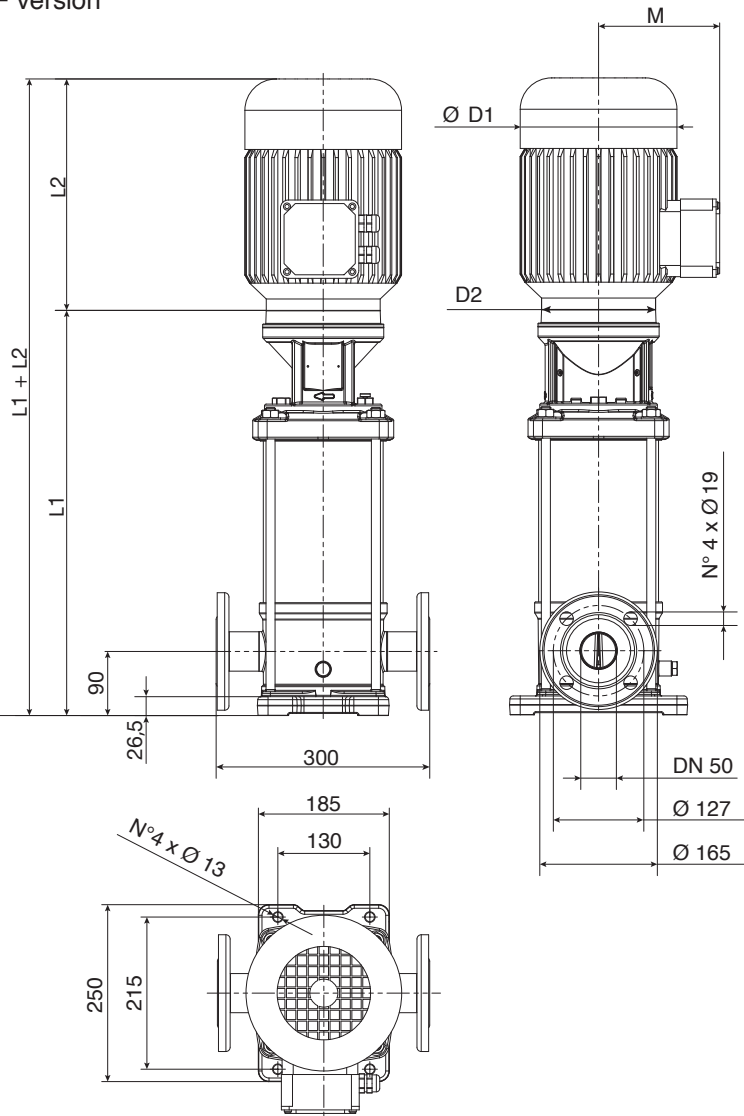

F version Round flanges on body type PN25: the pump is supplied without counterflanges (Optional accessories, including bolts and joints).

T version

Available from EV15/1 to EV15/10

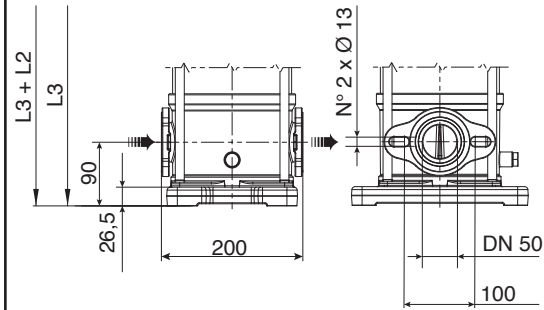

T version Oval flanges on body type PN16: the pump is supplied without threaded oval counter flanges (Optional accessories, including bolts and joints).

V version

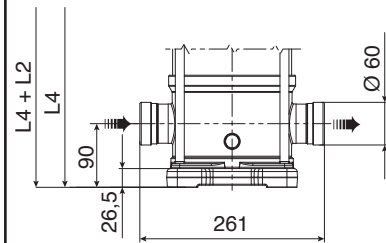

V version Connections with rapid fittings type "Victaulic": the pump is supplied without the collars (Optional accessories).

C version

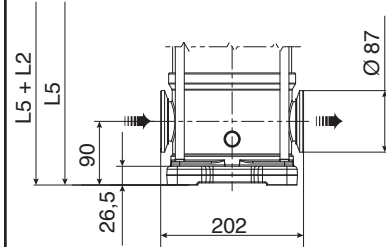

C version Connections with round fittings type Clamp-FlexiClamp: the pump is supplied without collars (Optional accessories).

00114095 05/2014

Pump Model	Motor		Dimensions (mm)										Weight (kg)		
	kW	Dim	L1 F	L2 1-PHASE	L2 3-PHASE	L3 T	L4 V	L5 C	M 1-PHASE	M 3-PHASE	D1 1-PHASE	D1 3-PHASE	D2	Pump	Electric Pump
EV 15/1	1,1	80	405	232	232	405	405	405	150	129	160	160	170	23,5	35,5
EV 15/2	2,2	90	415	267	267	415	415	415	160	138	180	180	170	25	41
EV 15/3	3	100	473	-	267	473	473	473	-	138	-	180	170	27	45,7
EV 15/4	4	112	521	-	306	521	521	521	-	145	-	196	170	28,5	51,3
EV 15/5	4	112	569	-	306	569	569	569	-	145	-	196	170	30	52,8
EV 15/6	5,5	132	804	-	328	804	804	804	-	161	-	225	300	52	86
EV 15/7	5,5	132	852	-	328	852	852	852	-	161	-	225	300	53	87
EV 15/8	7,5	132	900	-	350	900	900	900	-	161	-	225	300	54,5	90,5
EV 15/9	7,5	132	948	-	350	948	948	948	-	161	-	225	300	56	92
EV 15/10	11	160	1016	-	425	1016	1016	1016	-	198	-	248	350	60	118
EV 15/11	11	160	1064	-	425	-	1064	1064	-	198	-	248	350	61,5	119,5
EV 15/12	11	160	1112	-	425	-	1112	1112	-	198	-	248	350	63	121
EV 15/13	11	160	1160	-	425	-	1160	1160	-	198	-	248	350	64,5	122,5
EV 15/14	11	160	1208	-	425	-	1208	1208	-	198	-	248	350	66	124
EV 15/15	15	160	1256	-	476	-	1256	1256	-	198	-	248	350	67	131
EV 15/16	15	160	1304	-	476	-	1304	1304	-	198	-	248	350	68,5	132,5
EV 15/17	15	160	1352	-	476	-	1352	1352	-	198	-	248	350	70	134

EV 20

Performance curves 50Hz

MEI ≥ 0,70

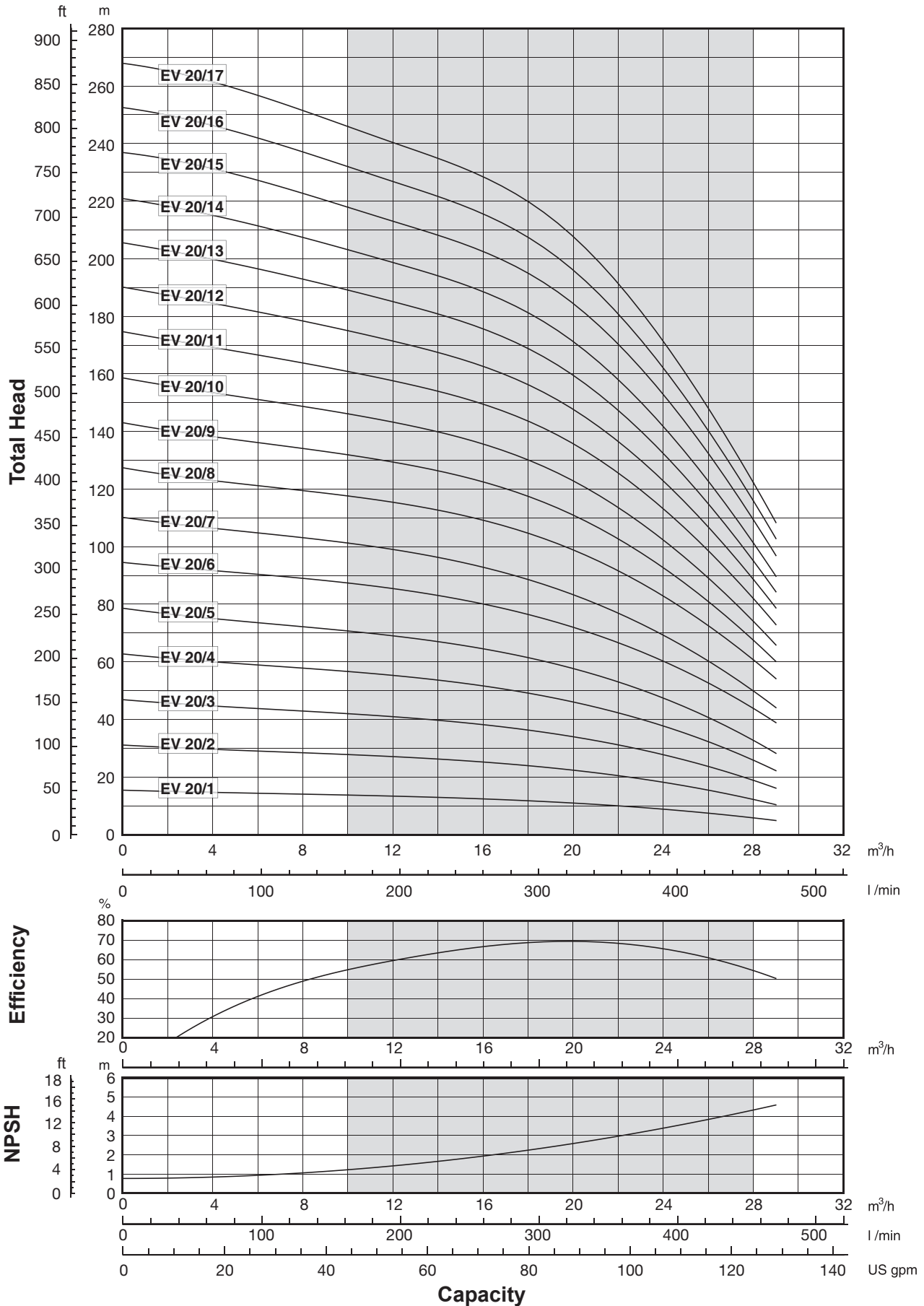

00110091 11/2013

The hydraulic characteristics are guaranteed, according to ISO standard 9906:2012, grade 3B.

It is our policy to continuously develop and improve our products, therefore, we reserve the right to amend specifications without prior notice.



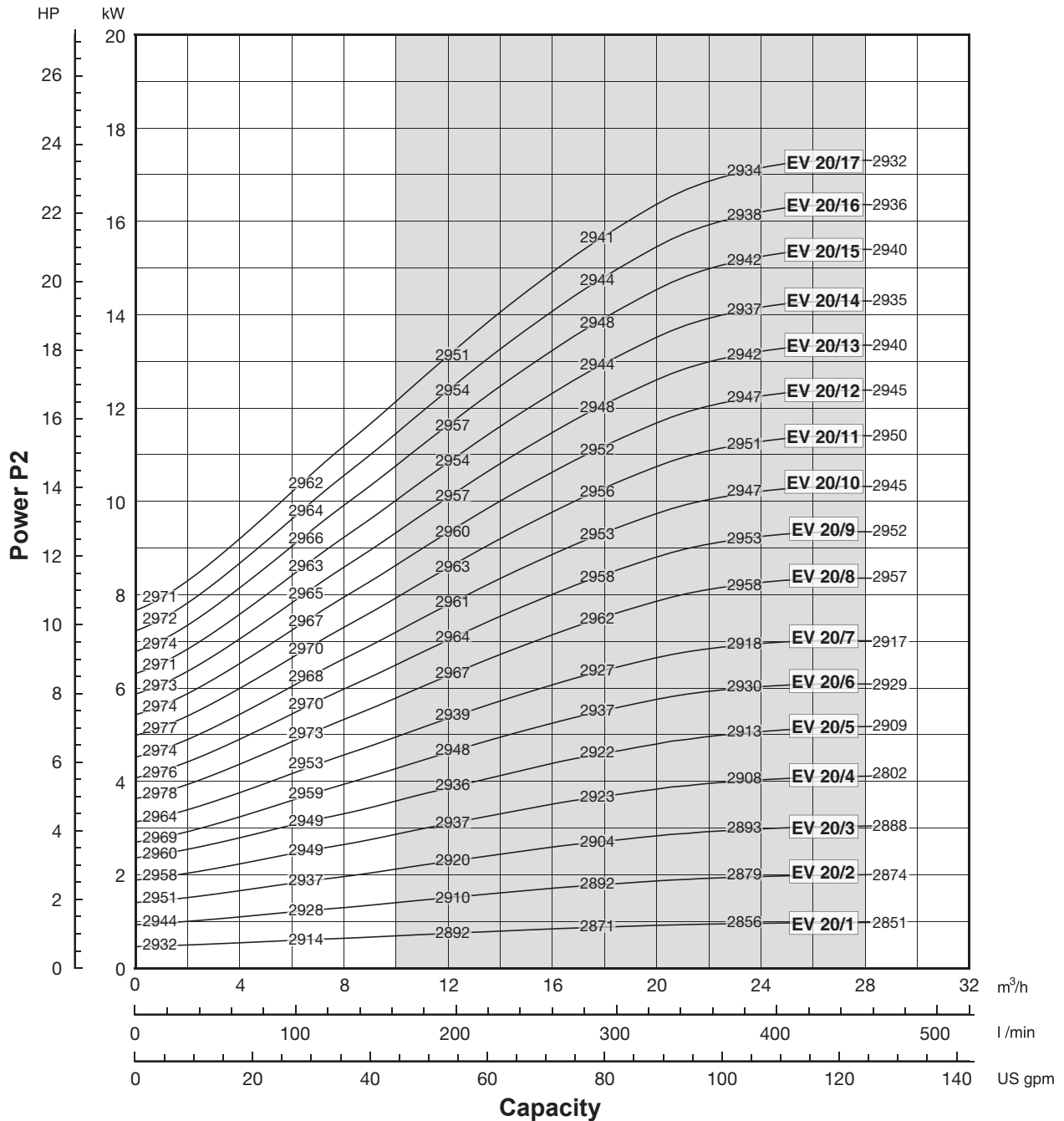

Performance curves of Q, H and P depend on the rpm number according to the following formulae:

$$Q_2 = Q_1 \cdot \left(\frac{n_2}{n_1}\right), \quad H_2 = H_1 \cdot \left(\frac{n_2}{n_1}\right)^2, \quad P_2 = P_1 \cdot \left(\frac{n_2}{n_1}\right)^3, \quad \eta \text{ remains approximately the same.}$$

The rpm number related to the performance curves (Q-H-P) is indicated in the power chart. Performance curves (Q-H-P) will change in case a motor with rpm number different from indicated values is used.

Q=Capacity, H=Head, P=Power, η=Efficiency

Technical data 50Hz

F version

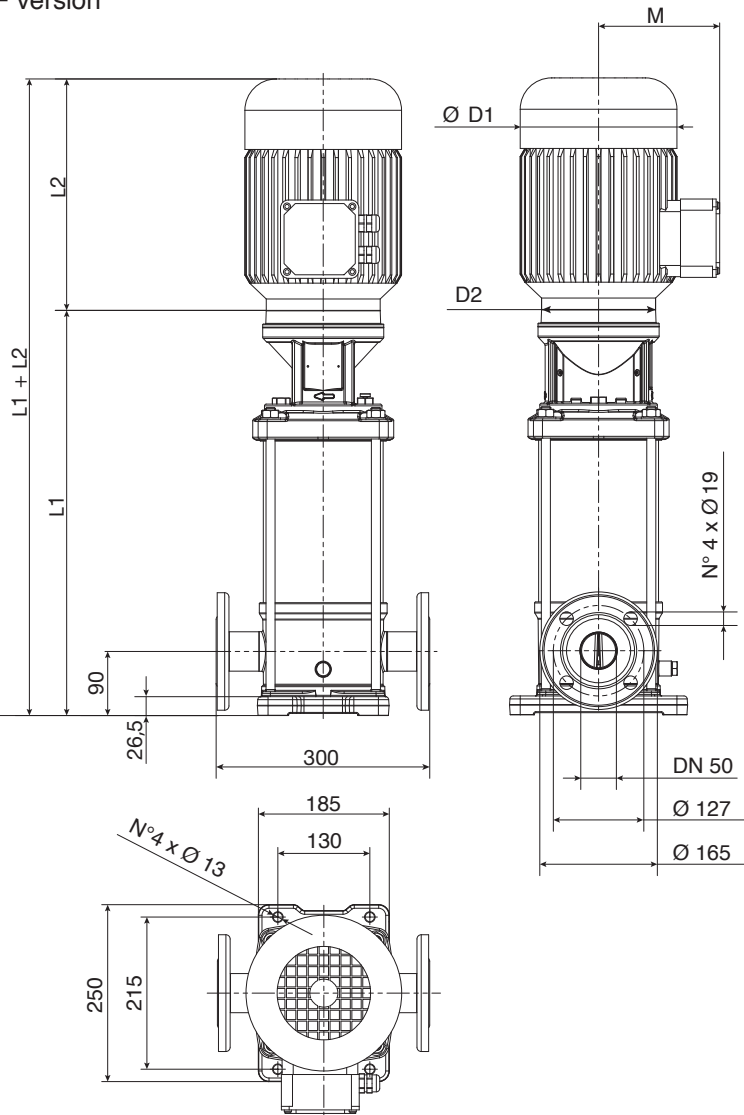

F version Round flanges on body type PN25: the pump is supplied without counterflanges (Optional accessories, including bolts and joints).

T version

Available from EV20/1 to EV20/10

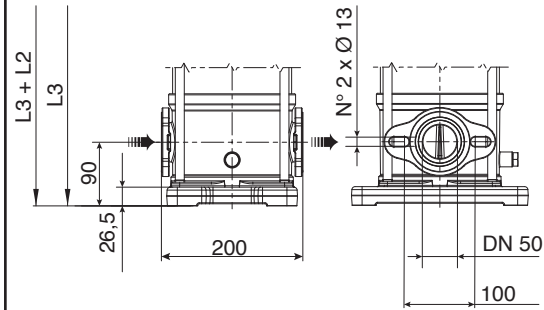

T version Oval flanges on body type PN16: the pump is supplied without threaded oval counter flanges (Optional accessories, including bolts and joints).

V version

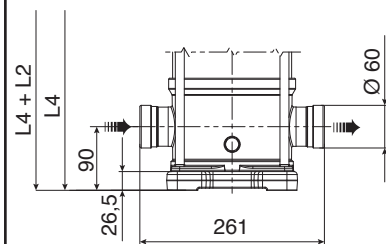

V version Connections with rapid fittings type "Victaulic": the pump is supplied without the collars (Optional accessories).

C version

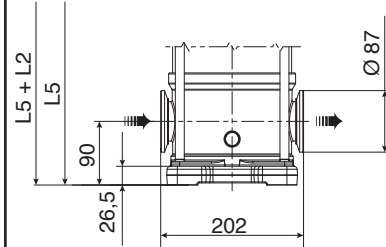

C version Connections with round fittings type Clamp-FlexiClamp: the pump is supplied without collars (Optional accessories).

00114095 05/2014

Pump Model	Motor		Dimensions (mm)										Weight (kg)		
	kW	Dim	L1 F	L2 1-PHASE	L2 3-PHASE	L3 T	L4 V	L5 C	M 1-PHASE	M 3-PHASE	D1 1-PHASE	D1 3-PHASE	D2	Pump	Electric Pump
EV 20/1	1,1	80	405	232	232	405	405	405	150	129	160	160	170	23,5	35,5
EV 20/2	2,2	90	415	267	267	415	415	415	160	138	180	180	170	25,5	41,5
EV 20/3	4	112	473	-	306	473	473	473	-	145	-	196	170	27	49,8
EV 20/4	5,5	132	708	-	328	708	708	708	-	161	-	225	300	49	83
EV 20/5	5,5	132	756	-	328	756	756	756	-	161	-	225	300	50,5	84,5
EV 20/6	7,5	132	804	-	350	804	804	804	-	161	-	225	300	52	88
EV 20/7	7,5	132	852	-	350	852	852	852	-	161	-	225	300	53	89
EV 20/8	11	160	920	-	425	920	920	920	-	198	-	248	350	57,5	115,5
EV 20/9	11	160	968	-	425	968	968	968	-	198	-	248	350	59	117
EV 20/10	11	160	1016	-	425	1016	1016	1016	-	198	-	248	350	60,5	118,5
EV 20/11	15	160	1064	-	476	-	1064	1064	-	198	-	248	350	61,5	125,5
EV 20/12	15	160	1112	-	476	-	1112	1112	-	198	-	248	350	63	127
EV 20/13	15	160	1160	-	476	-	1160	1160	-	198	-	248	350	64,5	128,5
EV 20/14	15	160	1208	-	476	-	1208	1208	-	198	-	248	350	66	130
EV 20/15	18,5	160	1256	-	542	-	1256	1256	-	235	-	317	350	67,5	156,4
EV 20/16	18,5	160	1304	-	542	-	1304	1304	-	235	-	317	350	68,5	157,4
EV 20/17	18,5	160	1352	-	542	-	1352	1352	-	235	-	317	350	70	158,9

EV 30

Performance curves 50Hz

MEI ≥ 0,70

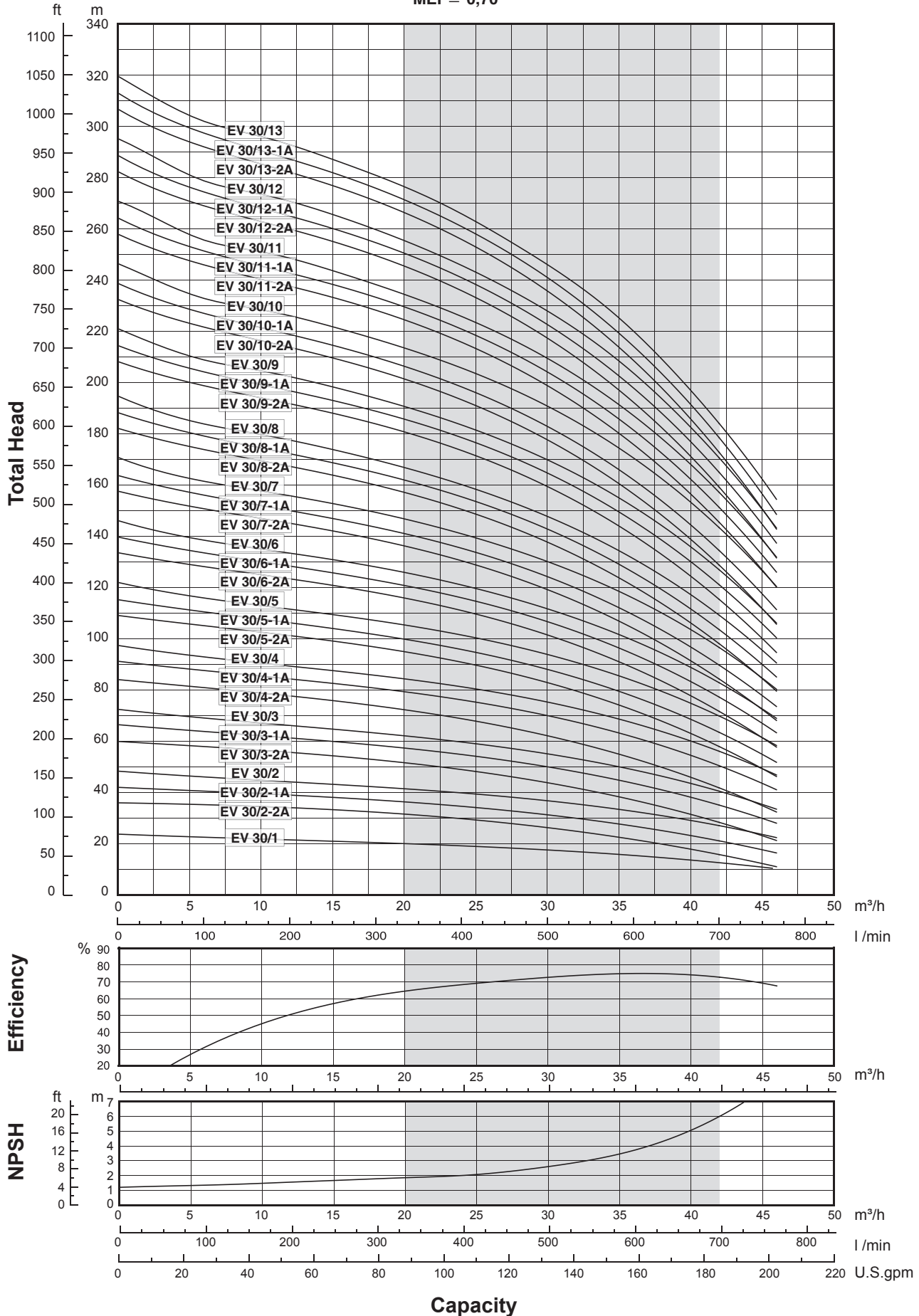

00110080 11/2013

The hydraulic characteristics are guaranteed, according to ISO standard 9906:2012, grade 3B.

It is our policy to continuously develop and improve our products, therefore, we reserve the right to amend specifications without prior notice.



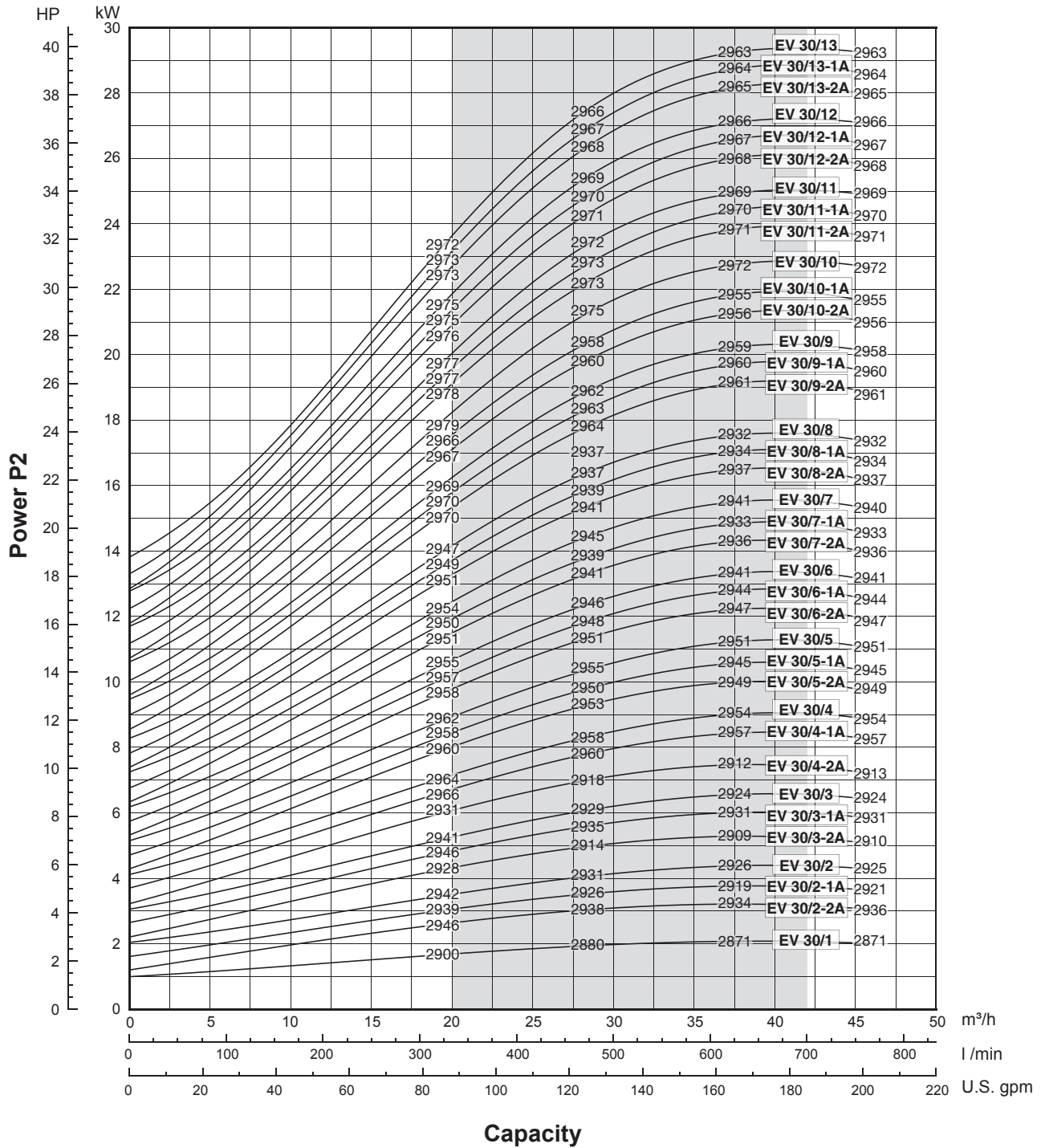

Performance curves of Q, H and P depend on the rpm number according to the following formulae:

$$Q_2 = Q_1 \cdot \left(\frac{n_2}{n_1}\right), \quad H_2 = H_1 \cdot \left(\frac{n_2}{n_1}\right)^2, \quad P_2 = P_1 \cdot \left(\frac{n_2}{n_1}\right)^3, \quad \eta \text{ remains approximately the same.}$$

The rpm number related to the performance curves (Q-H-P) is indicated in the power chart.
Performance curves (Q-H-P) will change in case a motor with rpm number different from indicated values is used.

Q=Capacity, H=Head, P=Power, η =Efficiency

00110080 11/2013

Technical data 50Hz

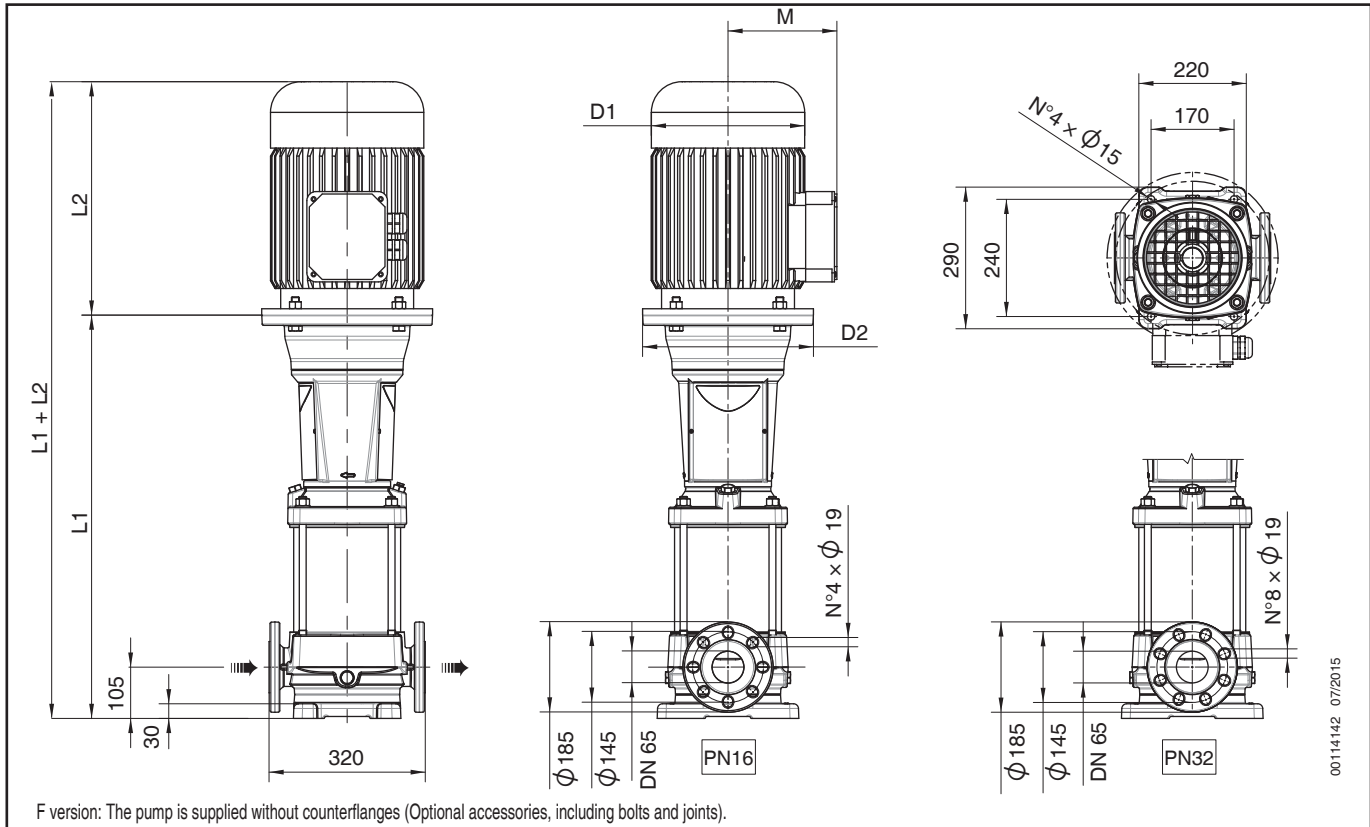

Pump Model	Motor		Dimensions (mm)						Weight (kg)		
	kW	Dim.	L1	L2	M	D1	D2	L1 + L2	Pump	Motor	Electric Pump
EV 30/1	2,2	90	445	267	138	180	170	712	53	16	69
EV 30/2-2A	4	112	537	306	145	196	170	843	57	22,8	80
EV 30/2-1A	4	112	724	306	145	196	170	1030	74,5	22,8	97,5
EV 30/2	5,5	132	724	328	161	225	300	1052	74,5	34	108,5
EV 30/3-2A	5,5	132	806	328	161	225	300	1134	78,5	34	112,5
EV 30/3-1A	7,5	132	806	350	161	225	300	1156	78,5	36	114,5
EV 30/3	7,5	132	806	350	161	225	300	1238	78,5	36	114,5
EV 30/4-2A	7,5	132	888	350	161	225	300	1333	85,5	36	121,5
EV 30/4-1A	11	160	908	425	198	248	350	1333	85,5	58	143,5
EV 30/4	11	160	908	425	198	248	350	1415	85,5	58	143,5
EV 30/5-2A	11	160	990	425	198	248	350	1415	89,5	58	147,5
EV 30/5-1A	11	160	990	425	198	248	350	1415	89,5	58	147,5
EV 30/5	15	160	990	476	198	248	350	1548	89,5	64	153,5
EV 30/6-2A	15	160	1072	476	198	248	350	1548	93,5	64	157,5
EV 30/6-1A	15	160	1072	476	198	248	350	1548	93,5	64	157,5
EV 30/6	15	160	1072	476	198	248	350	1630	93,5	64	157,5
EV 30/7-2A	15	160	1154	476	198	248	350	1652	97,5	64	161,5
EV 30/7-1A	15	160	1154	476	198	248	350	1630	97,5	64	161,5
EV 30/7	18,5	160	1154	542	238	317	350	1696	97,5	89	186,5
EV 30/8-2A	18,5	160	1236	542	238	317	350	1778	101,5	89	190,5
EV 30/8-1A	18,5	160	1236	542	238	317	350	1778	101,5	89	190,5
EV 30/8	18,5	160	1236	542	238	317	350	1778	101,5	89	190,5
EV 30/9-2A	22	180	1318	542	238	360	350	1860	105,5	108,7	214
EV 30/9-1A	22	180	1318	542	238	360	350	1860	105,5	108,7	214
EV 30/9	22	180	1318	542	238	360	350	1860	105,5	108,7	214
EV 30/10-2A	22	180	1400	542	238	360	350	1942	112,5	108,7	221
EV 30/10-1A	22	180	1400	542	238	360	350	1942	112,5	108,7	221
EV 30/10	30	200	1405	658	297	399	400	2063	112,5	228	340,5
EV 30/11-2A	30	200	1487	658	297	399	400	2145	116,5	228	344,5
EV 30/11-1A	30	200	1487	658	297	399	400	2145	116,5	228	344,5
EV 30/11	30	200	1487	658	297	399	400	2145	116,5	228	344,5
EV 30/12-2A	30	200	1569	658	297	399	400	2227	120,5	228	348,5
EV 30/12-1A	30	200	1569	658	297	399	400	2227	120,5	228	348,5
EV 30/12	30	200	1569	658	297	399	400	2227	120,5	228	348,5
EV 30/13-2A	30	200	1651	658	297	399	400	2309	124,5	228	352,5
EV 30/13-1A	30	200	1651	658	297	399	400	2309	124,5	228	352,5
EV 30/13	30	200	1651	658	297	399	400	2309	124,5	228	352,5

EV 45

EV 45

EU

Performance curves 50Hz

MEI ≥ 0,70

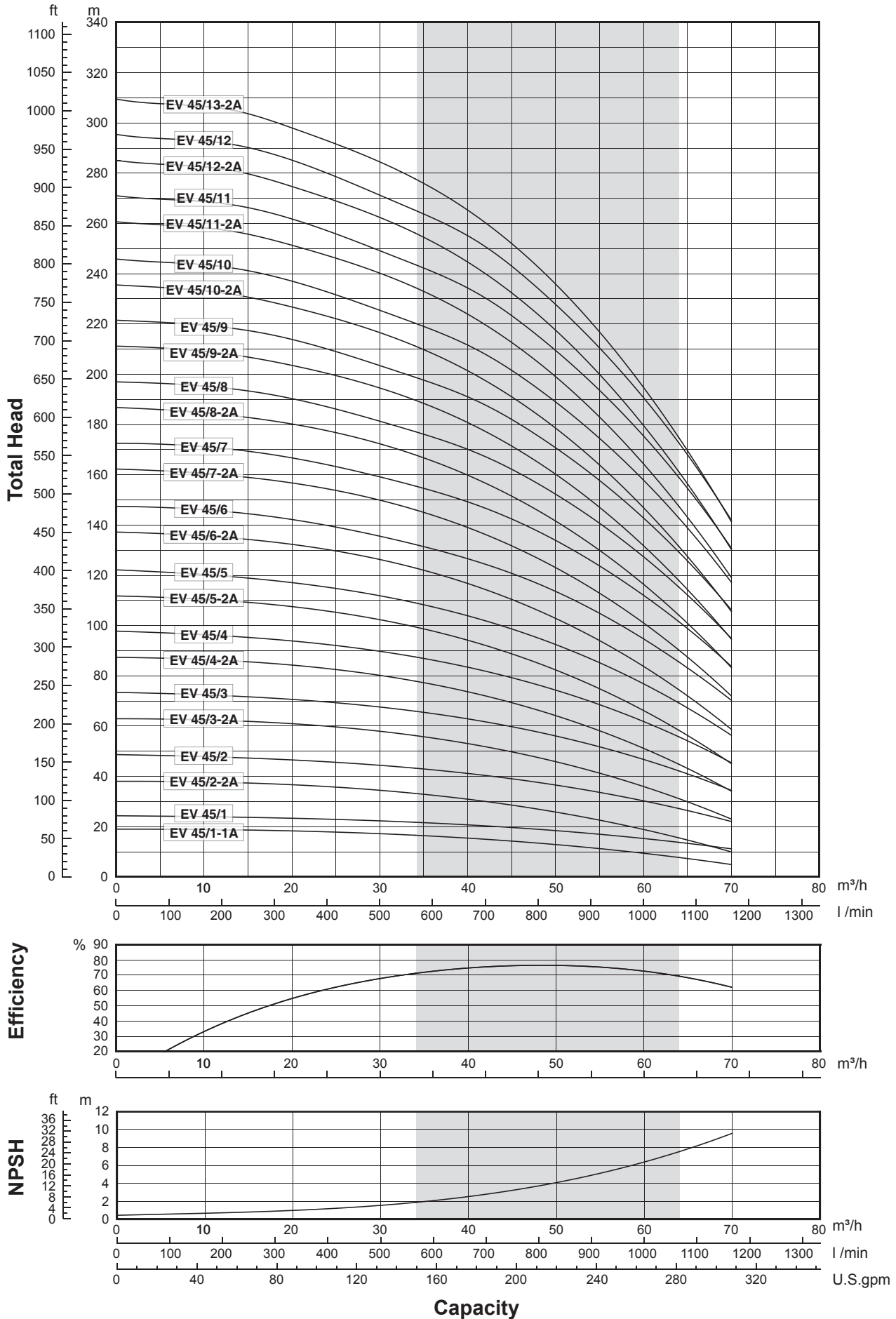

00110081 11/2013

The hydraulic characteristics are guaranteed, according to ISO standard 9906:2012, grade 3B.



It is our policy to continuously develop and improve our products, therefore, we reserve the right to amend specifications without prior notice.

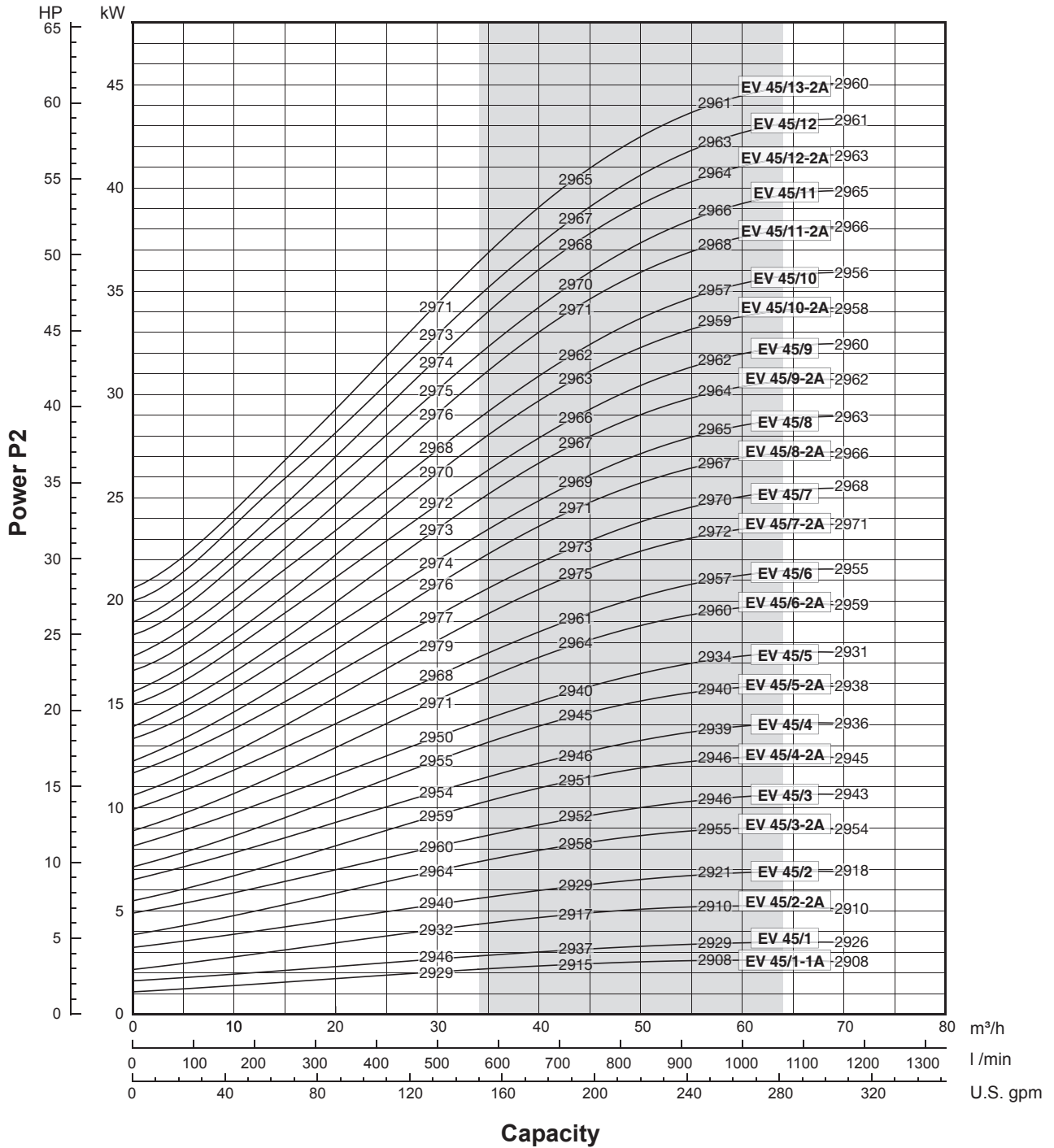

Performance curves of Q, H and P depend on the rpm number according to the following formulae:

$$Q_2 = Q_1 \cdot \left(\frac{n_2}{n_1}\right), \quad H_2 = H_1 \cdot \left(\frac{n_2}{n_1}\right)^2, \quad P_2 = P_1 \cdot \left(\frac{n_2}{n_1}\right)^3, \quad \eta \text{ remains approximately the same.}$$

The rpm number related to the performance curves (Q-H-P) is indicated in the power chart.

Performance curves (Q-H-P) will change in case a motor with rpm number different from indicated values is used.

Q=Capacity, H=Head, P=Power, η=Efficiency

Technical data 50Hz

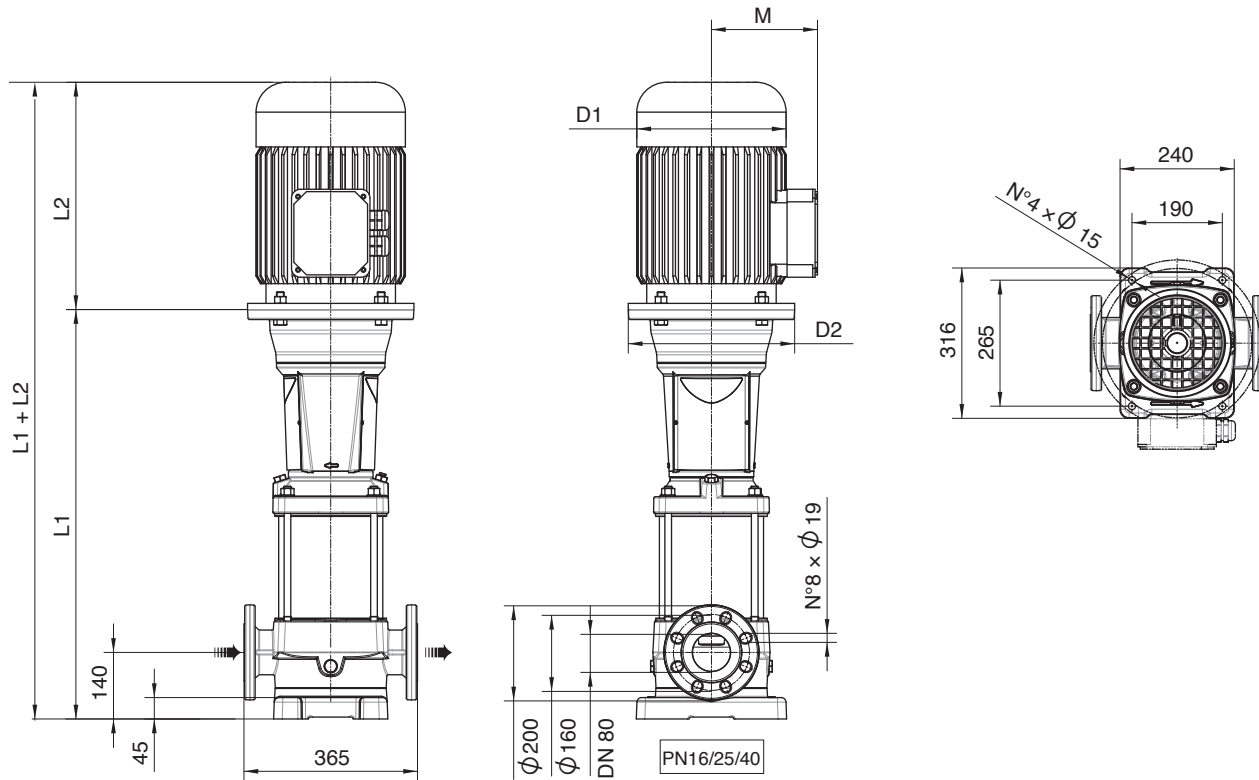

00104082_04/2013

F version: The pump is supplied without counterflanges (Optional accessories, including bolts and joints).

Pump Model	Motor		Dimensions (mm)						Weight (kg)		
	kW	Dim.	L1	L2	M	D1	D2	L1 + L2	Pump	Motor	Electric Pump
EV 45/1-1A	3	100	490	267	138	180	170	757	59	18,7	78
EV 45/1	4	112	490	306	145	196	170	796	59	22,8	82
EV 45/2-2A	5,5	132	759	328	161	225	300	1087	80,5	34	114,5
EV 45/2	7,5	132	759	350	161	225	300	1109	80,5	36	116,5
EV 45/3-2A	11	160	861	425	198	248	350	1286	87,5	58	145,5
EV 45/3	11	160	861	425	198	248	350	1286	87,5	58	145,5
EV 45/4-2A	15	160	943	476	198	248	350	1419	91,5	64	155,5
EV 45/4	15	160	943	476	198	248	350	1419	91,5	64	155,5
EV 45/5-2A	18,5	160	1025	542	238	317	350	1567	95,5	89	184,5
EV 45/5	18,5	160	1025	542	238	317	350	1567	95,5	89	184,5
EV 45/6-2A	22	180	1107	542	238	317	350	1649	99	108,5	208
EV 45/6	22	180	1107	542	238	317	350	1649	99	108,5	208
EV 45/7-2A	30	200	1194	658	297	399	400	1852	106	228	334
EV 45/7	30	200	1194	658	297	399	400	1852	106	228	334
EV 45/8-2A	30	200	1276	658	297	399	400	1934	110	228	338
EV 45/8	30	200	1276	658	297	399	400	1934	110	228	338
EV 45/9-2A	37	200	1358	658	297	399	400	2016	114	242	356
EV 45/9	37	200	1358	658	297	399	400	2016	114	242	356
EV 45/10-2A	37	200	1440	658	297	399	400	2098	118	242	360
EV 45/10	37	200	1440	658	297	399	400	2098	118	242	360
EV 45/11-2A	45	225	1522	699	333	465	450	2221	125	308	433
EV 45/11	45	225	1522	699	333	465	450	2221	125	308	433
EV 45/12-2A	45	225	1604	699	333	465	450	2303	129	308	437
EV 45/12	45	225	1604	699	333	465	450	2303	129	308	437
EV 45/13-2A	45	225	1686	699	333	465	450	2385	133	308	441

EV 65

Performance curves 50Hz

MEI ≥ 0,70

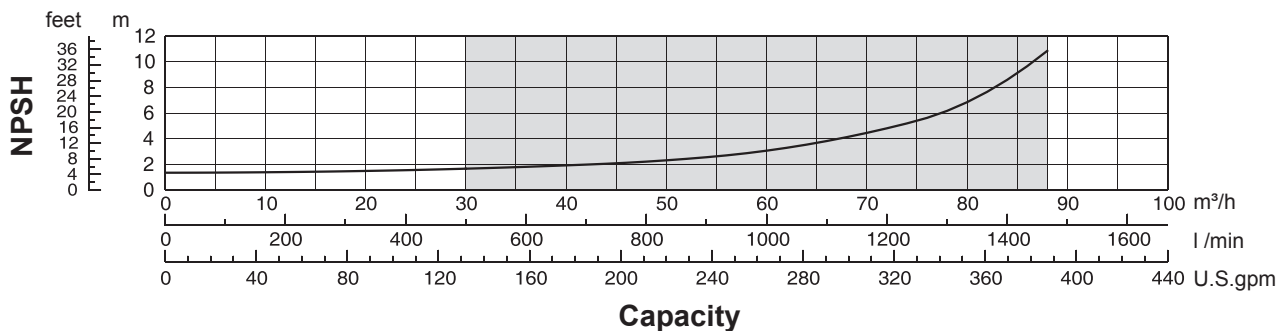
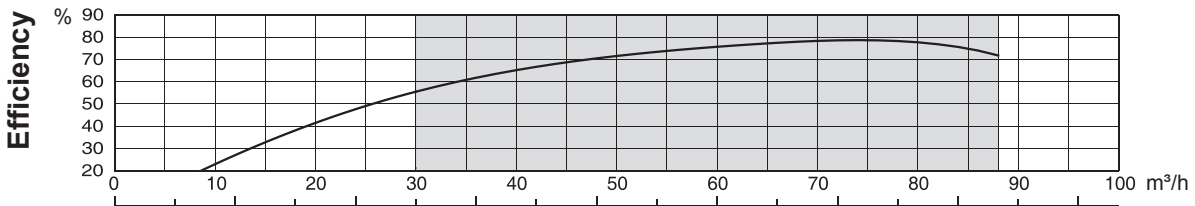
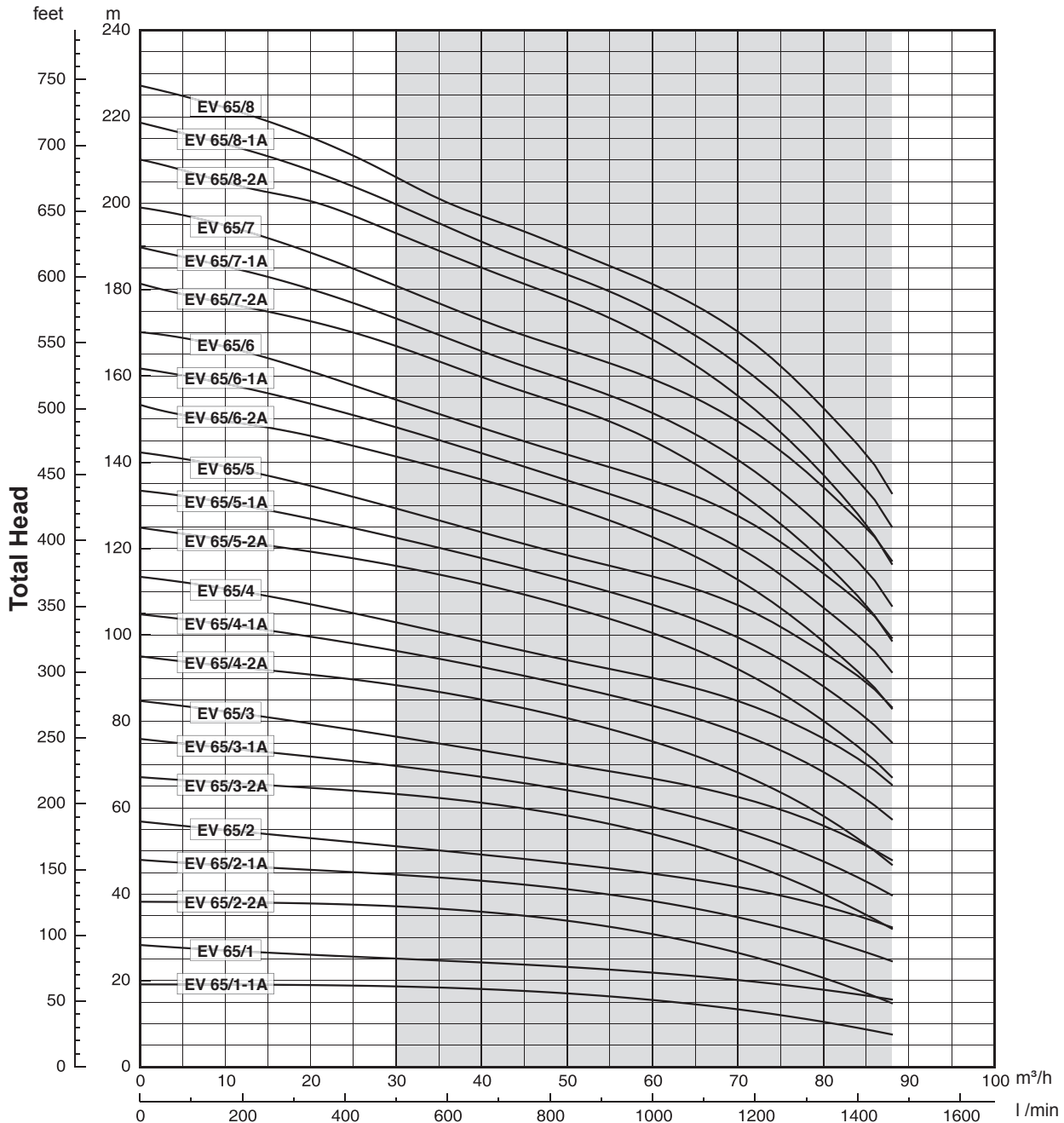

00110098 01/2014

The hydraulic characteristics are guaranteed, according to ISO standard 9906:2012, grade 3B.



It is our policy to continuously develop and improve our products, therefore, we reserve the right to amend specifications without prior notice.

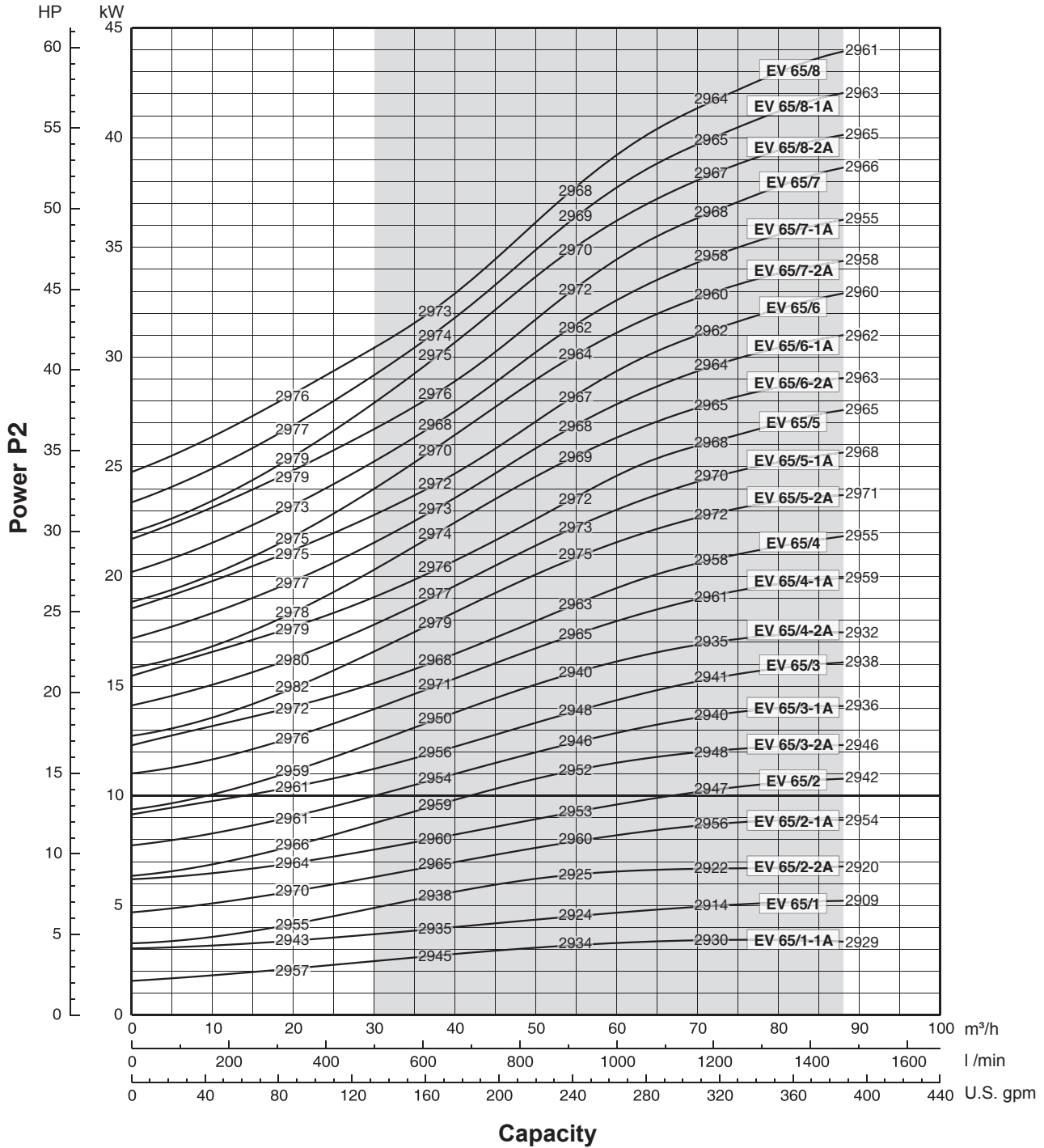

Performance curves of Q, H and P depend on the rpm number according to the following formulae:

$$Q_2 = Q_1 \cdot \left(\frac{n_2}{n_1}\right), \quad H_2 = H_1 \cdot \left(\frac{n_2}{n_1}\right)^2, \quad P_2 = P_1 \cdot \left(\frac{n_2}{n_1}\right)^3, \quad \eta \text{ remains approximately the same.}$$

The rpm number related to the performance curves (Q-H-P) is indicated in the power chart.
 Performance curves (Q-H-P) will change in case a motor with rpm number different from indicated values is used.
 Q=Capacity, H=Head, P=Power, η=Efficiency

Technical data 50Hz

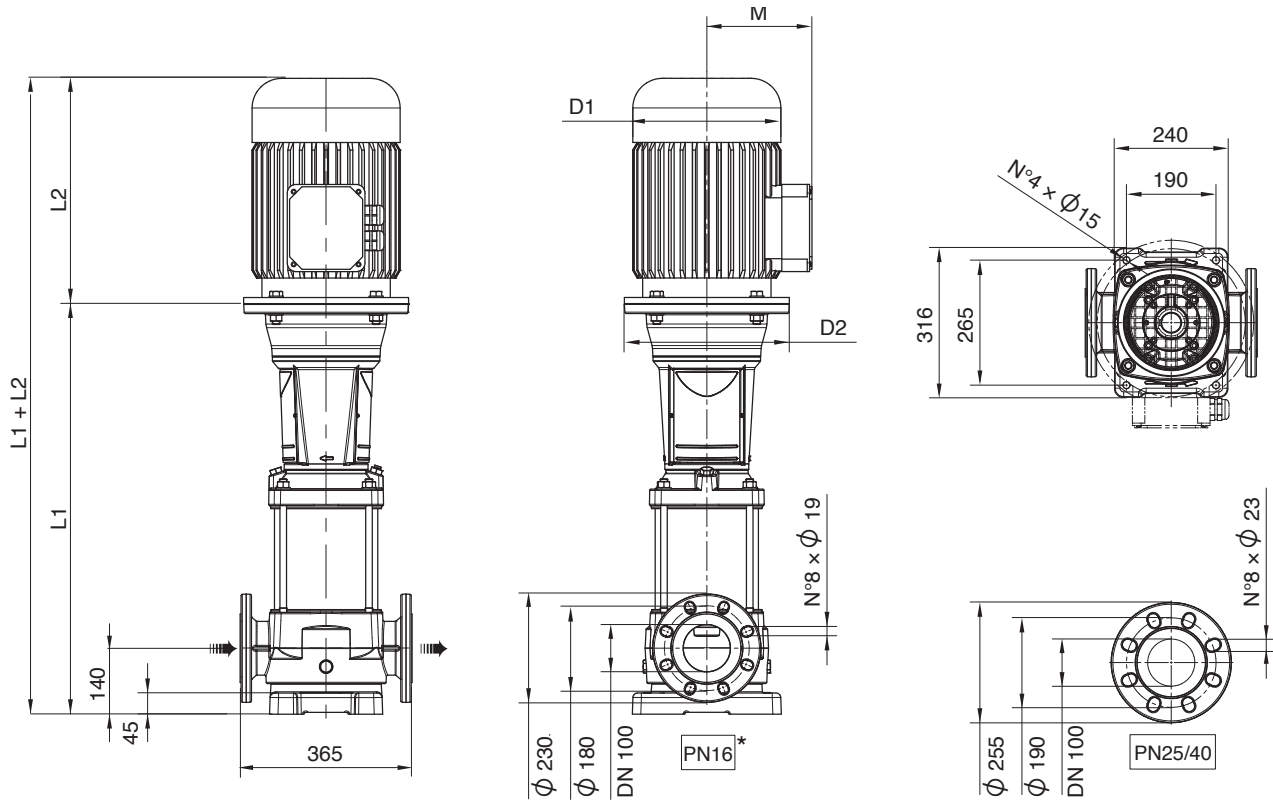

F version: The pump is supplied without counterflanges (Optional accessories, including bolts and joints).

* Available from EV65/1-1A to EV65/6-2A

00114126 10/2013

Pump Model	Motor		Dimensions (mm)						Weight (kg)		
	kW	Dim	L1	L2	M	D1	D2	L1 + L2	Pump	Motor	Electric Pump
EV 65/1-1A	4	112	550,1	306	145	196	170	856,1	61	22,8	83,8
EV 65/1	5,5	132	737,1	328	161	225	300	1065,1	81	34	115
EV 65/2-2A	7,5	132	829,2	350	161	225	300	1179,2	85,5	36	121,5
EV 65/2-1A	11	160	849,2	425	198	248	350	1274,2	88,5	58	146,5
EV 65/2	11	160	849,2	425	198	248	350	1274,2	88,5	58	146,5
EV 65/3-2A	15	160	941,3	476	198	248	350	1417,3	93	64	157
EV 65/3-1A	15	160	941,3	476	198	248	350	1417,3	93	64	157
EV 65/3	18,5	160	941,3	542	235	317	350	1483,3	93	88,9	181,9
EV 65/4-2A	18,5	160	1033,4	542	235	317	350	1575,4	97,5	88,9	186,4
EV 65/4-1A	22	180	1033,4	542	238	317	350	1575,4	98	108,7	206,7
EV 65/4	22	180	1033,4	542	238	317	350	1575,4	98	108,7	206,7
EV 65/5-2A	30	200	1130,5	658	300	399	400	1788,5	105,5	228	333,5
EV 65/5-1A	30	200	1130,5	658	300	399	400	1788,5	105,5	228	333,5
EV 65/5	30	200	1130,5	658	300	399	400	1788,5	105,5	228	333,5
EV 65/6-2A	30	200	1222,6	658	300	399	400	1880,6	110	228	338
EV 65/6-1A	37	200	1222,6	658	300	399	400	1880,6	110	242	352
EV 65/6	37	200	1222,6	658	300	399	400	1880,6	110	242	352
EV 65/7-2A	37	200	1314,7	658	300	399	400	1972,7	114,5	242	356,5
EV 65/7-1A	37	200	1314,7	658	300	399	400	1972,7	114,5	242	356,5
EV 65/7	45	225	1314,7	699	335	465	450	2013,7	117,5	308	425,5
EV 65/8-2A	45	225	1406,8	699	335	465	450	2105,8	122	308	430
EV 65/8-1A	45	225	1406,8	699	335	465	450	2105,8	122	308	430
EV 65/8	45	225	1406,8	699	335	465	450	2105,8	122	308	430

EV 95

Performance curves 50Hz

MEI ≥ 0,70

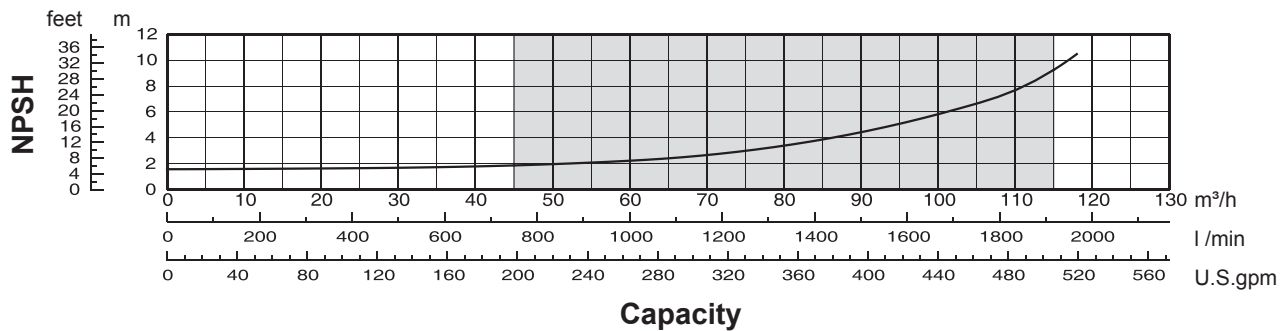
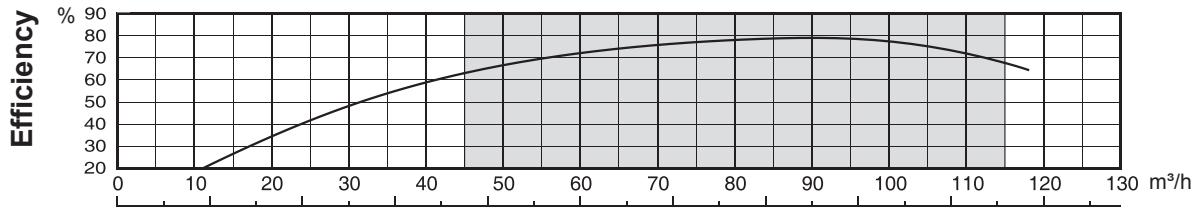
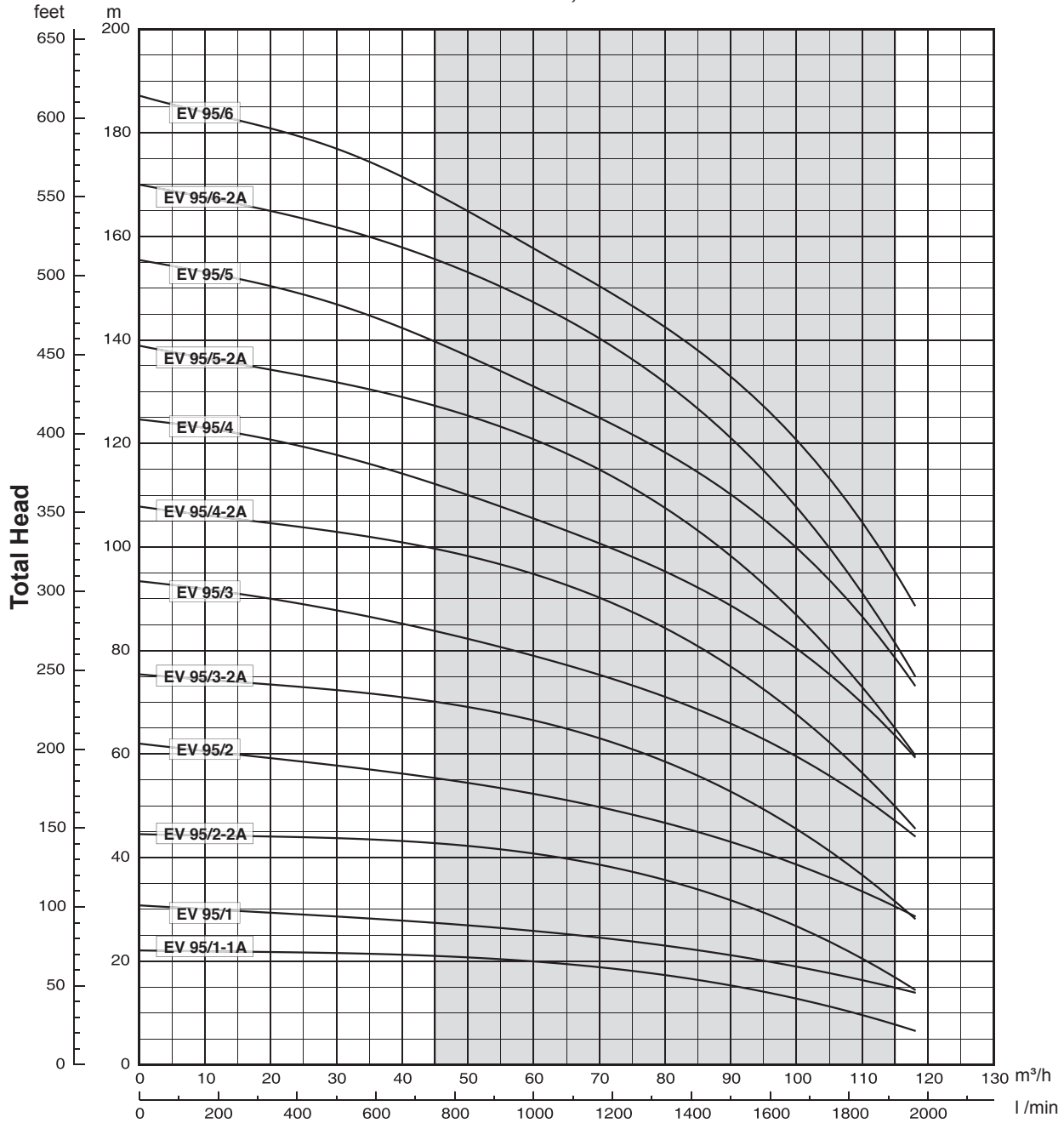

00110099 01/2014

The hydraulic characteristics are guaranteed, according to ISO standard 9906:2012, grade 3B.



It is our policy to continuously develop and improve our products, therefore, we reserve the right to amend specifications without prior notice.

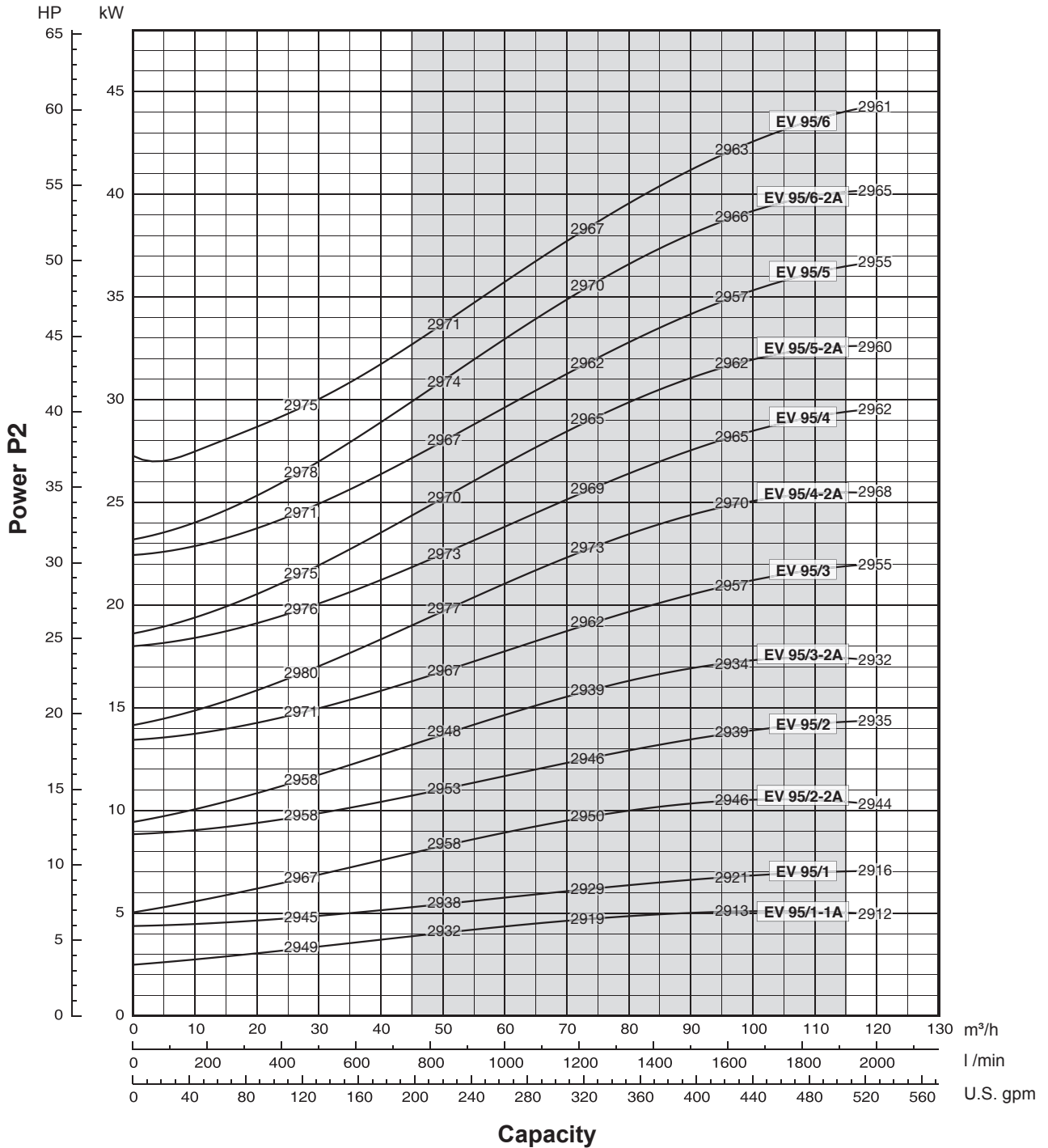

Performance curves of Q, H and P depend on the rpm number according to the following formulae:

$$Q_2 = Q_1 \cdot \left(\frac{n_2}{n_1}\right), \quad H_2 = H_1 \cdot \left(\frac{n_2}{n_1}\right)^2, \quad P_2 = P_1 \cdot \left(\frac{n_2}{n_1}\right)^3, \quad \eta \text{ remains approximately the same.}$$

The rpm number related to the performance curves (Q-H-P) is indicated in the power chart. Performance curves (Q-H-P) will change in case a motor with rpm number different from indicated values is used.

Q=Capacity, H=Head, P=Power, η =Efficiency

Technical data 50Hz

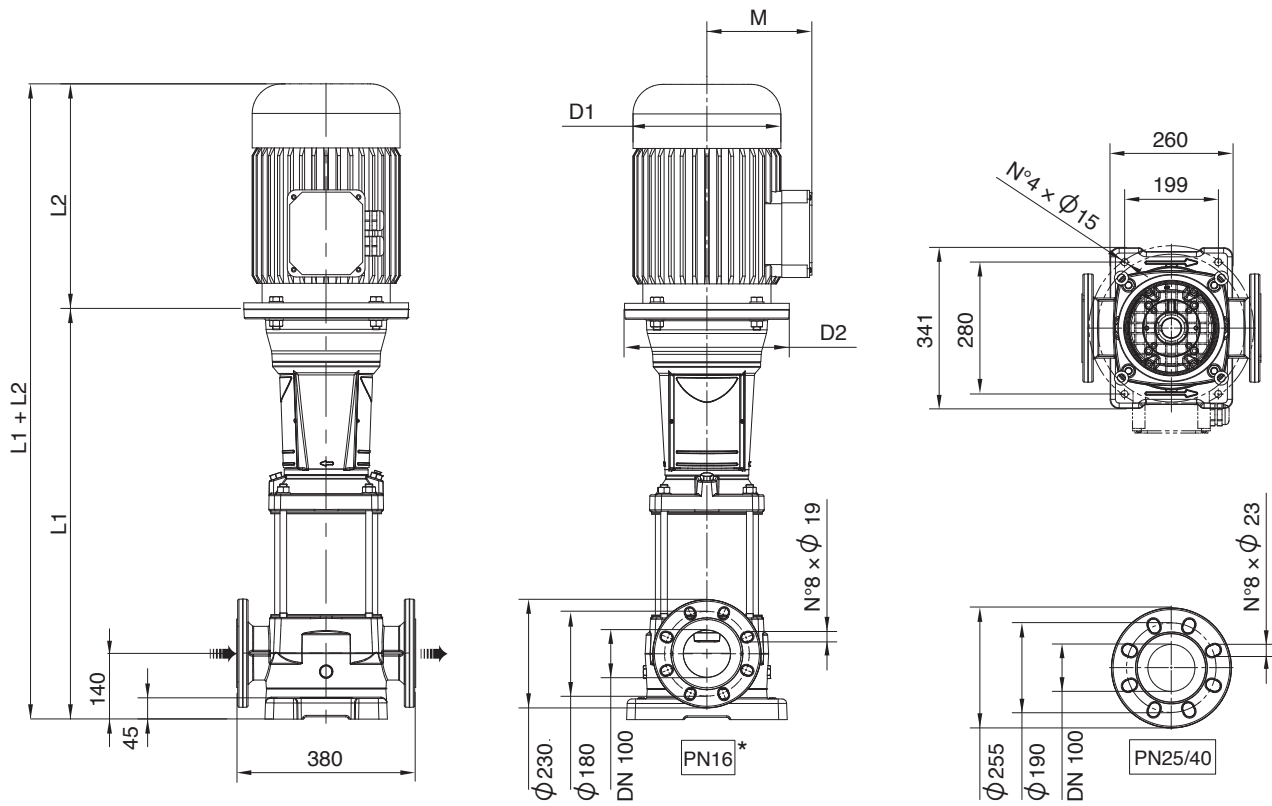

00114127 10/2013

F version: The pump is supplied without counterflanges (Optional accessories, including bolts and joints).

* Available from EV95/1-1A to EV95/5

Pump Model	Motor		Dimensions (mm)						Weight (kg)		
	kW	Dim	L1	L2	M	D1	D2	L1 + L2	Pump	Motor	Electric Pump
EV 95/1-1A	5,5	132	737,1	328	161	225	300	1065,1	82,5	34	116,5
EV 95/1	7,5	132	737,1	350	161	225	300	1087,1	82,5	36	118,5
EV 95/2-2A	11	160	849,2	425	198	248	350	1274,2	89	58	147
EV 95/2	15	160	849,2	476	198	248	350	1325,2	89	64	153
EV 95/3-2A	18,5	160	941,3	542	235	317	350	1483,3	93	88,9	181,9
EV 95/3	22	180	941,3	542	238	317	350	1483,3	93	108,7	201,7
EV 95/4-2A	30	200	1038,4	658	300	399	400	1696,4	100	228	328
EV 95/4	30	200	1038,4	658	300	399	400	1696,4	100	228	328
EV 95/5-2A	37	200	1130,5	658	300	399	400	1788,5	104	242	346
EV 95/5	37	200	1130,5	658	300	399	400	1788,5	104	242	346
EV 95/6-2A	45	225	1222,6	699	335	465	450	1921,6	110,5	308	418,5
EV 95/6	45	225	1222,6	699	335	465	450	1921,6	110,5	308	418,5

EV Series Pump Section and List of Main Components

EV Series Pump Section and List of Main Components

EV 1 - EV 3 - EV 6 - EV 10

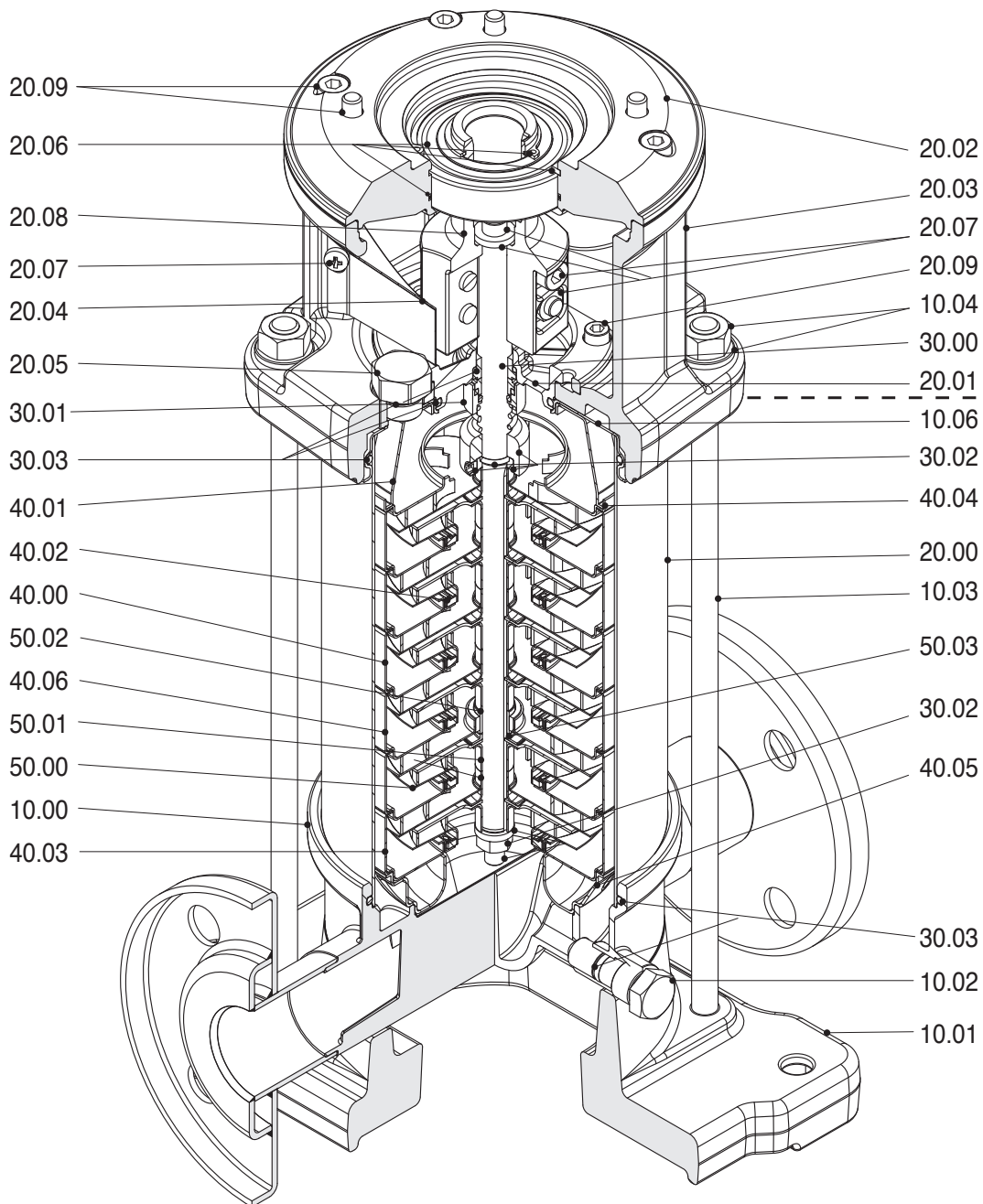

(Configuration up to 4kW)

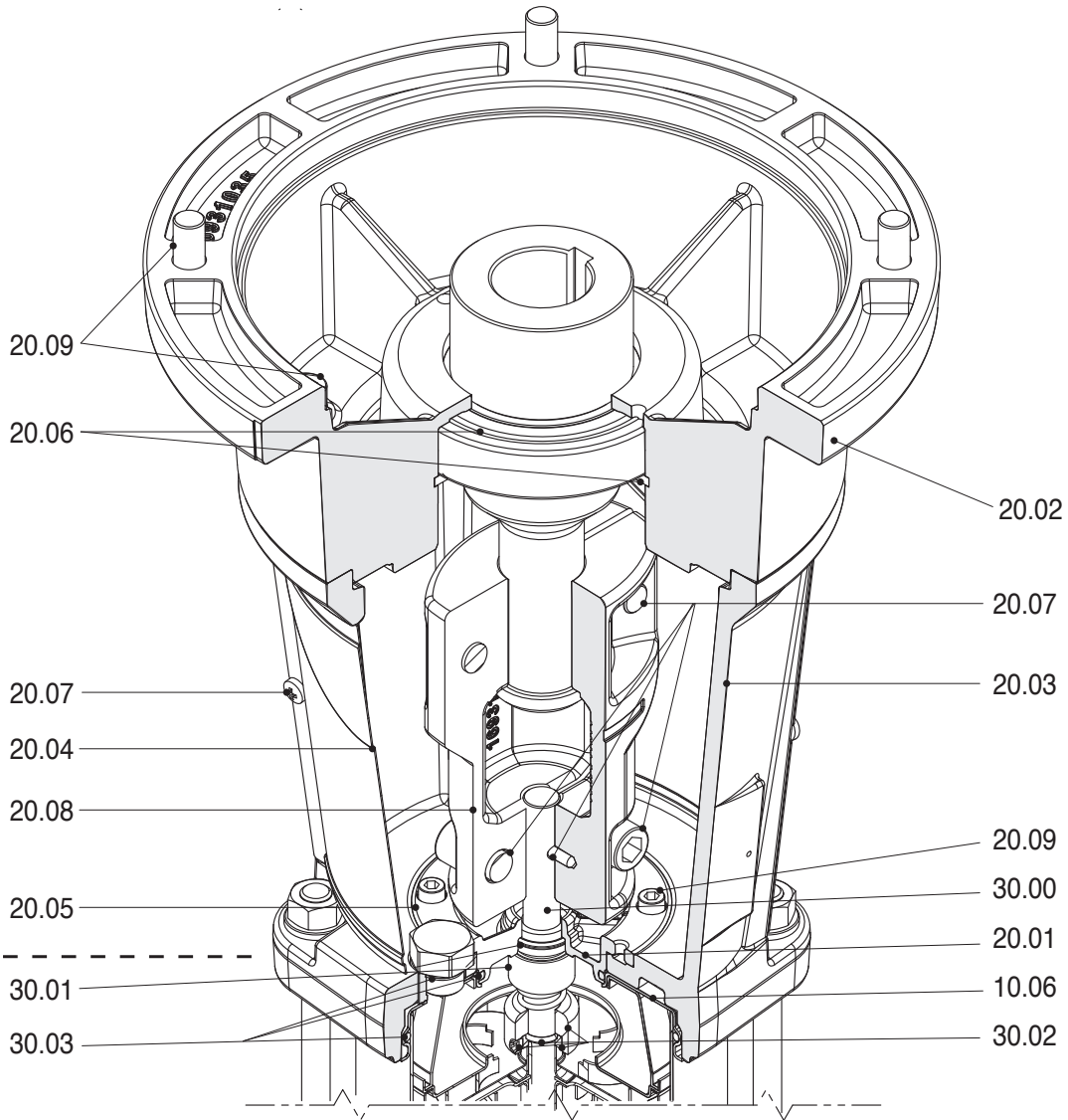

00114112 01/2015

(Configuration from 5,5kW)

N. rif.	Description
10.00	Pump casing
10.01	Pump fixing plate
10.02	Filling and draining plug
10.03	Tie bolt
10.04	Kit nuts and washers
10.06	Upper flange
20.00	Outer Case
20.01	Mechanical seal housing
20.02	Motor flange
20.03	Motor bracket
20.04	Coupling guard
20.05	Filling plugs
20.06	Circlips and bearings, and O-ring
20.07	Coupling fasteners
20.08	Coupling
20.09	Kit motor screws

N. rif.	Description
30.00	Pump shaft
30.01	Kit Mechanical seal
30.02	Mechanical seal fastening kit
30.03	Kit O-rings
40.00	Stage housing and diffuser
40.01	Stage Centering outlet
40.02	Floating neck ring
40.03	Initial stage housing
40.04	Last Stage with diffuser
40.05	Stage Centering inlet
40.06	Stage housing and diffuser with bearing
50.00	Impeller
50.01	Impeller spacer
50.02	Intermediary sleeve
50.03	Intermediary sleeve spacer

EV Series Pump Section and List of Main Components

EV 15 - EV 20

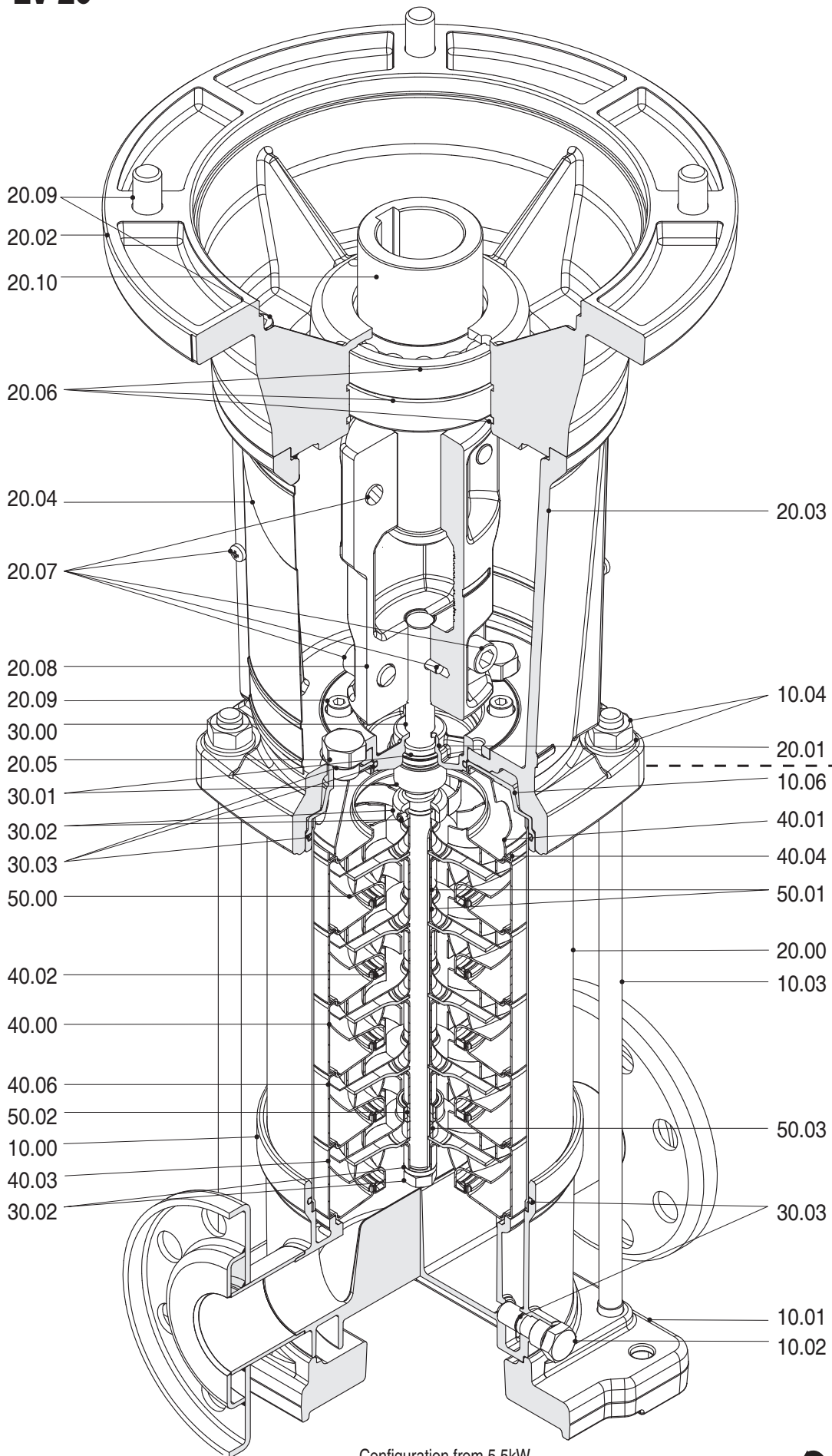

Configuration from 5,5kW

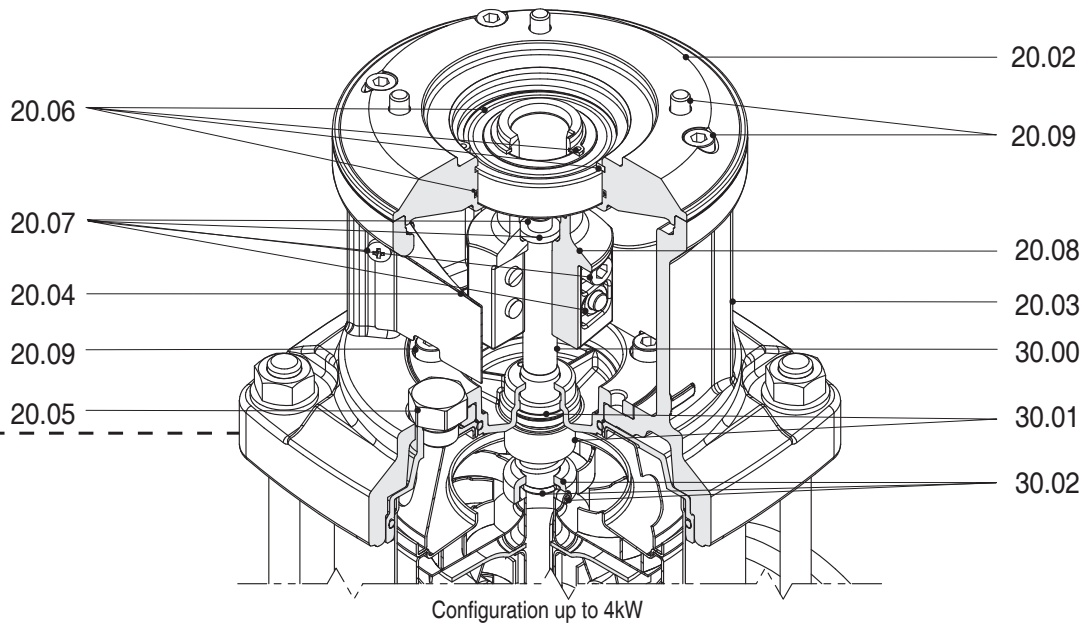

00114114 01/2015

N. rif.	Description
10.00	Pump casing
10.01	Pump fixing plate
10.02	Filling and draining plug
10.03	Tie bolt
10.04	Kit nuts and washers
10.06	Upper Flange
20.00	Outer Case
20.01	Mechanical seal housing
20.02	Motor flange
20.03	Motor bracket
20.04	Coupling guard
20.05	Filling plugs
20.06	Circlips and bearings, and O-ring
20.07	Coupling fasteners
20.08	Coupling
20.09	Kit motor screws

N. rif.	Description
20.10	Motor shaft adapter
30.00	Pump shaft
30.01	Kit Mechanical seal
30.02	Mechanical seal fastening kit
30.03	Kit O-rings
40.00	Stage housing and diffuser
40.01	Stage Centering outlet
40.02	Floating neck ring
40.03	Initial stage housing
40.04	Last Stage with diffuser
40.06	Stage housing and diffuser with bearing
50.00	Impeller
50.01	Impeller spacer
50.02	Intermediary sleeve
50.03	Intermediary sleeve spacer

EV Series Pump Section and List of Main Components

EV 30 - EV 45 - EV 65 - EV 95

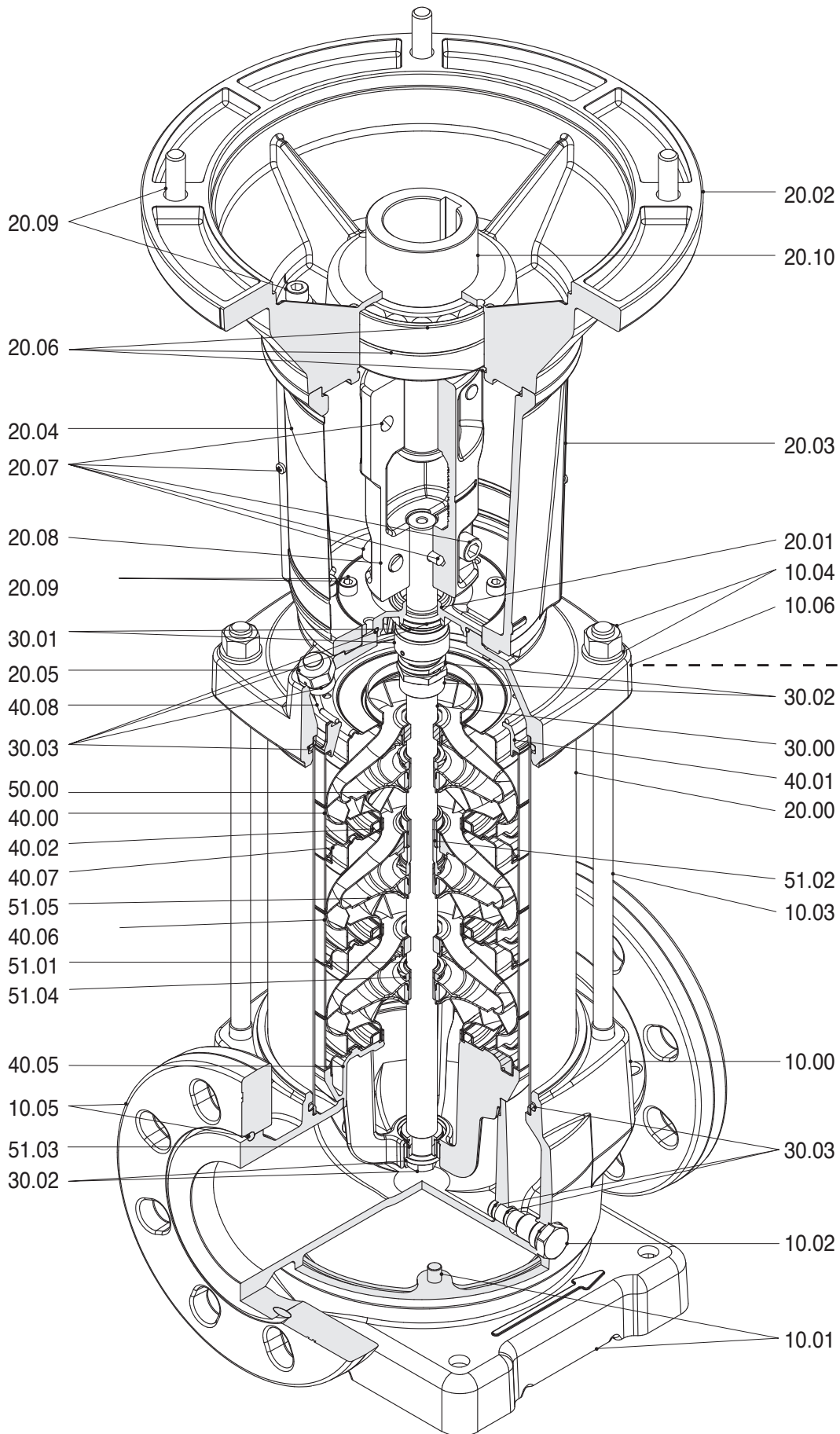

Configuration from 5,5kW

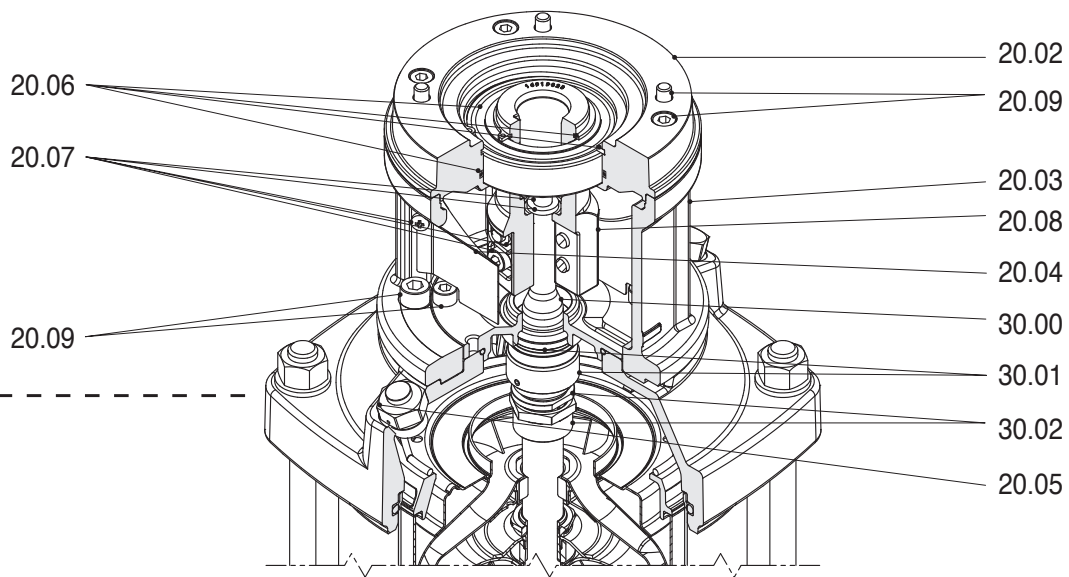

Configuration up to 4kW

00114113 01/2015

N. rif.	Description
10.00	Pump casing
10.01	Pump fixing plate
10.02	Draining plug
10.03	Tie bolt
10.04	Kit nuts and washers
10.05	Kit flanges ring
10.06	Upper Flange
20.00	Outer Case
20.01	Mechanical seal housing
20.02	Motor flange
20.03	Motor bracket
20.04	Coupling guard
20.05	Filling plugs
20.06	Circlips and bearings, and O-ring
20.07	Coupling fasteners
20.08	Coupling
20.09	Kit motor screws
20.10	Motor shaft adapter

N. rif.	Description
30.00	Pump shaft
30.01	Kit Mechanical seal
30.02	Mechanical seal fastening kit
30.03	Kit O-rings
40.00	Stage housing and diffuser
40.01	Stage Centering outlet (only on EV 65/95)
40.02	Floating neck ring
40.05	Stage Centering inlet
40.06	Stage housing and diffuser with bearing
40.07	Flange clamping neck ring
40.08	Spring ring
50.00	Impeller
51.01	Split cone
51.02	Intermediary sleeve nut
51.03	Journal sleeve
51.04	Split cone nut
51.05	Intermediate impeller with screw

EV Series Dimensions of counterflanges

Dimensions of oval counterflanges

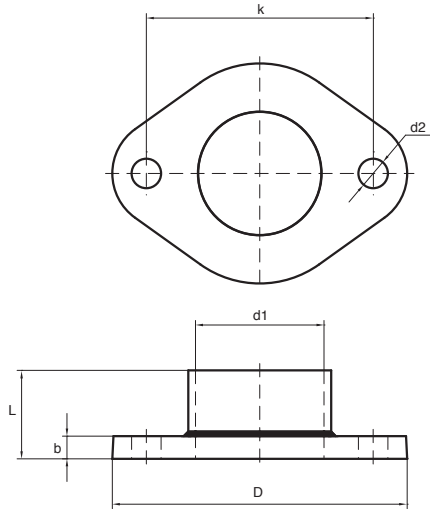

00114101 11/2013

OVAL COUNTERFLANGES								
DN	DIMENSIONS [mm]					HOLES		PN
	D	d1	k	L	b	d2	N°	
32	99	Rp 1" ¼	75	33	8	11		16
		NPT 1" ¼						
40	130	Rp 1" ½	100	35	10	13	2	16
		NPT 1" ½						
50		Rp 2"		39				
		NPT 2"						

Kit round counterflanges available on request; AISI 304

Dimensions of round threaded counterflanges according to EN 1092-1

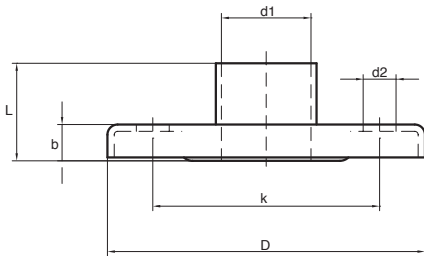

00114101 11/2013

ROUND THREADED COUNTERFLANGES								
DN	DIMENSIONS [mm]					HOLES		PN
	D	d1	k	L	b	d2	N°	
25	115	Rp 1" NPT 1"	85	43	16	14	4	25
32	140	Rp 1" ¼ NPT 1" ¼	100			18		
		40	150		Rp 1" ½ NPT 1" ½	110	18	
50	165				Rp 2" NPT 2"	127	18	
65	185	Rp 2" ½ NPT 2" ½	145	32	18	18	8	16
80	200	Rp 3" NPT 3"	160	34	20			
		100	220	Rp 4" NPT 4"	180	40	20	

Kit round counterflanges available on request:
 DN 25-32-40-50: galvanized steel, AISI 304, AISI 316L
 DN 65-80-100: galvanized steel, AISI 316

Dimensions of welding round counterflanges according to EN 1092-1

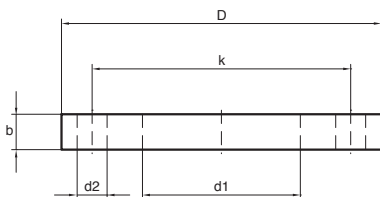

00114101 11/2013

WELDING ROUND COUNTERFLANGES								
DN	DIMENSIONS [mm]					HOLES		PN
	D	d1	k	L	b	d2	N°	
65	185	77,5	145	-	22	18	8	25/40
80	200	90,5	160		24			
100	235	116	190		26	22		

Kit round counterflanges available on request; AISI 316



Vertical S.r.l.
via Asolo, 7
36031 Dueville (Vicenza) - Italy
Tel. +39 0444 361114
Fax +39 0444 365247
P.IVA e C.F. 00558130241
e-mail: sales@vertical.vi.it
www.etechpumps.com

*Single member - Company subject to the control
and coordination of Franklin Electric Co., Inc.*