



# E-Tech



Franklin Electric

***HORIZONTAL MULTISTAGE PUMPS***

***50Hz***

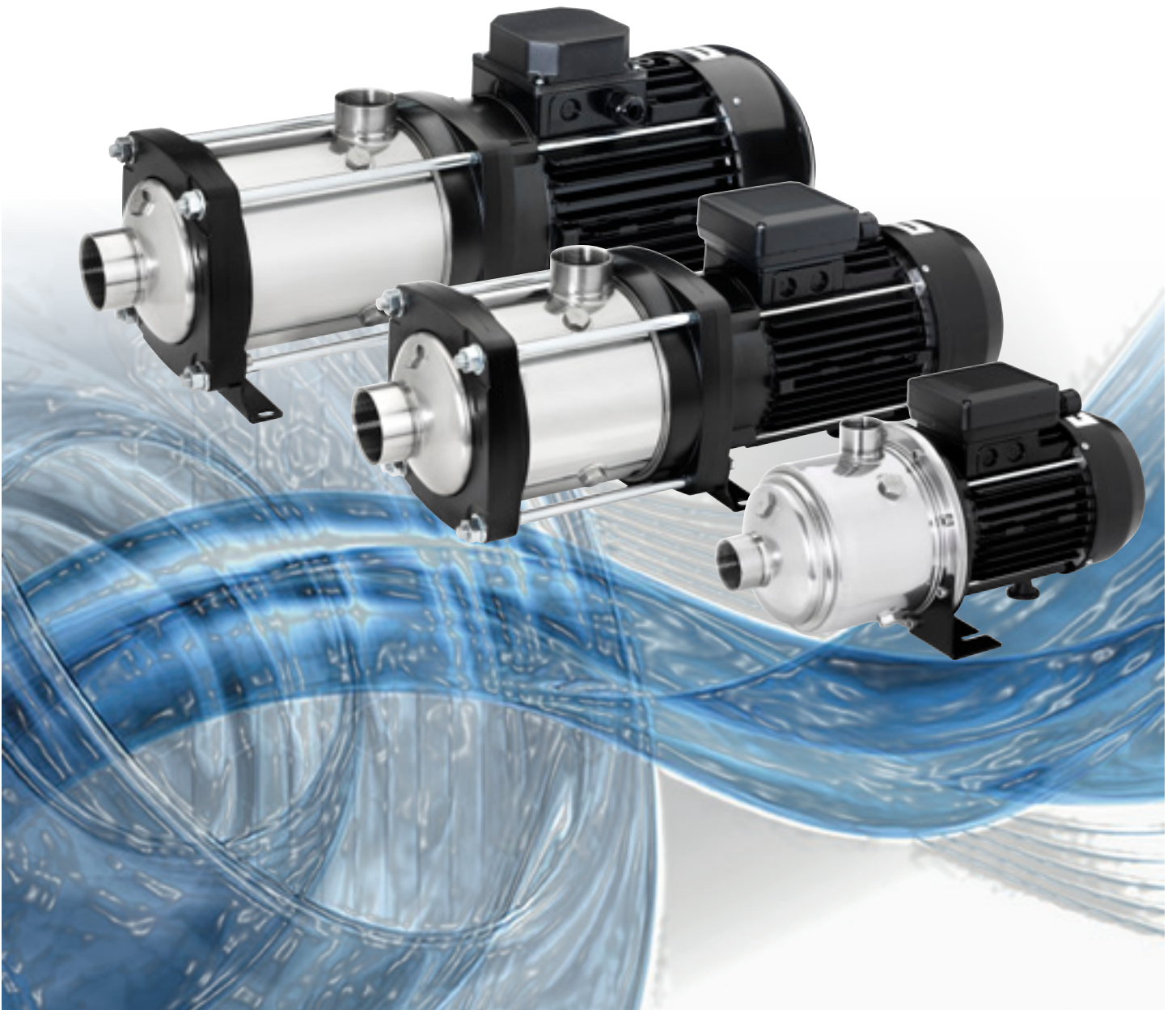

# INDEX

EH Stainless Steel Horizontal Multistage Pump .....	2
General Product Curves .....	3
Material Table .....	3
Table of hydraulic performances at 50Hz EH 3 - 5 - 9 - 15 - 20 .....	4
<hr/>	
Technical data and Performance Curves 50Hz	
EH 3. ....	6
EH 5. ....	8
EH 9. ....	10
EH 15. ....	12
EH 20 .....	14
<hr/>	
Pump Section and List of Main Components .....	16
<hr/>	

# Stainless Steel Horizontal Multistage Pumps

## APPLICATIONS

- Small domestic and industrial systems / Domestic water supply
- Water distribution / pressure boosting
- Irrigation / Gardening / Sprinklers / Rainwater collection
- Industrial plants / Wash down unit
- Cooling and chilling / Heating and conditioning / Air conditioning systems
- Other various installations

## FEATURES

- Compact close-coupled design, robust and rust resistant / Superior efficiency and performances
- Flexible application base plate
- Floating neck ring in PTFE/PPS
- Heavy duty oversize motor shaft
- Impellers and diffusers are made of stainless steel in order to achieve durability
- Easy maintenance
- Possibility of removing the hydraulic stack without disconnecting the pump body from the pipelines
- Strong and leak-proof motor rolling bearing fitted in the motor bracket
- Pumping of clear non-loaded fluids
- Mechanical seal carbon/ceramic/EPDM - EH 3 - 5 - 9 / Type E0
- Mechanical seal carbon/silicon carbide/EPDM - EH 15 - 20 / Type E1

## SPECIFICATIONS

- Capacities up to 29 m<sup>3</sup>/h at 50Hz
- Heads up to 104 m at 50Hz
- Discharge inlet 1"¼ Rp EH 3/5 - 1"½ Rp EH 9 - 2" Rp EH 15/20
- Discharge outlet 1" Rp EH 3/5 - 1"¼ Rp EH 9 - 1"½ Rp EH 15/20
- Maximum working pressure 10 Bar
- Maximum allowable amount of sand 50 g/m<sup>3</sup>
- Maximum ambient temperature 40°C
- Liquid temperature range -15°C to 100°C
- Maximum solids size up to 2 mm
- Asynchronous, TEFC, Class F insulation, IP55 protection motor
- Capacitor inside terminal box
- Single phase motors with built-in thermal relay
- Maximum number of starts per hour: 20

## AVAILABLE ON REQUEST

- Special mechanical seal
- Discharge inlet/outlet NPT

## PUMP IDENTIFICATION CODE

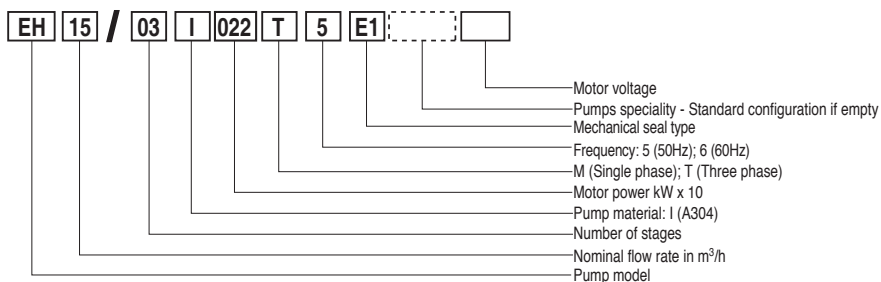

0114370E 072015

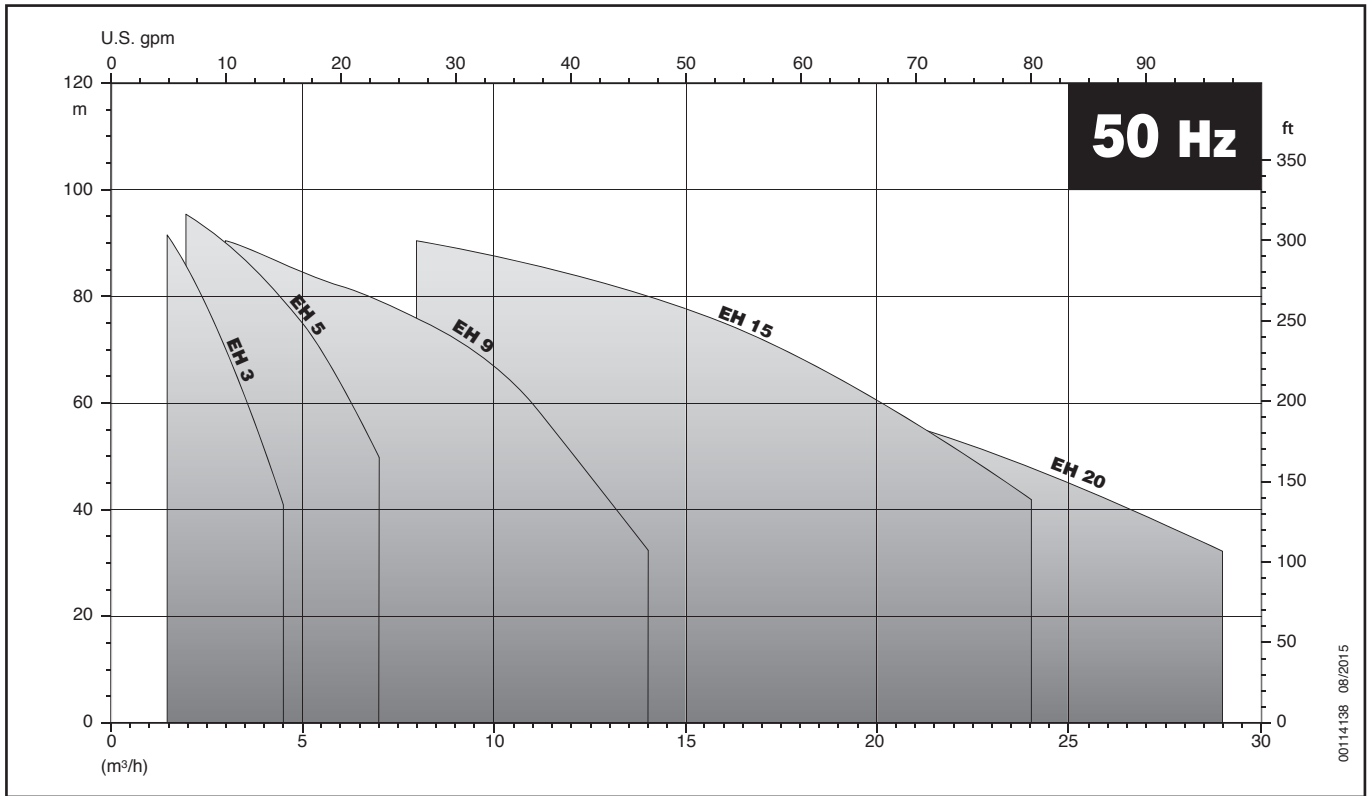

MATERIAL IN CONTACT WITH THE LIQUID				
Pos.	PARTS DESCRIPTION	MATERIAL		
		Type	AISI	DIN / EN
20.00	Pump casing	Stainless steel	AISI 304	1.4301
20.02	Seal housing	Stainless steel	AISI 304	1.4301
20.05	Filling and drain plug	Stainless steel	AISI 304	1.4301
20.07	Inlet cover	Stainless steel	AISI 304	1.4301
30.05	O-ring	EPDM		
30.06	Mechanical seal	Carbon/ceramic/EPDM – Carbon/Silicon carbide/EPDM		
30.08	Pump shaft	Stainless steel	AISI 304	1.4301
30.09	Screws and washers	Stainless steel	AISI 304	1.4301
40.00				
40.01	Diffuser/s	Stainless steel	AISI 304	1.4301
40.03				
50.00				
50.01	Impeller/s with spacers	Stainless steel	AISI 304	1.4301

# EH 3-5-9-15-20

## TABLE OF HYDRAULIC PERFORMANCES AT 50Hz

PUMP TYPE	RATED POWER		Q = DELIVERY																								
			l/min	0	25	33	42	50	58	67	75	83	92	100	117	133	150	167	183	233	267	300	333	367	417	467	483
	m³/h	0	1,5	2	2,5	3	3,5	4	4,5	5	5,5	6	7	8	9	10	11	14	16	18	20	22	25	28	29		
	US GMP	0	6,6	8,8	11,0	13,2	15,4	17,6	19,8	22,0	24,2	26,4	30,8	35,2	39,6	44,0	48,4	61,6	70,4	79,2	88,0	96,8	110,0	123,2	127,6		
kW		HP		H = TOTAL HEAD METERS COLUMN OF WATER																							
EH 3/2	0,33	0,45	23	21	19,5	18	16,5	14,5	12,5	10																	
EH 3/3	0,45	0,6	33,5	30,5	29	26,5	24	21	17,5	14																	
EH 3/4	0,55	0,75	44,5	40	37,5	34,5	31	27	23	18																	
EH 3/5	0,75	1	55	49	46	42	37	32,5	27	21																	
EH 3/6	0,9	1,2	67,5	61	57	53	47	41,5	35	28																	
EH 3/7	1,1	1,5	78	70,5	66	60,5	54	47,5	40	32																	
EH 3/8	1,3	1,8	90	82	77	71	64	56	47	38																	
EH 3/9	1,5	2	101	91,5	85,5	79	70,5	61,5	52	41																	
EH 5/2	0,45	0,6	23,5		21,5	21	20,5	19,5	19	18	17	16	25	11,5													
EH 5/3	0,55	0,75	34,5		31,5	31	29,5	28,5	27,5	26	25	23	21	16													
EH 5/4	0,9	1,2	46,5		43	42	41	39,5	38	36	34	32	29	23													
EH 5/5	1,1	1,5	58		53	51,5	50	48,5	46,5	44	41,5	38,5	35,5	27,5													
EH 5/6	1,3	1,8	70		64,5	63	61	59	56,5	54	51	47,5	43,5	34													
EH 5/7	1,5	2	81,5		74,5	72,5	70	68	65	61,5	58	54	49,5	38,5													
EH 5/8	1,5	2	92,5		84	82	79	76,5	73	69	65	60	54,5	42													
EH 5/9	1,85	2,5	104		95,5	93	90,5	87,5	83,5	79,5	75	70	64	50													
EH 9/2	0,75	1	23,5				22	21,5	21	20,5	20	20	19,5	18,5	18	17	15,5	13,5	6,5								
EH 9/3	1,1	1,5	35,5				33	32,5	32	31,5	31	30,5	30	28,5	27,5	26	24	21	11								
EH 9/4	1,5	2	48				45	44,5	43,5	43	42	41,5	41	39,5	38	36	33	29,5	16								
EH 9/5	1,85	2,5	59,5				55,5	55	54	53	52	51	50	48,5	46,5	44	40,5	36	18,5								
EH 9/6	2	2,7	71				66	65	64	62,5	61,5	60	59	57	54,5	51	47	41,5	21								
EH 9/7	3	4	84				79,5	78,5	77,5	76	74,5	73,5	72	70	67	64	59,5	53,5	29,5								
EH 9/8	3	4	96				90,5	89,5	88	86	84,5	83	82	79,5	76	72,5	67	60	32,5								
EH 15/2	1,5	2	29												26	25,5	25,5	25	23	21,5	19,5	17,5	14,5	9,5			
EH 15/3	2,2	3	44												39,5	39	38	37,5	34,5	32,5	29,5	26	22	14,5			
EH 15/4	3	4	58,5												53	52	51,5	50,5	47	44	40	35,5	30	20			
EH 15/5	4	5,5	73												65,5	64,5	63,5	62,5	57,5	54	49	43,5	36,5	24			
EH 15/6	5,5	7,5	87,5												79,5	78	77	75,5	71	67	61,5	54	46	31,5			
EH 15/7	5,5	7,5	102												92	90,5	89	87,5	82	77,5	70,5	62	52,5	36			
EH 20/2	2,2	3	31												28,5	28	27,5	27	26	25	24	22,5	20,5	16,5	12	10	
EH 20/3	3	4	46,5												43	42,5	41,5	41	39,5	38	36,5	34,5	31,5	25,5	19	16	
EH 20/4	4	5,5	62,5												58	57	56	55,5	53,5	51,5	49,5	46,5	42,5	34,5	26	22	
EH 20/5	5,5	7,5	78,5												72,5	71,5	70,5	69,5	67	64,5	62	58,5	53,5	43,5	32,5	28	

---

# **EH Series**

## **Technical data and Performance curves**

**EH 3 50Hz**

**EH 5 50Hz**

**EH 9 50Hz**

**EH 15 50Hz**

**EH 20 50Hz**

## Technical data 50Hz

Pumps model		NUMBER OF STAGES	POWER		INPUT POWER	INTERNAL CAPACITOR		RATED CURRENT		
Single-phase 220-240V 50Hz	Three-phase 380-415V 50Hz		kW	HP		kW	μF	V	Single-phase 220-240V 50Hz	Three-phase 220-240V 50Hz 380-415V 50Hz
EH 3/2	EH 3/2T	2	0.33	0.45	0.44	16	450	2.5	2.4	1.4
EH 3/3	EH 3/3T	3	0.45	0.6	0.59	16	450	3.0	2.6	1.5
EH 3/4	EH 3/4T	4	0.55	0.75	0.75	16	450	3.7	2.9	1.7
EH 3/5	EH 3/5T	5	0.75	1	0.90	16	450	4.3	3.1	1.8
EH 3/6	EH 3/6T	6	0.9	1.2	1.14	30	450	5.4	4.3	2.5
EH 3/7	EH 3/7T	7	1.1	1.5	1.29	30	450	6.0	4.7	2.7
EH 3/8	EH 3/8T	8	1.3	1.8	1.46	30	450	6.9	5.5	3.2
EH 3/9	EH 3/9T	9	1.5	2	1.61	30	450	7.5	5.9	3.4

- Single-phase motors: 220-240 V ± 5 % / 50Hz. Thermal protection built into the motor.
- Three-phase motors: 380-415 V ± 5 % / 50Hz. Thermal protection to be provide into the starter pale by the installer.

## Dimensions and weights

Pump model		Dimensions													Weight (kg)	
Single-phase 220-240V 50Hz	Three-phase 380-415V 50Hz	A mm	E mm	C mm	D mm	F mm	G mm	DN1	DN2	ØB mm	H mm	L1 mm	L2 mm	L3 mm	1- Single-phase	3- Three-phase
EH 3/2	EH 3/2T	103	258	139,6	173	361	117	Rp 1"¼	Rp 1"	144	70	70	100,6	-	11,2	11
EH 3/3	EH 3/3T	103	258	139,6	173	361	117			144	207	70	100,6	-	11,3	11,1
EH 3/4	EH 3/4T	127	258	163,6	197	385	117			144	207	70	100,6	-	11,9	11,6
EH 3/5	EH 3/5T	151	258	187,6	221	409	117			144	207	70	100,6	-	12,4	12,2
EH 3/6	EH 3/6T	175	258	211,6	245	433	117			144	207	70	100,6	-	14,4	14,2
EH 3/7	EH 3/7T	199	258	235,6	269	457	117			144	207	70	100,6	180	15	14,7
EH 3/8	EH 3/8T	223	300	259,6	293	523	124			162	214	70	128,1	204	18,8	18,6
EH 3/9	EH 3/9T	247	300	283,6	317	547	124			162	214	70	128,1	228	19,4	19,1

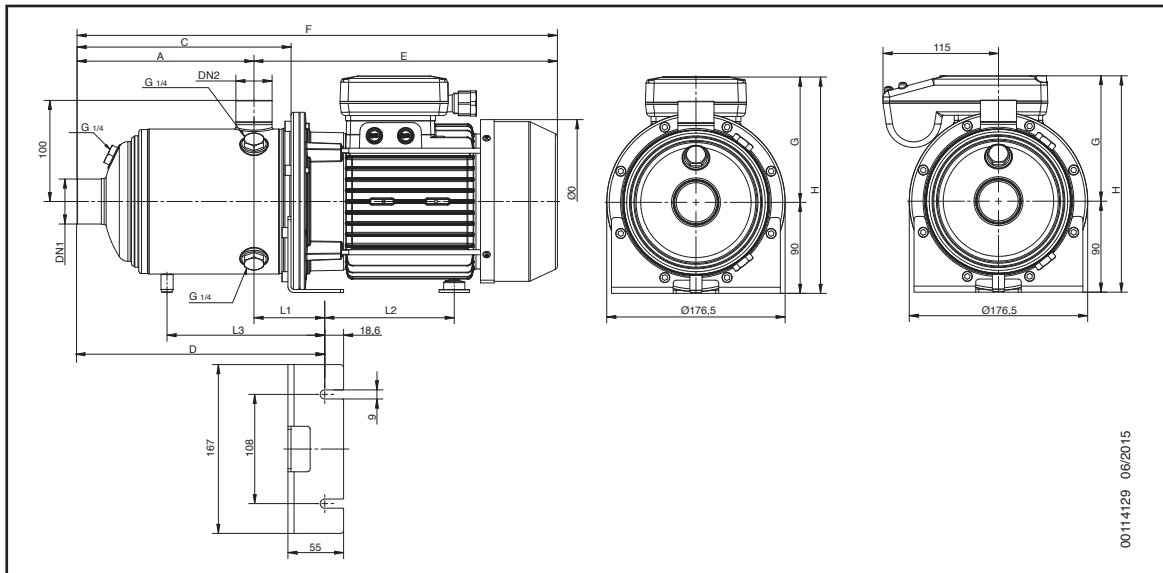

00114129 06/2015

## Performance curves 50Hz

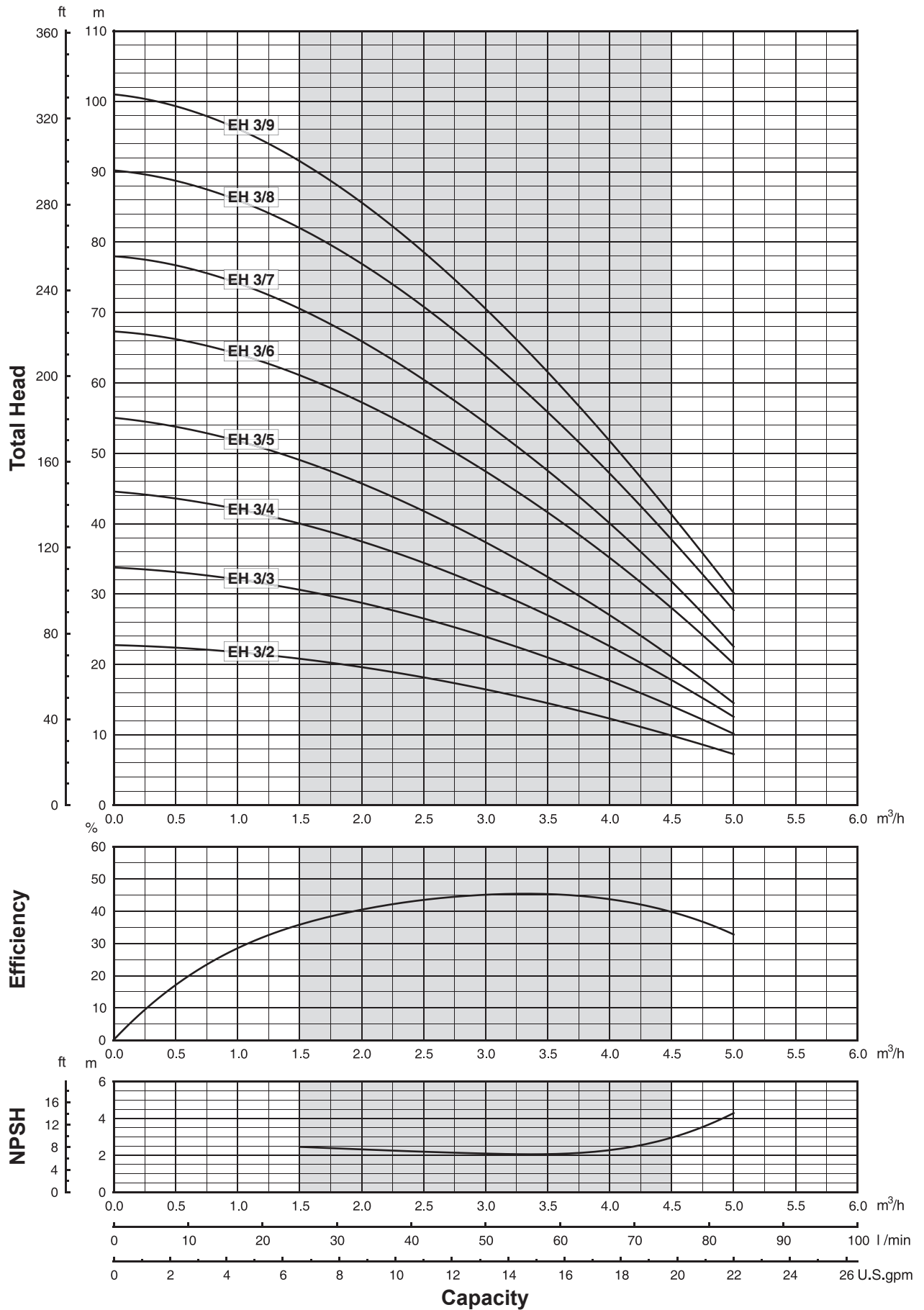

00110059 09/2015



## Technical data 50Hz

Pumps model		NUMBER OF STAGES	POWER		INPUT POWER	INTERNAL CAPACITOR		RATED CURRENT		
Single-phase 220-240V 50Hz	Three-phase 380-415V 50Hz		kW	HP		kW	μF	V	Single-phase 220-240V 50Hz	Three-phase 220-240V 50Hz   380-415V 50Hz
EH 5/2	EH 5/2T	2	0.45	0.6	0.58	16	450	3.0	2.6	1.5
EH 5/3	EH 5/3T	3	0.55	0.75	0.80	16	450	3.9	2.9	1.7
EH 5/4	EH 5/4T	4	0.9	1.2	1.10	30	450	5.3	4.3	2.5
EH 5/5	EH 5/5T	5	1.1	1.5	1.33	30	450	6.2	4.7	2.7
EH 5/6	EH 5/6T	6	1.3	1.8	1.56	30	450	7.3	5.7	3.3
EH 5/7	EH 5/7T	7	1.5	2	1.79	30	450	8.2	6.2	3.6
EH 5/8	EH 5/8T	8	1.5	2	2.00	30	450	8.9	6.6	3.8
-	EH 5/9T	9	1.85	2.5	2.30	-	-	-	7.1	4.1

- Single-phase motors: 220-240 V ± 5 % / 50Hz. Thermal protection built into the motor.
- Three-phase motors: 380-415 V ± 5 % / 50Hz. Thermal protection to be provide into the starter pale by the installer.

## Dimensions and weights

Pump model		Dimensions													Dimensions	
Single-phase 220-240V 50Hz	Three-phase 380-415V 50Hz	A mm	E mm	C mm	D mm	F mm	G mm	DN1	DN2	ØB mm	H mm	L1 mm	L2 mm	L3 mm	1- Single-phase	3- Three-phase
EH 5/2	EH 5/2T	103	258	139,6	173	361	117	Rp 1"¼	Rp 1"	144	207	70	100,6	-	11,2	11
EH 5/3	EH 5/3T	103	258	139,6	173	361	117			144	207	70	100,6	-	11,4	11,1
EH 5/4	EH 5/4T	127	258	163,6	197	385	117			144	207	70	100,6	-	13,4	13,1
EH 5/5	EH 5/5T	151	258	187,6	221	409	117			144	207	70	100,6	-	13,9	13,7
EH 5/6	EH 5/6T	175	300	211,6	245	475	124			162	214	70	128,1	-	17,7	17,5
EH 5/7	EH 5/7T	199	300	253,6	269	499	124			162	214	70	128,1	180	18,3	18
EH 5/8	EH 5/8T	223	300	259,6	293	523	124			162	214	70	128,1	204	18,8	18,6
-	EH 5/9T	247	300	283,6	317	547	124			162	214	70	128,1	228	-	19,1

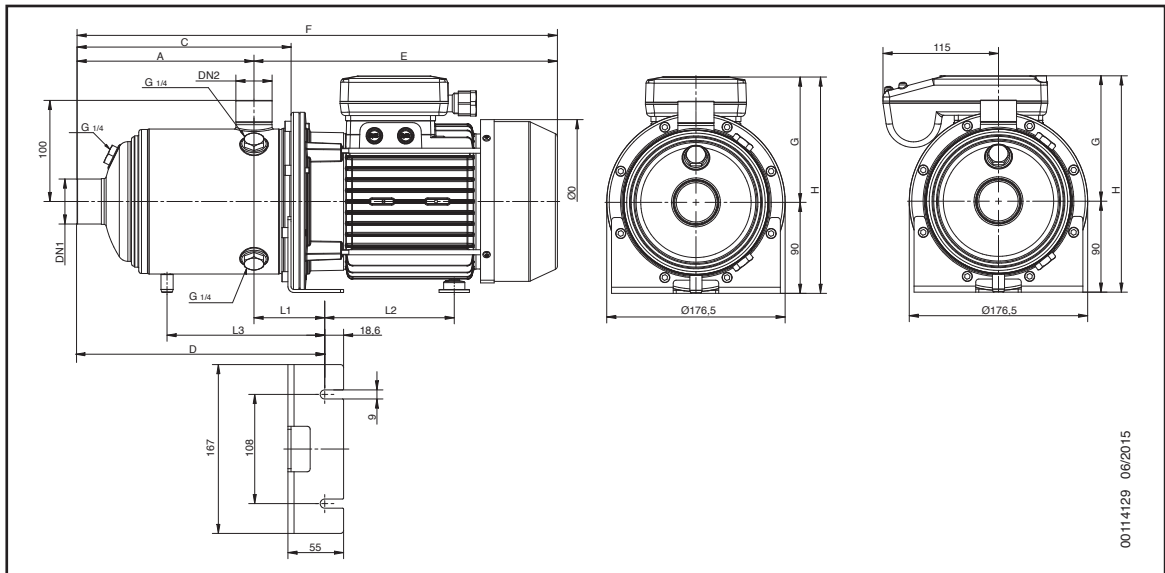

00114129 06/2015

## Performance curves 50Hz

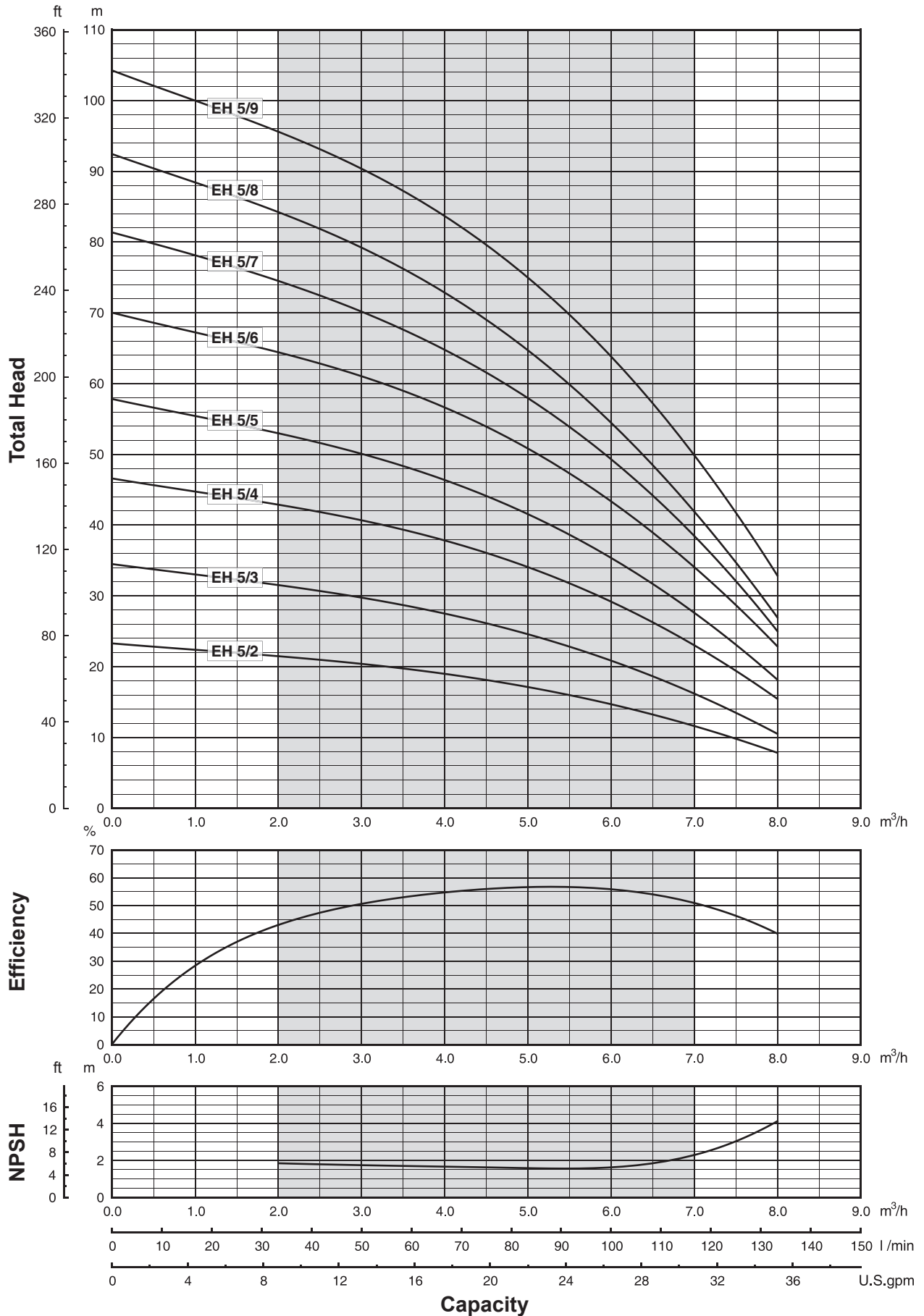

## Technical data 50Hz

Pumps model		NUMBER OF STAGES	POWER		INPUT POWER	INTERNAL CAPACITOR		RATED CURRENT		
Single-phase 220-240V 50Hz	Three-phase 380-415V 50Hz		kW	HP		kW	μF	V	Single-phase 220-240V 50Hz	Three-phase 220-240V 50Hz 380-415V 50Hz
EH 9/2	EH 9/2T	2	0.75	1	0.90	16	450	4.3	3.1	1.8
EH 9/3	EH 9/3T	3	1.1	1.5	1.37	30	450	6.4	4.7	2.7
EH 9/4	EH 9/4T	4	1.5	2	1.77	30	450	8.2	6.1	3.5
-	EH 9/5T	5	1.85	2.5	2.21	-	-	-	6.9	4.0
-	EH 9/6T	6	2	2.7	2.61	-	-	-	7.8	4.5
-	EH 9/7T	7	3	4	3.18	-	-	-	11	6.4
-	EH 9/8T	8	3	4	3.59	-	-	-	12	6.9

- Single-phase motors: 220-240 V ± 5 % / 50Hz. Thermal protection built into the motor.
- Three-phase motors: 380-415 V ± 5 % / 50Hz. Thermal protection to be provide into the starter pale by the installer.

## Dimensions and weights

Pumps model		Dimensions													Weight (kg)		
Single-phase 220-240V 50Hz	Three-phase 380-415V 50Hz	A mm	E mm	C mm	D mm	F mm	G mm	DN1	DN2	ØB mm	H mm	L1 mm	L2 mm	L3 mm	1~ Single-phase	3~ Three-phase	
EH 9/2	EH 9/2T	118	262	158,6	192	380	120	Rp 1" ½	Rp 1" ¼	144	207	74	100,6	-	11,5	11,3	
EH 9/3	EH 9/3T	118	262	158,6	192	380	120			144	207	74	100,6	-	-	13,1	12,9
EH 9/4	EH 9/4T	148	304	188,6	222	452	124			162	214	74	128,1	-	-	17,1	16,8
-	EH 9/5T	178	304	218,6	252	482	124			162	214	74	128,1	-	-	-	17,5
-	EH 9/6T	208	304	248,6	282	512	124			162	214	74	128,1	192,1	-	-	18,1
-	EH 9/7T	238	349	278,6	312	587	131			179	221	74	171,6	222,1	-	-	25,5
-	EH 9/8T	268	349	308,6	342	617	131			179	221	74	171,6	252,1	-	-	26,1

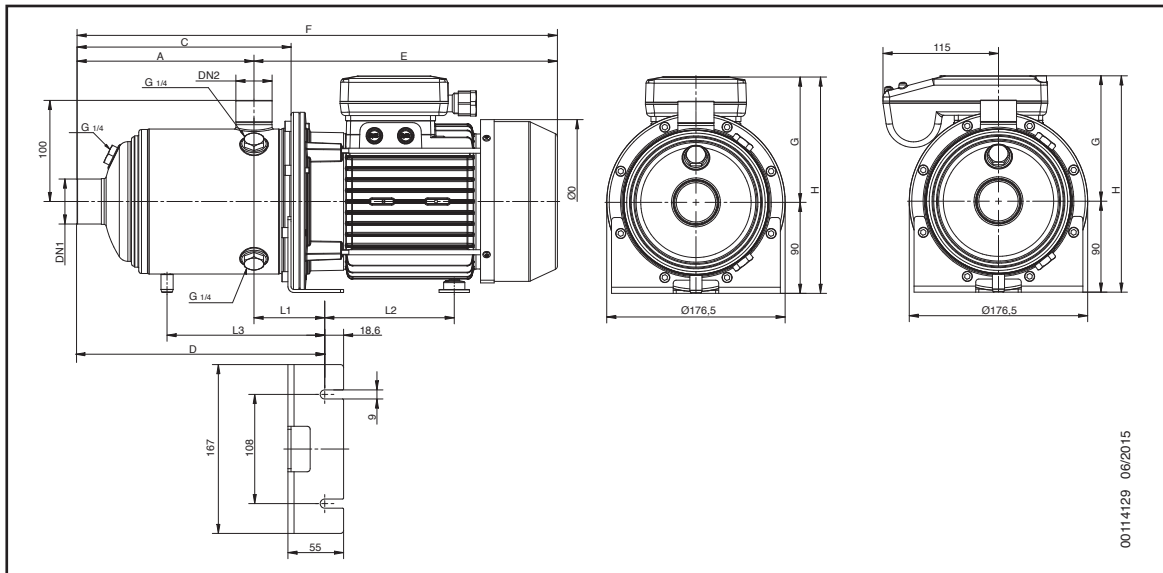

00114129 06/2015

## Performance curves 50Hz

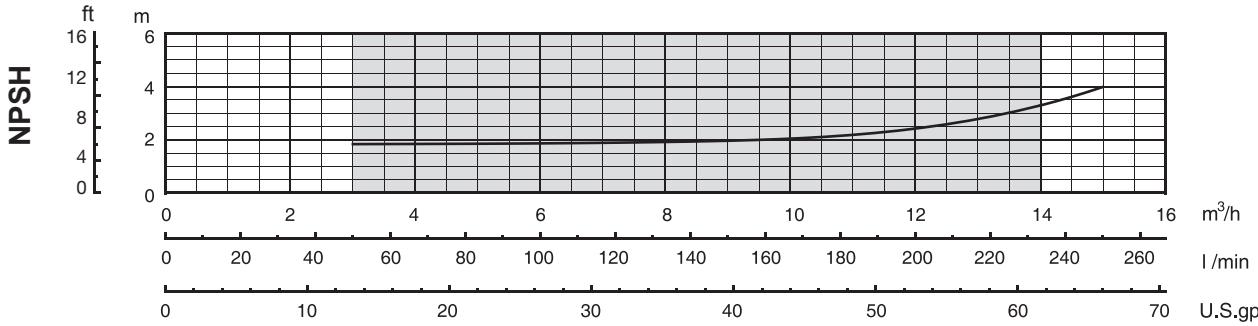
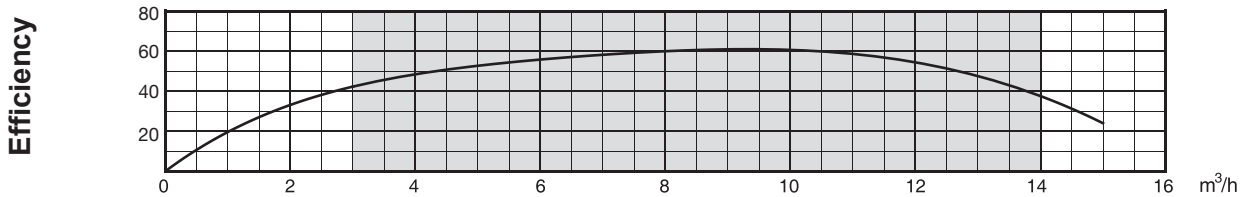
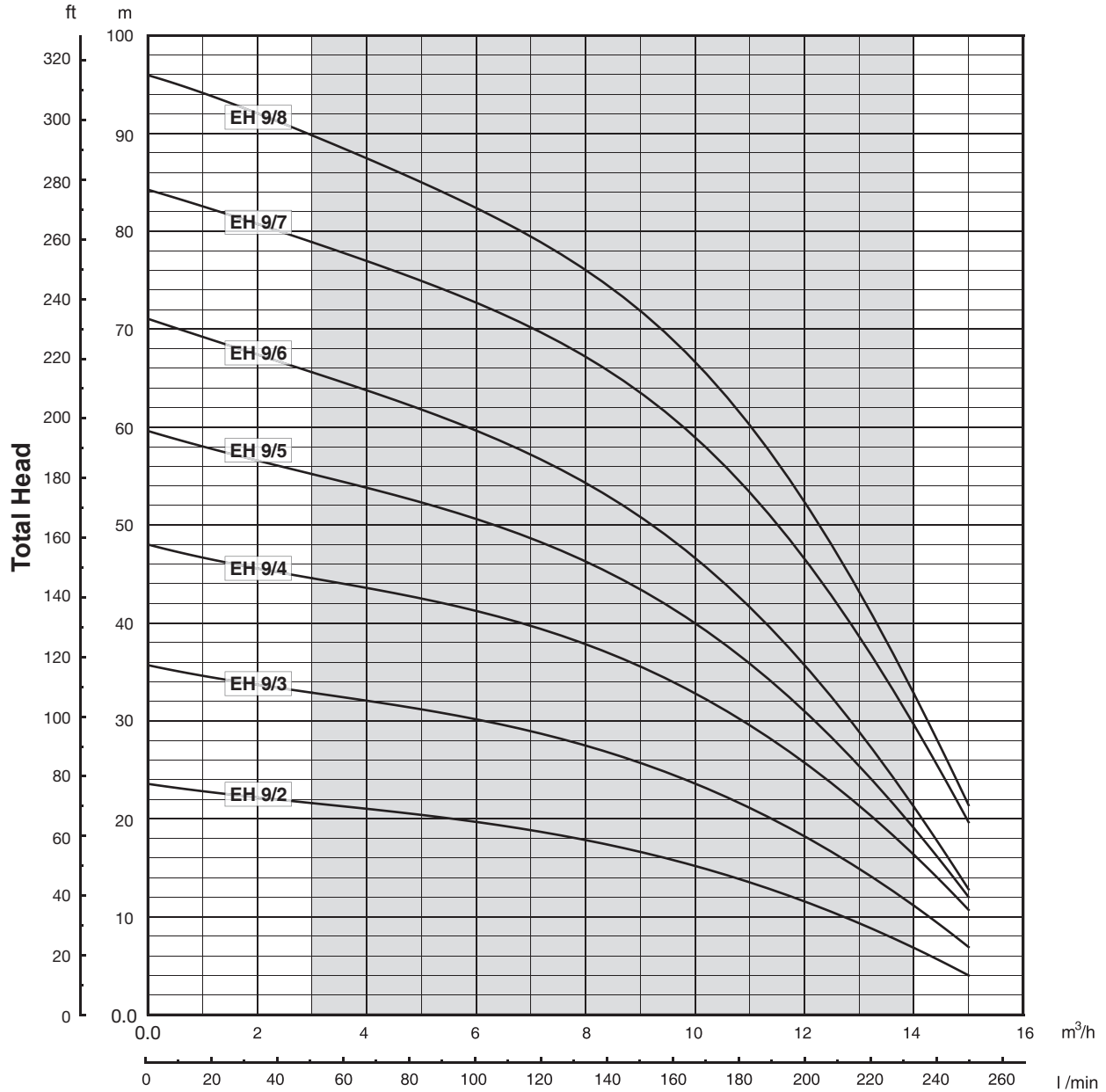

## Technical data 50Hz

Pumps model		NUMERO DI STADI	POTENZA		POTENZA ASSORBITA	CONDENSATORE INTERNO		CORRENTE NOMINALE		
Single-phase 220-240V 50Hz	Three-phase 380-415V 50Hz		kW	HP	kW	μF	V	Single-phase 220-240V 50Hz	Three-phase	
									220-240V 50Hz	380-415V 50Hz
-	<b>EH 15/2T</b>	2	1.5	2	1.71	-	-	-	5.7	3.3
-	<b>EH 15/3T</b>	3	2.2	3	2.55	-	-	-	8.3	4.8
-	<b>EH 15/4T</b>	4	3	4	3.38	-	-	-	11.4	6.6
-	<b>EH 15/5T</b>	5	4	5.5	4.22	-	-	-	13.2	7.6
-	<b>EH 15/6T</b>	6	5.5	7.5	5.13	-	-	-	15.2	8.8
-	<b>EH 15/7T</b>	7	5.5	7.5	5.91	-	-	-	17.0	9.8

■ Three-phase motors: 380-415 V ± 5 % / 50Hz. Thermal protection to be provide into the starter pale by the installer.

## Dimensions and weights

Pumps model		Dimensions															Weight (kg)		
Single-phase 220-240V 50Hz	Three-phase 380-415V 50Hz	A mm	E mm	F mm	G mm	DN1	DN2	ØB mm	H mm	H1 mm	L1 mm	L2 mm	L3 mm	M mm	N mm	N1 mm	1~ Single-phase	3~ Three-phase	
-	<b>EH 15/2T</b>	144	344	488	124	Rp 2"	Rp 1" 1/2	162	224	100	113,1	129,1	-	-	-	-	-	20	
-	<b>EH 15/3T</b>	144	388,5	532,5	131			179	231	100	113,1	172,6	-	-	-	-	-	-	24,5
-	<b>EH 15/4T</b>	192	388,5	580,5	131			179	231	100	113,1	172,6	-	-	-	-	-	-	28,5
-	<b>EH 15/5T</b>	240	397	637	146			194	246	100	150,2	-	279,2	170	160	192	-	-	35,5
-	<b>EH 15/6T</b>	288	412	700	151			218	263	112	151,7	-	328,7	180	190	220	-	-	47,5
-	<b>EH 15/7T</b>	336	412	748	151			218	263	112	151,7	-	376,7	180	190	220	-	-	48,5

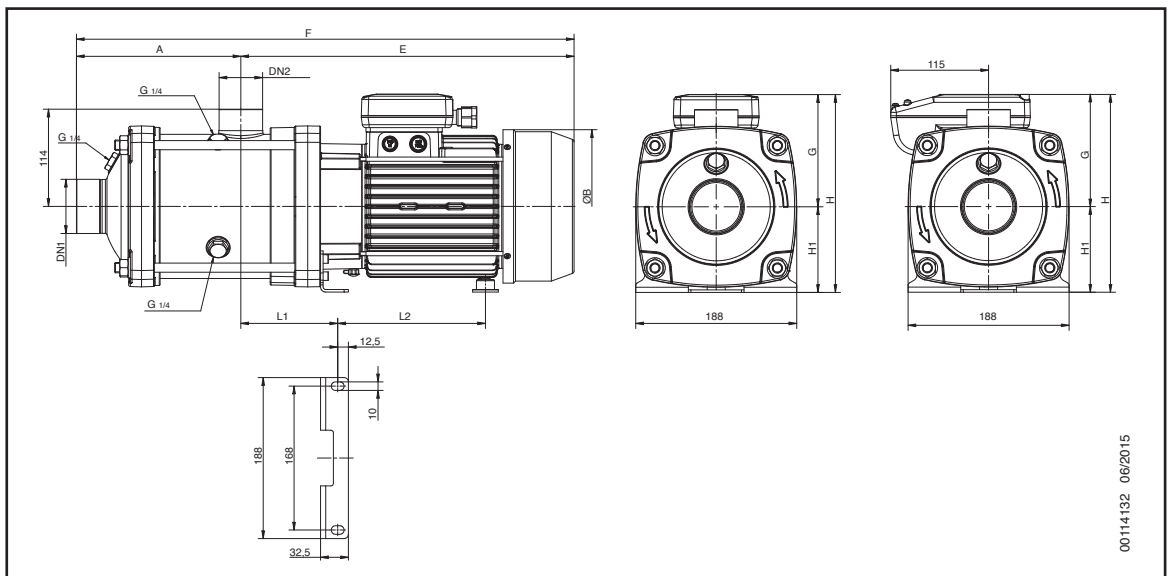

00114132 06/2015

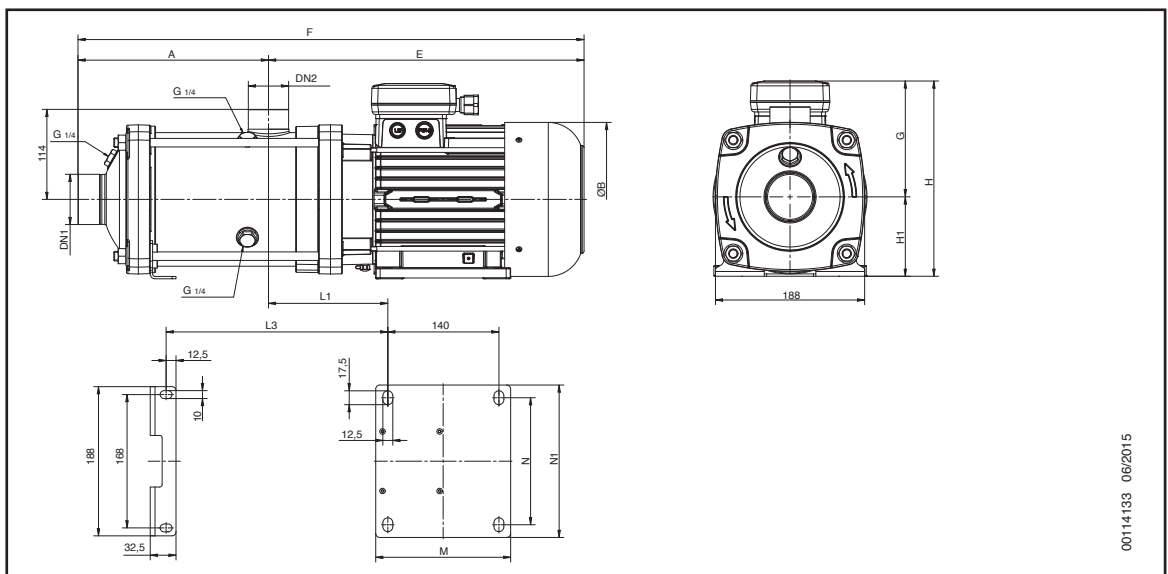

00114133 06/2015

## Performance curves 50Hz

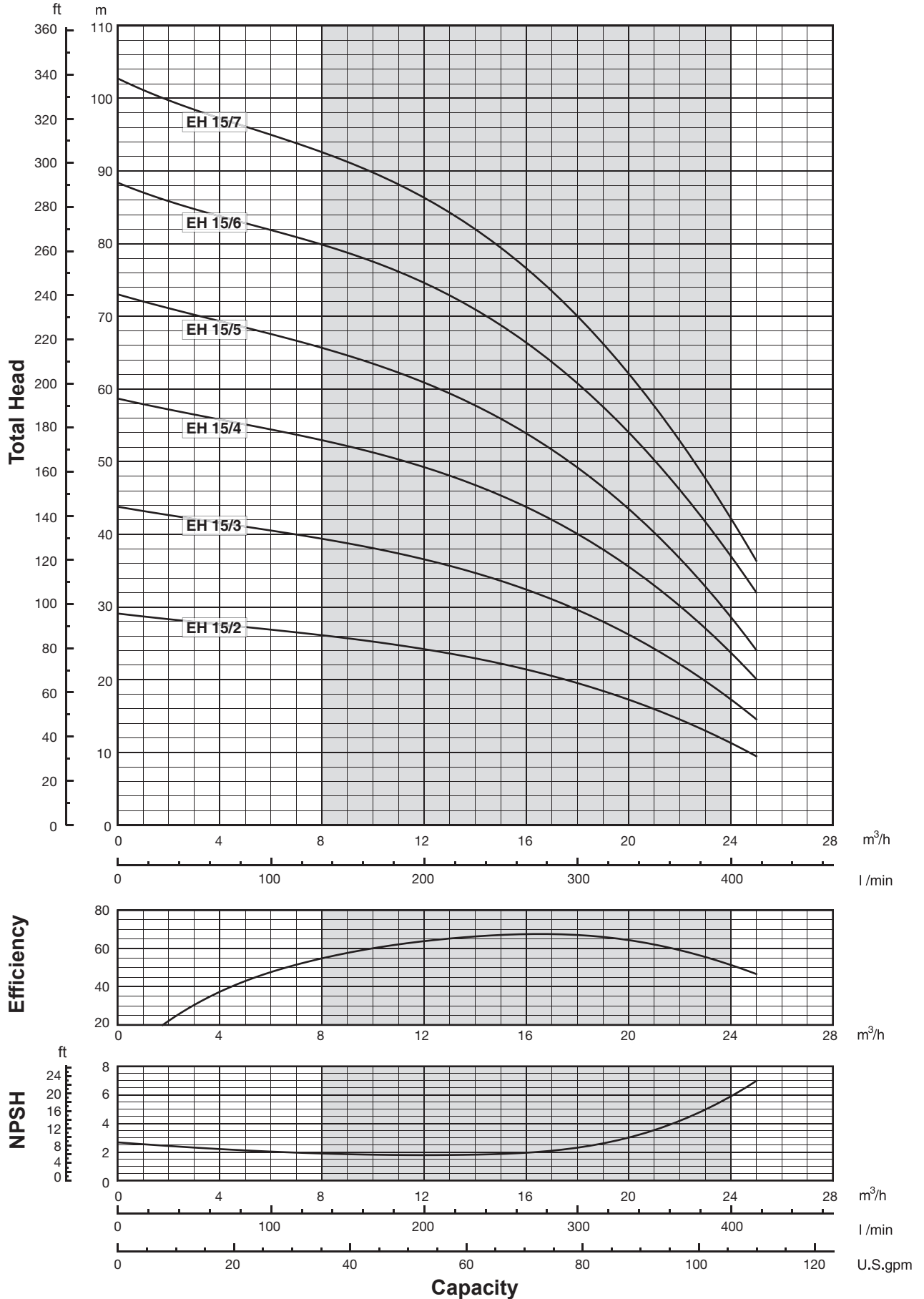

## Technical data 50Hz

Pumps model		NUMBER OF STAGES	POWER		INPUT POWER	INTERNAL CAPACITOR		RATED CURRENT		
Single-phase 220-240V 50Hz	Three-phase 380-415V 50Hz		kW	HP		kW	μF	V	Single-phase 220-240V 50Hz	Three-phase
				220-240V 50Hz	380-415V 50Hz					
-	EH 20/2T	2	2.2	3	2.35	-	-	-	8.0	4.6
-	EH 20/3T	3	3	4	3.46	-	-	-	11.6	6.7
-	EH 20/4T	4	4	5.5	4.57	-	-	-	14.0	8.1
-	EH 20/5T	5	5.5	7.5	5.79	-	-	-	16.6	9.6

- Three-phase motors: 380-415 V ± 5 % / 50Hz. Thermal protection to be provide into the starter pale by the installer.

## Dimensions and weights

Pumps model		Dimensions															Weight (kg)			
Single-phase 220-240V 50Hz	Three-phase 380-415V 50Hz	A mm	E mm	F mm	G mm	DN1	DN2	ØB mm	H mm	H1 mm	L1 mm	L2 mm	L3 mm	M mm	N mm	N1 mm	1~ Single-phase	3~ Three-phase		
-	EH 20/2T	144	388,5	532,5	131	Rp 2"	Rp 1" ½	179	231	100	113,1	172,6	-	-	-	-	-	-	24,5	
-	EH 20/3T	144	388,5	532,5	131			179	231	100	113,1	172,6	-	-	-	-	-	-	-	27,5
-	EH 20/4T	192	397	589	146			194	246	100	150,2	-	231,2	170	160	192	-	-	-	34,5
-	EH 20/5T	240	412	652	151			218	263	112	151,7	-	280,7	180	190	220	-	-	-	46

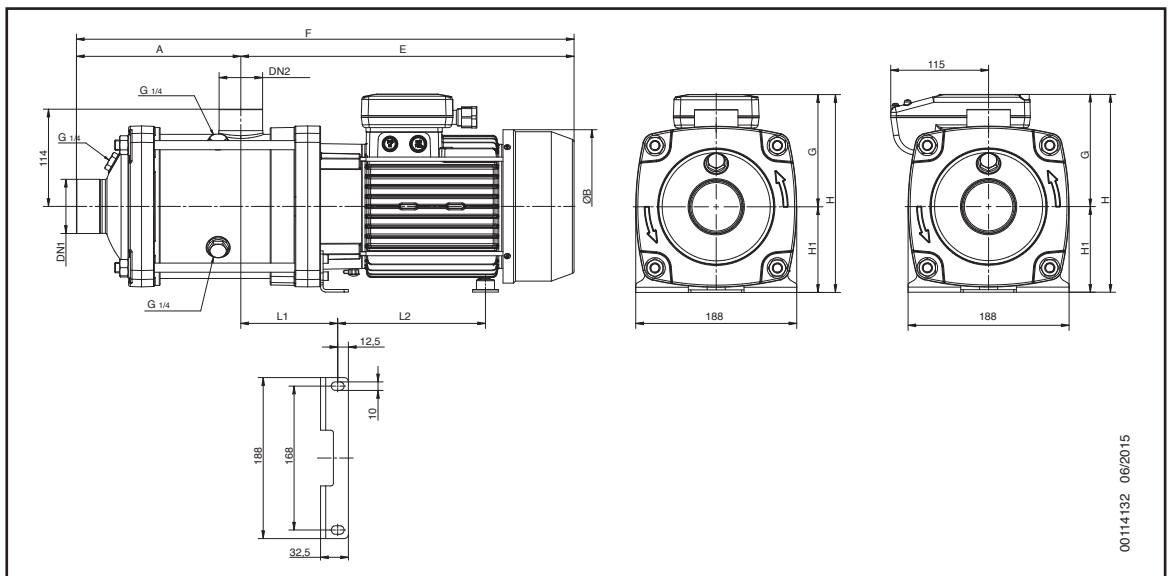

00114132 06/2015

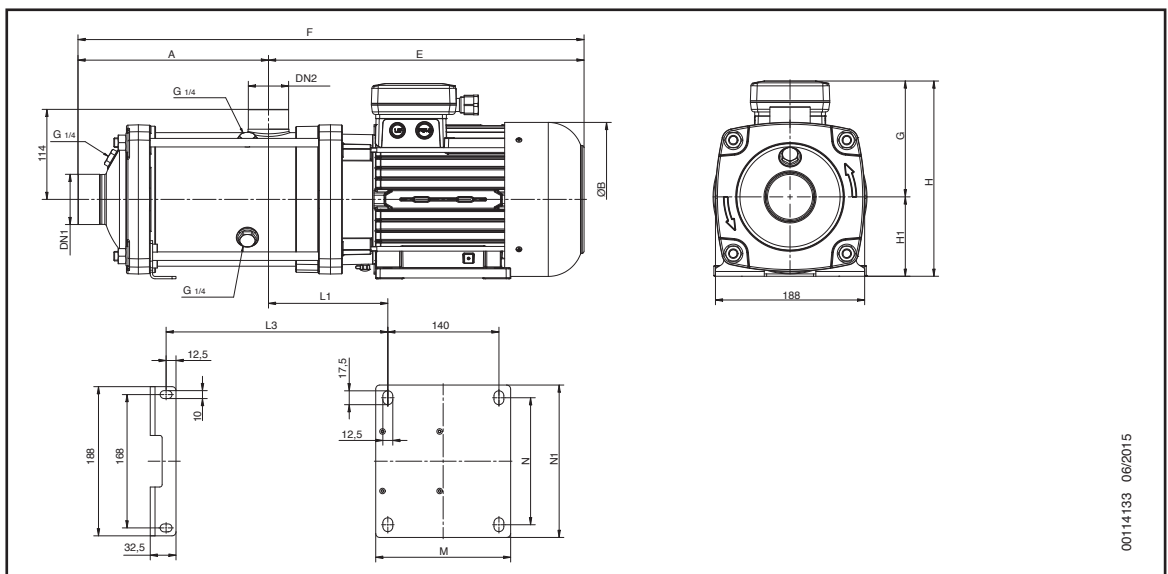

00114133 06/2015

## Performance curves 50Hz

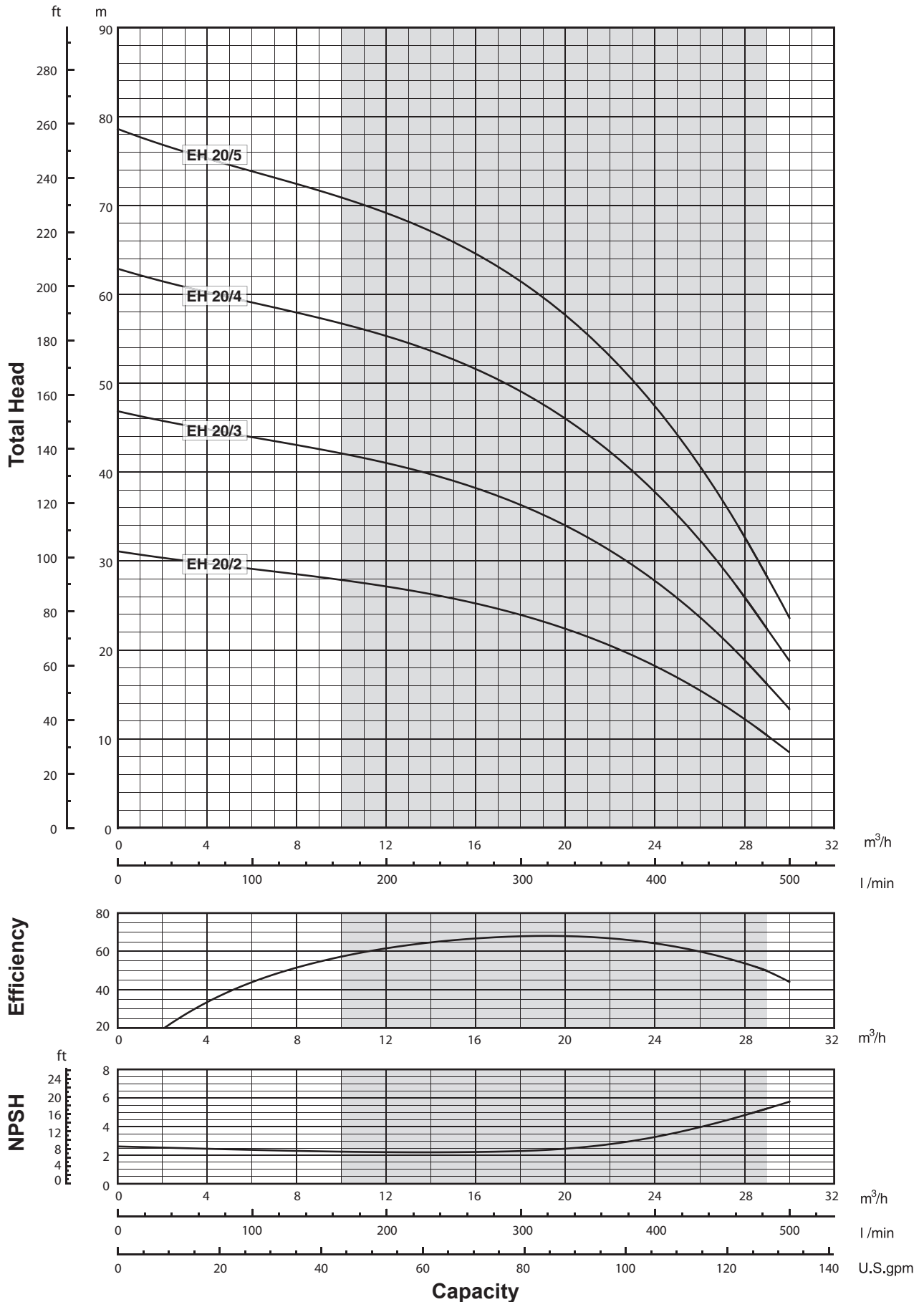

00114131\_09/2015





---

# **EH Series Pump Section and List of Main Components**

# EH Series pump section and List of Main components

## EH 3 - 5 - 9

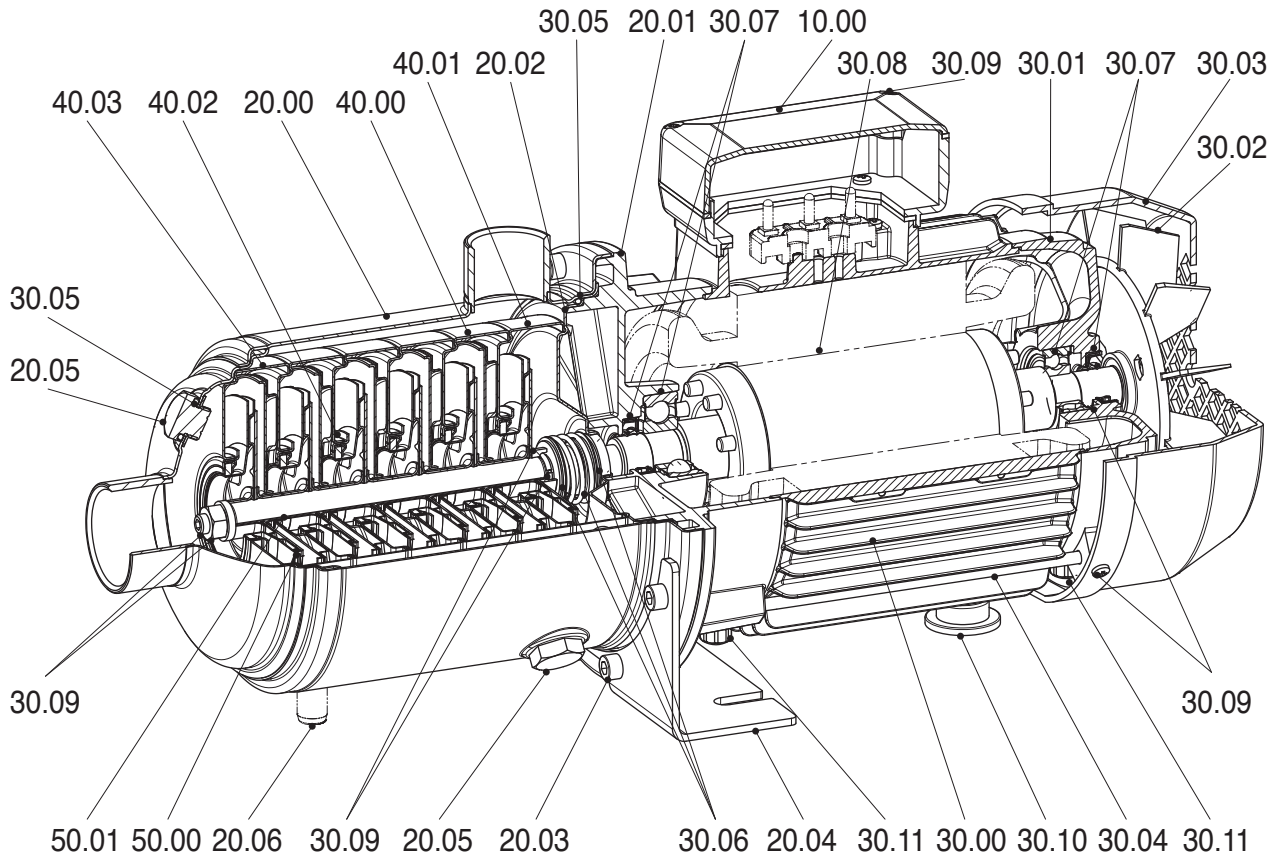

00114134 06/2015

Ref. N.	Description
10.00	Terminal box cover
20.00	Pump casing
20.01	Motor bracket
20.02	Seal housing
20.03	Screws for pump casing
20.04	Support foot
20.05	Filling and draining plugs
20.06	Pump casing foot
30.00	Motor housing and stator
30.01	Bearing housing
30.02	Fan
30.03	Fan cover
30.04	Motor tie rod

Ref. N.	Description
30.05	O-Rings
30.06	Mechanical seals
30.07	Ball bearings and lip seal
30.08	Rotor and pump shaft
30.09	Screws, nuts and washers
30.10	Motor foot
30.11	Valve plug
40.00	Stage housing and diffuser
40.01	Last stage with holes
40.02	Floating neck ring assembly
40.03	Initial stage housing
50.00	Impeller
50.01	Impeller spacers

# EH Series pump section and List of Main components

## EH 15 - 20

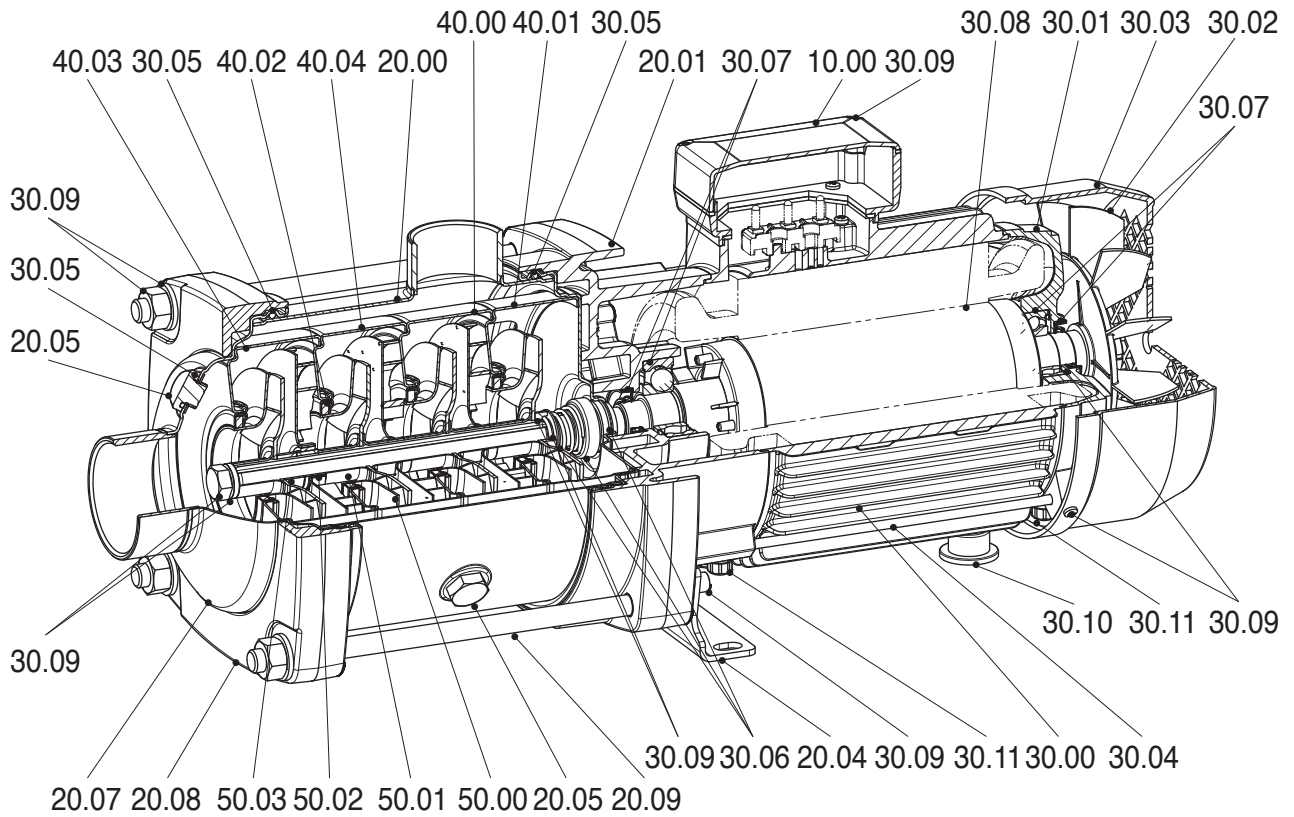

(Configuration up to 3kW)

Ref. N.	Description
10.00	Terminal box cover
20.00	Pump casing
20.01	Motor bracket
20.02	Seal housing
20.04	Impeller spacers
20.05	Filling and draining plugs
20.07	Inlet cover
20.08	Flange
20.09	Pump casing tie rods
30.00	Motor housing and stator
30.01	Bearing housing
30.02	Fan
30.03	Fan cover
30.04	Motor tie rod
30.05	O-Rings

Ref. N.	Description
30.06	Mechanical seals
30.07	Ball bearings and lip seal
30.08	Rotor and pump shaft
30.09	Screws, nuts and washers
30.10	Motor foot
30.11	Valve plug
40.00	Stage housing and diffuser
40.01	Last stage with holes
40.02	Floating neck ring assembly
40.03	Initial stage housing
40.04	Stage housing and diffuser with bearing
50.00	Impeller
50.01	Impeller spacers
50.02	Intermediary sleeve
50.03	Intermediary sleeve spacer

00114195 06/2015

# EH Series pump section and List of Main components

## EH 15 - 20

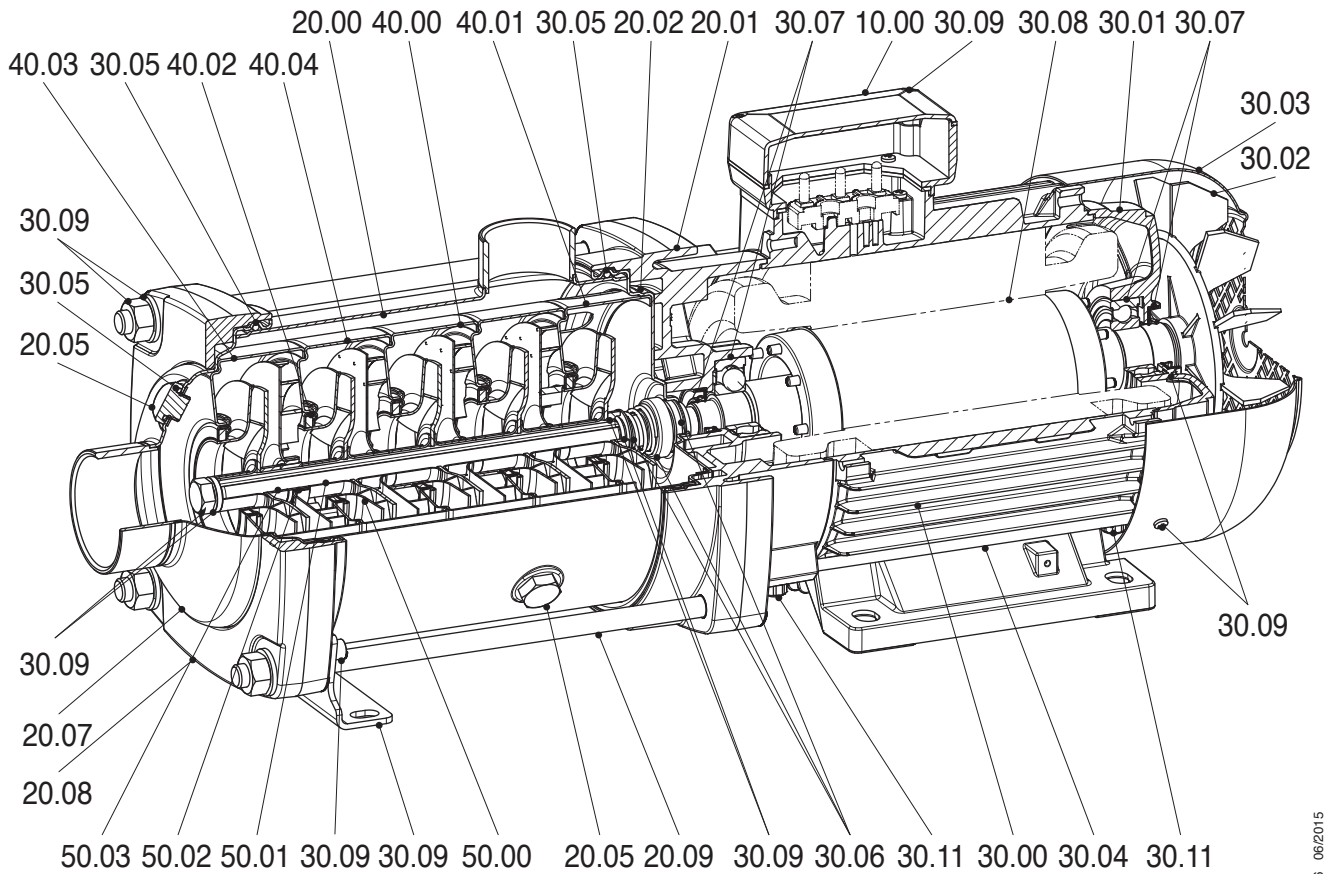

00114136 06/2015

(Configuration from 4kW)

Ref. N.	Description
10.00	Terminal box cover
20.00	Pump casing
20.01	Motor bracket
20.02	Seal housing
20.04	Support foot
20.05	Filling and draining plugs
20.07	Inlet cover
20.08	Flange
20.09	Flange
30.00	Motor housing and stator
30.01	Bearing housing
30.02	Fan
30.03	Fan cover
30.04	Motor tie rod
30.05	O-Rings

Ref. N.	Description
30.06	Mechanical seals
30.07	Ball bearings and lip seal
30.08	Rotor and pump shaft
30.09	Screws, nuts and washers
30.10	Motor foot
30.11	Valve plug
40.00	Stage housing and diffuser
40.01	Last stage with holes
40.02	Floating neck ring assembly
40.03	Initial stage housing
40.04	Stage housing and diffuser with bearing
50.00	Impeller
50.01	Impeller spacers
50.02	Impeller spacers
50.03	Intermediary sleeve spacer



**Vertical S.r.l.**  
**via Asolo, 7**  
**36031 Dueville (Vicenza) - Italia**  
**Tel. +39 0444 361114**  
**Fax +39 0444 365247**  
**P.IVA e C.F. 00558130241**  
**e-mail: [sales@vertical.vi.it](mailto:sales@vertical.vi.it)**  
**[www.etechpumps.com](http://www.etechpumps.com)**

*Unipersonale – Società sotto la direzione  
e il controllo di Franklin Electric Co., Inc.*