

Intrinsically safe pressure transmitter For applications in hazardous areas Models IS-20-S, IS-21-S, IS-20-F, IS-21-F

WIKA data sheet PE 81.50



further approvals
see page 6

Applications

- Chemical, petrochemical industry
- Oil, natural gas
- Machine building

Special features

- Measuring ranges from 0 ... 0.1 to 0 ... 1,000 bar
- Approved for use in hazardous areas per ATEX, FM and CSA
- Suitable for SIL 2 per IEC 61508/IEC 61511



Fig. left: Pressure transmitter model IS-21-S

Fig. right: Pressure transmitter model IS-20-F

Description

For the highest demands

The intrinsically safe pressure transmitters of the IS-2x series are ideally suited to applications in hazardous areas. These pressure transmitters have been specifically designed for the highest industrial requirements and feature the relevant worldwide approvals of ATEX, FM, CSA and a SIL rating.

Design

All wetted parts are manufactured from stainless steel and are fully welded. Internal sealing elements are completely avoided, so that the unit can be used with all media. The robust case is also made of stainless steel and provides a minimum ingress protection of IP 65. IP 68 versions are also available.

The IS-21-x models are particularly suitable for the measurement of viscous or contaminated media. Due to the flush diaphragm of the process connection, trouble-free pressure measurement is ensured at all times.

The field case of the model IS-2x-F enables operation in extreme environmental conditions and is resistant to acids, bases, oils and solvents. Via the field case connection integrated into the case's head, the electrical cabling can be installed quickly and easily.

Voltage supply

It is recommended that the pressure transmitter is powered via a suitable Ex isolated barrier. An ideal voltage supply is offered by the model KFD2-STC4-EX1 isolated barrier, see "Accessories".

Measuring ranges

Relative pressure in bar							
Measuring range	0 ... 0.1	0 ... 0.16	0 ... 0.25	0 ... 0.4	0 ... 0.6	0 ... 1	0 ... 1.6
Overpressure limit	1.4	1.4	1.4	4.1	4.1	4.1	8.3
Measuring range	0 ... 2.5	0 ... 4	0 ... 6	0 ... 10	0 ... 16	0 ... 25	0 ... 40
Overpressure limit	8.3	19.3	41.4	41.4	82.8	82.8	80
Measuring range	0 ... 60	0 ... 100	0 ... 160	0 ... 250	0 ... 400	0 ... 600	0 ... 1,000 ¹⁾
Overpressure limit	120	200	320	500	800	1,200	1,500

1) Only available for model IS-20

Absolute pressure in bar							
Measuring range	0 ... 0.25	0.8 ... 1.2	0 ... 0.4	0 ... 0.6	0 ... 1	0 ... 1.6	0 ... 2.5
Overpressure limit	1.4	4.1	4.1	4.1	4.1	8.3	8.3
Measuring range	0 ... 4	0 ... 6	0 ... 10	0 ... 16	0 ... 25		
Overpressure limit	19.3	41.4	41.4	82.8	82.8		

Vacuum and +/- measuring ranges in bar							
Measuring range	-1 ... 0	-1 ... +0.6	-1 ... +1.5	-1 ... +3	-1 ... +5	-1 ... +9	-1 ... +15
Overpressure limit	4.1	8.3	8.3	19.3	41.4	41.4	82.8
Measuring range	-1 ... +24						
Overpressure limit	82.8						

Other measuring ranges on request

Output signal

Analogue signal

4 ... 20 mA

Permissible load in Ω

■ Model IS-2x-S

$\leq (\text{power supply} - 10 \text{ V}) / 0.02 \text{ A} - (\text{cable length in m} \times 0.14 \Omega)$

■ Model IS-2x-F

$\leq (\text{power supply} - 11 \text{ V}) / 0.02 \text{ A}$

For the test circuit signal of the IS-2x-F models a load of $\leq 15 \Omega$ applies

Voltage supply

Power supply U_+

Model IS-2x-S: DC 10 ... 30 V

Model IS-2x-F: DC 11 ... 30 V

Power consumption P_i

1 W (750 mW with approval for category 1D)

Reference conditions (per IEC 61298-1)

Temperature

15 ... 25 °C

Atmospheric pressure

860 ... 1,060 mbar

Humidity

45 ... 75 % r. h., non-condensing

Mounting position

Calibrated in vertical mounting position with process connection facing downwards.

Power supply

DC 24 V

Time response

Settling time

$\leq 2 \text{ ms}$

$\leq 10 \text{ ms}$, for medium temperatures below -30 °C

Accuracy data

Accuracy at reference conditions

Accuracy	
Standard	0.50 % of span
Option	0.25 % of span ¹⁾

¹⁾ Only for measuring ranges ≥ 0.25 bar

Including non-linearity, hysteresis, zero offset and end value deviation (corresponds to measured error per IEC 61298-2).

Non-linearity (IEC 61298-2)

≤ 0.2 % of span BFSL

Non-repeatability

≤ 0.1 % of span

Mean temperature coefficient of zero point

Measuring range ≤ 0.25 bar: ≤ 0.4 % of span/10 K

Measuring range > 0.25 bar: ≤ 0.2 % of span/10 K

Mean temperature coefficient of span

≤ 0.2 % of span/10 K

Long-term stability at reference conditions

$\leq \pm 0.2$ % of span/year

Adjustability of zero point and span

Adjustment is made using potentiometers inside the instrument.

Zero point: ± 5 %

Span: ± 5 %

Operating conditions

Ingress protection (per IEC 60529)

The ingress protection depends on the respective electrical connection.

- Angular connector DIN 175301-803 A: IP 65
- Circular connector M12 x 1: IP 67
- Cable outlet, IP 67: IP 67
- Cable outlet, IP 68: IP 68 ¹⁾
- Bayonet connector: IP 67
- Field case: IP 67

¹⁾ 72 h / 300 mbar

Vibration resistance

(in accordance with IEC 60068-2-6, vibration under resonance)

Model IS-2x-S: 20 g

Model IS-2x-F: 10 g

Shock resistance

(per IEC 60068-2-27, mechanical shock)

Model IS-2x-S: 1,000 g

Model IS-2x-F: 600 g

Permissible temperature ranges

- Medium: see diagramm (page 3) and table (page 4)
- Ambient: see diagramm (page 3) and table (page 4)
- Storage: $-30 \dots +105$ °C

Permissible temperature ranges for process connections with cooling element

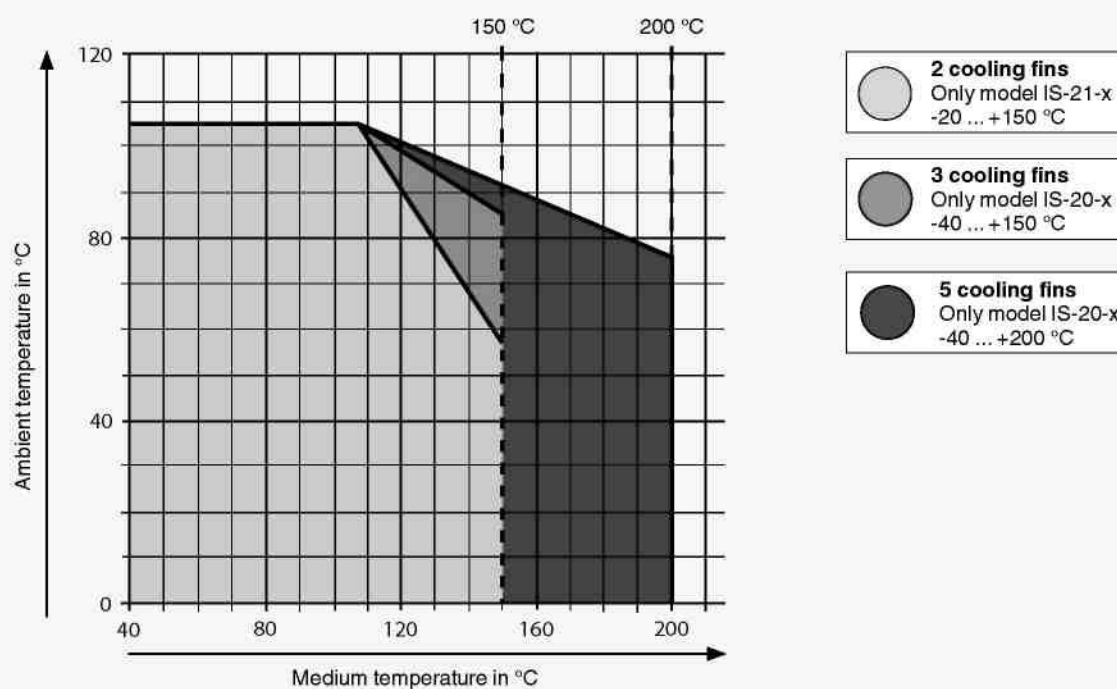

Permissible ambient and medium temperatures ¹⁾

Electrical connection	Category		Ignition protection type	Permissible ambient and medium temperatures
	Group II	Group I		
Angular connector DIN 175301-803 A	1/2 G		Ex ia IIC T4/T5/T6	-20 ... +60 °C (T6) -20 ... +80 °C (T5) -20 ... +80 °C (T4)
		M1	Ex ia I	-20 ... +80 °C
Circular connector M12 x 1	1/2 G		Ex ia IIC T4/T5/T6	-20 ... +60 °C (T6) -20 ... +80 °C (T5) -20 ... +80 °C (T4)
		M1	Ex ia I	-20 ... +80 °C
Cable outlet IP 67	1/2 G		Ex ia IIC T4/T5/T6	-20 ... +60 °C (T6) -20 ... +80 °C (T5) -20 ... +80 °C (T4)
		M1	Ex ia I	-20 ... +60 °C
Bayonet connector	1/2 G		Ex ia IIC T4/T5/T6	-20 ... +60 °C (T6) -20 ... +80 °C (T5) -20 ... +80 °C (T4)
Cable outlet IP 68	1/2 G		Ex ia IIC T4/T5/T6	-20 ... +60 °C (T6) -20 ... +80 °C (T5) -20 ... +80 °C (T4)
		M1	Ex ia I	-20 ... +80 °C
Field case, model IS-2x-F	1/2 G		Ex ia IIC T4/T5/T6	-20 ... +60 °C (T6) -20 ... +80 °C (T5) -20 ... +80 °C (T4)
		M1	Ex ia I	-20 ... +80 °C (T4)
Cable outlet IP 68, PUR	1G		Ex ia IIA T4/T5/T6	-10 ... +60 °C (T6) -10 ... +60 °C (T5) -10 ... +60 °C (T4)
	1/2 G		Ex ia IIC T4/T5/T6	-10 ... +60 °C (T6) -10 ... +60 °C (T5) -10 ... +60 °C (T4)
	1D		Ex iaD 20 IP 65 T80 °C Ex iaD 20 IP 65 T100 °C	-10 ... +40 °C -10 ... +60 °C
		M1	Ex ia I	-10 ... +60 °C
Cable outlet IP 68, FEP	1G		Ex ia IIA T4/T5/T6	-20 ... +60 °C (T6) -20 ... +80 °C (T5) -20 ... +80 °C (T4)
	1/2 G		Ex ia IIC T4/T5/T6	-20 ... +60 °C (T6) -20 ... +80 °C (T5) -20 ... +80 °C (T4)
	1D		Ex iaD 20 IP 65 T80 °C Ex iaD 20 IP 65 T100 °C	-20 ... +40 °C -20 ... +60 °C
		M1	Ex ia I	-20 ... +80 °C

1) For instruments with a flush process connection and a measuring range of 0 ... 400 or 0 ... 600 bar, the medium temperature is limited to -30 ... +70 °C.

Electrical connections

Reverse polarity protection

U₊ vs. U₋

Insulation voltage

AC 500 V

Connection diagrams

Angular connector DIN 175301-803 A



U ₊	1
U ₋	2

Circular connector M12 x 1



U ₊	1
U ₋	3

Bayonet connector

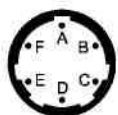

U ₊	A
U ₋	B

Cable outlet

	PUR cable	FEP cable
U ₊	brown	brown
U ₋	green	green
Shield	grey	grey

Field case

U ₊	1
U ₋	2
Test+	3
Test-	4
Shield	5



Process connections

Process connections without cooling element

Model IS-20-x	Standard	Thread size
EN 837		G ¼ B
		G ½ B
DIN 3852-E		G ¼ A
		G ½ A
DIN 16288		M20 x 1.5
ANSI/ASME B1.20.1		¼ NPT
		½ NPT

Model IS-21-x

Standard	Thread size
-	G ½ B flush
	G 1 B flush
Hygienic	G 1 B flush

Process connections with cooling element

Model IS-20-x	Standard	Thread size
EN 837		G ½ B with 3 cooling fins
		G ½ B with 5 cooling fins

Model IS-21-x

Standard	Thread size
-	G ½ B flush with 2 cooling fins

Sealings

Process connection	Standard	Option
EN 837	Copper	Stainless steel
G ½ B flush	NBR ¹⁾	FKM ²⁾
G 1 B flush	NBR ¹⁾	FKM ²⁾
Hygienic	EPDM	-

1) Permissible temperature range: -20 ... +100

2) Permissible temperature range: -15 ... +200

The sealings listed under "Standard" are included in the delivery.

Materials

Wetted parts

- Stainless steel
- For sealing materials see "Process connections"

Non-wetted parts

- Stainless steel
- Internal transmission medium
 - No oxygen application: Synthetic oil
 - Oxygen application: Halocarbon oil
 - Model IS-20-x > 25 bar: Dry measuring cell

CE conformity

Pressure equipment directive

97/23/EC

EMC directive

2004/108/EC, EN 61326 emission (group 1, class B) and interference immunity (industrial application)

ATEX directive

94/9/EC

RoHS conformity

Directive 2011/65/EU

Approvals

- **FM**, IS/I, II, III/1/ABCDEFGH/T*; -2323880; Entity; IP 65
I/0/AEx ia IIC T*; -2323880; Entity; IP 65
NI/I, II, III/2/ABCDEFGH/T* -2323880; NI Field wiring IP 65
I / 2 / IIC / T*, -2323880; NI Field wiring IP 65
T* = T4 at 105 °C, T5 at 80 °C, T6 at 60 °C, USA
- **CSA**, class I, groups A, B, C and D; class II, groups E, F and G; class III
Canadian zone designation: Class I, zone 0, group IIC; Ex ia; IP65; DIP A20;
US zone designation: Class I, zone 0, zone 20, group IIC; AEx ia; IP 65, Canada
- **GOST-R**, import certificate, Russia
- **GOST**, metrology/measurement technology, Russia
- **SIL**, functional safety
- **GL**, ships, shipbuilding (e.g. offshore), Germany
- **CRN**, safety (e.g. electr. safety, overpressure, ...), Canada

Certificates (option)

- 3-A conformity of the diaphragm seal, based on a third party verification, in accordance with 3-A standard 74-05

Approvals and certificates, see website

Dimensions in mm

Pressure transmitter

Angular connector DIN
175301-803 A

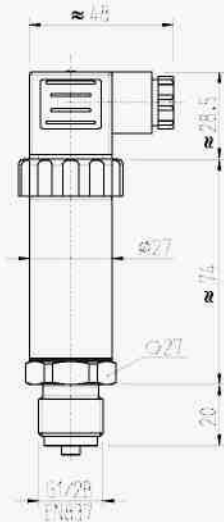

Weight: approx. 200 g

Circular connector M12 x 1

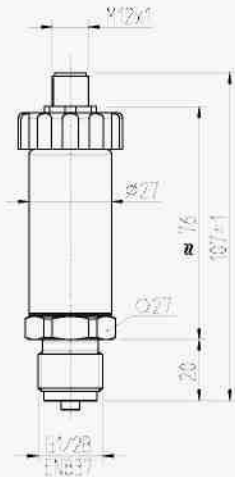

Weight: approx. 200 g

Bayonet connector

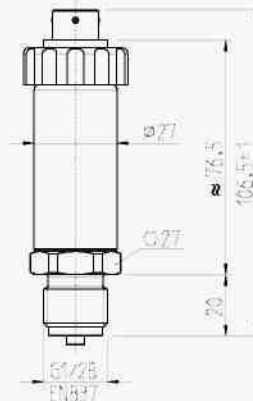

Weight: approx. 200 g

Cable outlet IP 67

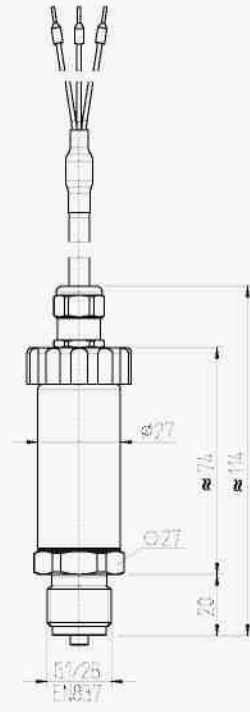

Weight: approx. 200 g

Cable outlet IP 68

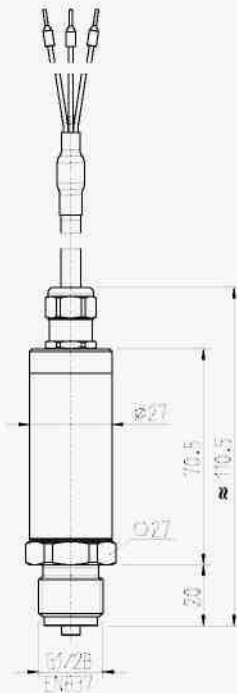

Weight: approx. 200 g

Cable outlet IP 68

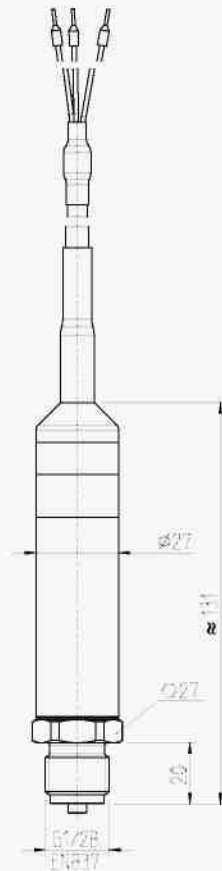

Weight: approx. 200 g

Field case, model IS-2x-F

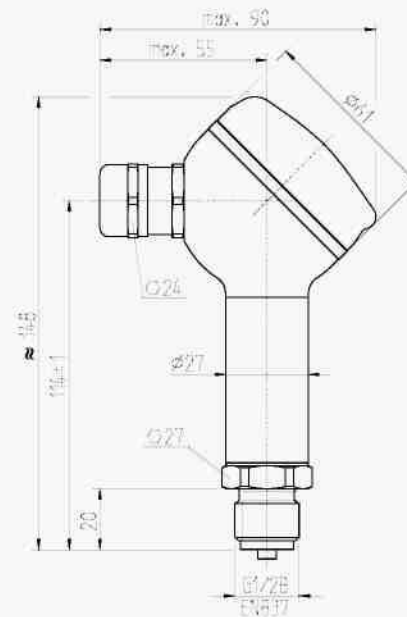

Weight: approx. 350 g

Process connections for model IS-20-x

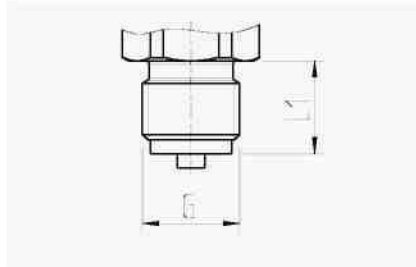

G	L1
G 1/4 B EN 837	13
G 1/2 B EN 837	20

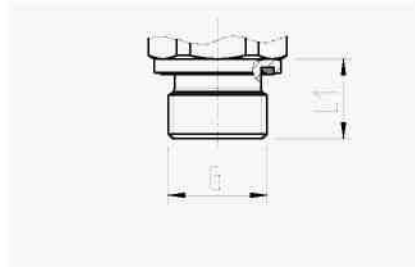

G	L1
G 1/4 A DIN 3852-E	14
G 1/2 A DIN 3852-E	17

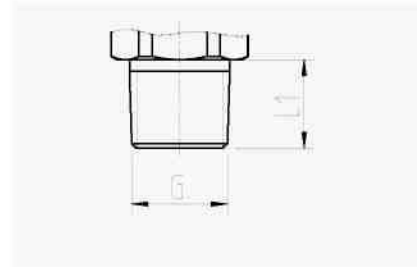

G	L1
1/4 NPT	13
1/2 NPT	19

Process connections for model IS-21-x

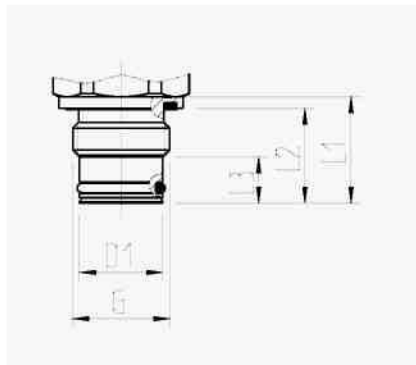

G	L1	L2	L3	D1
G 1/2 B	23	20.5	10	18

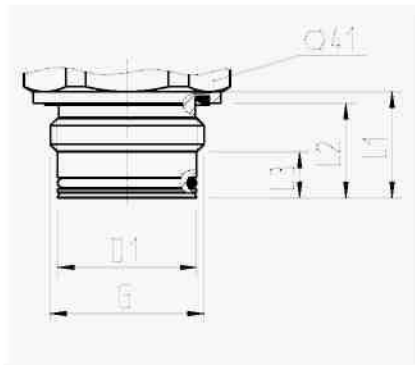

G	L1	L2	L3	D1
G 1 B	23	20.5	10	30

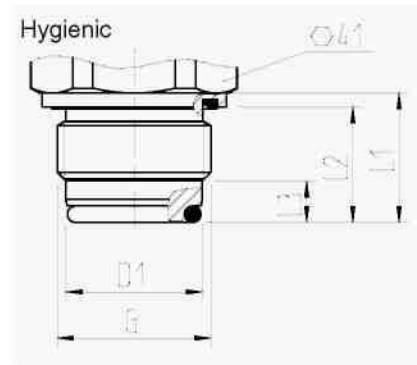

G	L1	L2	L3	D1
G 1 B	28	25	9	29.5

Process connections with cooling element for model IS-2x

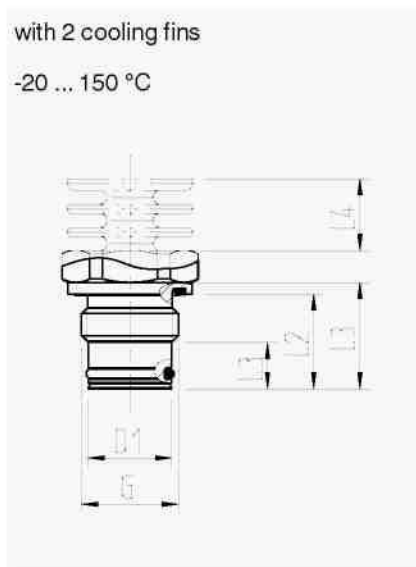

G	L1	L2	L3	L4	D1
G 1/2 B	23	20.5	10	15.5	18

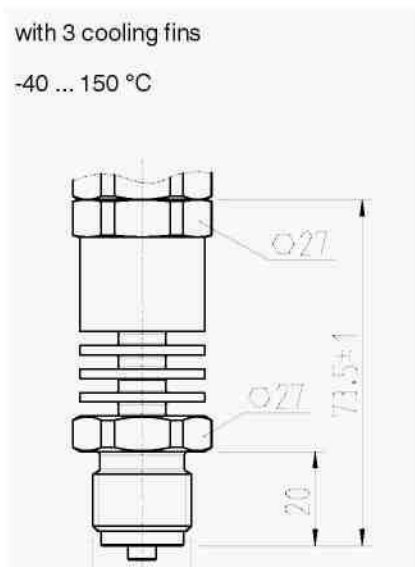

G	L1	L2	L3	L4	D1
G 1/2 B EN 837	23	20.5	10	15.5	18

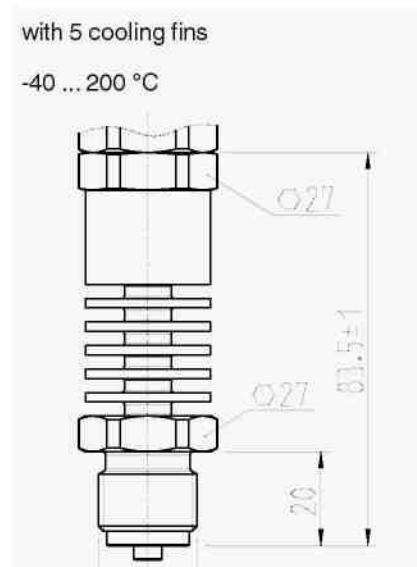

G	L1	L2	L3	L4	D1
G 1/2 B EN 837	23	20.5	10	15.5	18

For information on tapped holes and welding sockets, see Technical information IN 00.14 at www.wika.com.

Accessories and spare parts

Sealings for mating connectors

Description	Order no.	
	Blue (Wika)	Brown (neutral)
Angular connector DIN 175301-803 A	1576240	11437902

Sealings for process connection

Process connection	Order no.			
	Copper	Stainless steel	NBR	FKM
G ¼ B EN 837	11250810	11250844	-	-
G ½ B EN 837	11250861	11251042	-	-
M20 x 1.5 DIN 16288	11250861	11251042		
G ¼ A DIN 3852-E	-	-	1537857	1576534
G ½ A DIN 3852-E	-	-	1039067	1039075

Isolated barrier

Description	Order no.
Isolated barrier KFD2-STC4-Ex1	2341268

Ordering information

Model / Measuring range / Output signal / Power supply / Non-linearity / Temperature range / Process connection / Sealing / Electrical connection / Certificates

© 2011 WIKA Alexander Wiegand SE & Co. KG, all rights reserved.
The specifications given in this document represent the state of engineering at the time of publishing.
We reserve the right to make modifications to the specifications and materials.

ООО ТД «АЗТЭО»
624260, Россия Свердловская область,
г. Асбест, пр. Ленина, 8/3
Тел: 8 (34365) 2-87-74, 2-45-52
Факс: 8 (34365) 2-87-74
E-mail: zakaz@azteo.ru