

Differential Pressure Transmitter Model DPT-10

WIKA Data Sheet PE 86.21



Applications

- Process engineering
- Pharmaceutical
- Food and beverage industries

Special features

- High measuring accuracy
- Scaleable measuring ranges
- Various hazardous area approvals
- Seven different housing variants
- Configuration via DTM (Device Type Manager) according to FDT (Field Device Tool) - concept (e.g. PACTware)



Differential Pressure Transmitter Model DPT-10

Description

With its 4 ... 20 mA, 4 ... 20 mA HART®, PROFIBUS® PA or FOUNDATION Fieldbus™ output signals, combined with either intrinsically-safe or flameproof ignition protection (in accordance with ATEX), the DPT-10 is ideally suited to applications requiring these features. The electronics of all of these transmitters, even for the flameproof variant, are intrinsically safe. Thus it is possible to make adjustments on the instrument in EX areas while the instrument is live.

Versatile in application

The DPT-10 is suitable for many industrial measuring requirements, such as flow measurement using differential pressure transducers, level measurement or filter and pump monitoring. With diaphragm seals fitted, the DPT-10 is also suitable for harsh process conditions. As a result of the available measuring ranges of 0 ... 10 mbar up to 0 ... 40 bar and a static pressure limitation of up to 420 bar, the instrument can be used in almost any application. The internal digital signal processing, combined with proven sensors, guarantees high accuracy and the best long-term stability.

There are seven different housing variants available, and thus, it is possible to select a variant suited to every operating environment. The housing itself can be rotated through 330°, and is available in plastic, aluminium and stainless steel. An electropolished stainless steel housing (316 L) is available to meet the high demands of the food industry and pharmaceutical industry.

Easy configuration and operation

Service and configuration at the instrument is carried out using the optional display and operation module, which can be fitted in four positions. The operation menu has a simple and self-explanatory structure and has seven selectable languages as standard. Alternatively, the operating parameters can be set using the PACTware™ free and non-proprietary configuration software. An instrument-specific DTM enables easy integration into a corresponding Distributed Control Systems.

Specifications		Model DPT-10						
Measuring range ¹⁾	bar	0.01	0.03	0.1	0.5	3	16	40 ²⁾
Max. static working pressure	bar	160	160	160	160 {420}	160 {420}	160 {420}	160 {420}
Smallest possible span	mbar	0.25	0.3	1	5	30	160	400
Lowest static pressure ³⁾	mbar abs	0.1						
Overload on one side	bar	160			160 {420}			
Overload on both sides	bar	240			240 {630}			

Accuracy			
Measuring ranges	bar	< 0.5	≥ 0.5
Long-term stability	% URL/Year	± 0.18	
Reference accuracy ⁴⁾	% of the span	Measuring ranges 10, 30 mbar: from TD 1:1 ± 0.15 % x TD 100 mbar: up to TD 4:1 ± 0.075 % from TD 4:1 ± (0.012 x TD + 0.027) %	up to TD 15:1 ± 0.075 % TD from 15:1 ± (0.0015 x TD + 0.053) %
Total Performance ^{5) 6)}		± 0.15 %	
Influence of the system pressure ⁶⁾			
Zero point	% URL	± 0.35 / 70 bar Measuring range 10 mbar: 0.15 / 7 bar	± 0.075 / 70 bar
Span	% URL	± 0.14 / 70 bar Measuring range 10 mbar: 0.035 / 7 bar	± 0.14 / 70 bar
Influence of the media and ambient temperature ⁶⁾			
-10 ... +60 °C		10 mbar and 30 mbar ± (0.31 x TD + 0.06) % 100 mbar ± (0.18 x TD + 0.06) %	0.5 bar, 3 bar, 40 bar ± (0.08 x TD + 0.05) % 16 bar ± (0.1 x TD + 0.1) %
-40 ... -10 / +60 ... +85 °C		10 mbar and 30 mbar ± (0.45 x TD + 0.1) % 100 mbar ± (0.3 x TD + 0.15) %	0.5 bar, 3 bar ± (0.12 x TD + 0.1) % 16 bar ± (0.15 x TD + 0.2) % 40 bar ± (0.37 x TD + 0.1) %
Mounting position influence	mbar	≤ 4	

Permitted temperature ranges			
Ambient ⁷⁾	°C	-40 ... +80 (without Display)	-20 ... +70 (with Display)
Transport/Storage		-40 ... +80	
Process limits dependent upon the sealing material ⁷⁾	°C	FKM/NBR: -20 ... +85 PTFE, copper: -40 ... +85 FKM, free of oil and grease: -10 ... +85	
for oxygen applications		Copper, PTFE: -20 ... +60; FKM: -10 ... +60	
Temperature limits	°C	With differential pressure lines longer than 100 mm: -40 ... +120 (-10 ... +120 with lateral flanges C22.8)	

Material		
Wetted parts		Process connection C22.8, {316L, C276} Diaphragm: 316L, C276, {Tantalum, C276 Gold-Rhodium coated, Monel400®} Seals: FKM/FPM, NBR, copper, {PTFE}
Internal transmission fluid ⁸⁾		Silicone oil (halocarbon oil for oxygen applications)
Case		Plastic (PBT; polyester), {aluminium}, {stainless steel 316L}
Weight	kg	approx. 4.2 ... 4.5 depending on the process connection and case version

Electrical data		
Power supply U _B	V DC	non-hazardous: 14 ... 36 Ex ia: 14 ... 30; Ex d: 20 ... 36; {FOUNDATION fieldbus™ und PROFIBUS® PA Ex ia: 9 ... 24 Ex d 12 ... 32}
Output signal		4 ... 20 mA, 2-wire {4 ... 20 mA, 2-wire with a superimposed communication signal HART®}, {FOUNDATION Fieldbus™}, {PROFIBUS® PA}
Dead time	ms	100
Time constant (63 %)	ms	180 (measuring ranges 10, 30 mbar: 250)
Damping	s	0 ... 999, adjustable
Permissible max. load	R _A in Ω	R _A = (U _B - U _{Bmin}) / 0.023 A

Explosion protection

Ex protection ⁹⁾	ATEX	Category II 1G, II 1/2G, II 2G Ex ia IIC T6...T1 II 1/2 G, II 2 G Ex d ia IIC T6...T1
-----------------------------	------	--

Ambient conditions

CE-mark		EMC 2004/108/EC interference emission and interference immunity per EN 61 326-1 industrial application Interference emission Limit Class A and B, 94/9/EC EN 50 014 (general part), EN 50 020 (intrinsic safe), EN 50 284 (zone 0), {EN 50 281-1 (dust Ex)}
Shock resistance	g	100 per IEC 60 068-2-27 (Shock mechanical)
Vibration resistance ¹⁰⁾	g	4 (5 ... 100 Hz) (Vibration under resonance)
Electrical ingress protection		Overvoltage Category III Protection Class II IP66/67 (standard housing)

- { } Items in curved brackets are optional extras for additional price.
 - 1) Other measuring ranges can be set via the respective Turndown.
 - 2) Measuring range 40 bar, "-" side overload range unilateral up to 100 bar.
 - 3) Valid with reference conditions according to IEC 60 770.
 - 4) Includes non-linearity after limit point setting, hysteresis and non-repeatability in accordance with IEC 60 770.
 - 5) Includes non-linearity, hysteresis, non-repeatability, thermal changes, zero point and static pressure influence (Pstat= 70 bar) in the temperature range -10 ... +60 °C.
 - 6) Values are not valid for tantalum diaphragm.
 - 7) Restrictions of process temperature for oxygen -20 ... +60 °C / the lowest temperature for PN 420: -10 °C.
 - 8) Operating pressure with halocarbon oil - higher than 1 bar abs.
 - 9) The operating conditions and safety-relevant data in the approval documents must be read.
 - 10) Tested in accordance with directives, GL characteristic line 2 (not for double chamber cases in stainless steel).
- URL = basic measuring range
TD = Turndown

Electrical connection

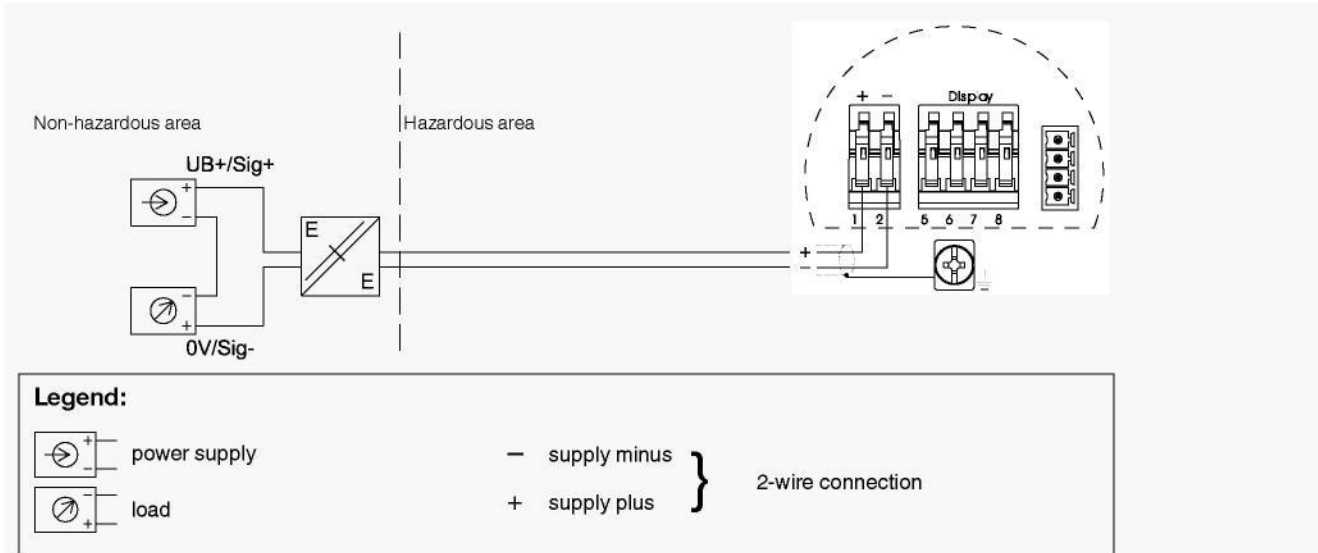

Electrical connection

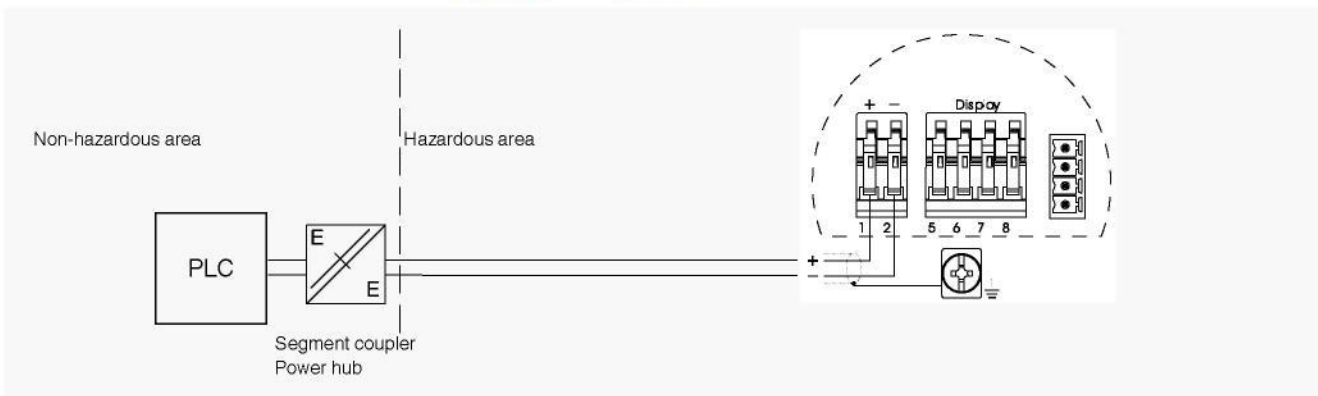

Process connection

Oval flange, connection 1/4 -18 NPT or RC 1/4 with vent at rear

Measuring cells 10 and 30 mbar

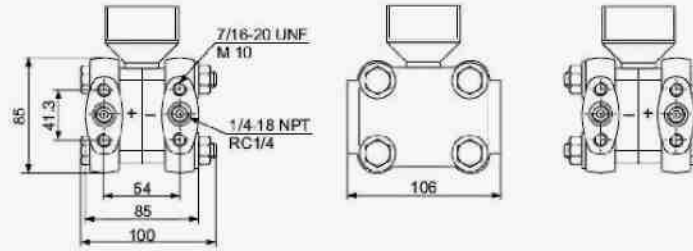

Measuring cells ≥ 100 mbar

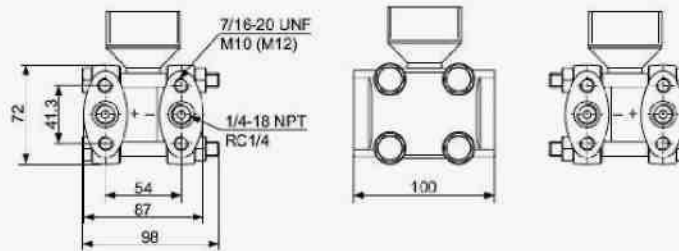

Connection	Mounting	Material	Equipment
1/4-18 NPT IEC 61518	7/16-20 UNF	Stainless steel C 22.8	2 vent valves ¹⁾
1/4-18 NPT IEC 61518	7/16-20 UNF	AISI 316L	2 vent valves ¹⁾
1/4-18 NPT IEC 61518	7/16-20 UNF	C276	Without valves / plugs
RC 1/4	7/16-20 UNF	AISI 316L	2 vent valves ¹⁾
1/4-18 NPT IEC 61518	PN 160: M10; PN 420: M12	Stainless steel C22.8	2 vent valves ¹⁾
1/4-18 NPT IEC 61518	PN 160: M10; PN 420: M12	AISI 316L	2 vent valves ¹⁾
1/4-18 NPT IEC 61518	PN 160: M10; PN 420: M12	C276	Without valves / plugs

¹⁾ Material: AISI316L /1.4404

Oval flange, connection 1/4-18 NPT or RC 1/4, with lateral venting

Measuring cells 10 and 30 mbar

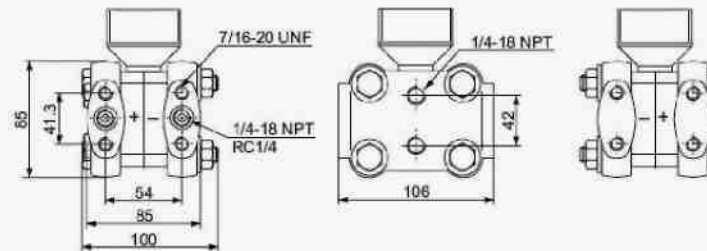

Measuring cells ≥ 100 mbar

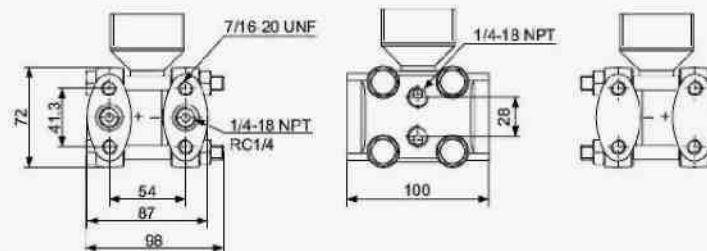

Connection	Mounting	Material	Equipment
1/4-18 NPT IEC 61518	7/16-20 UNF	Stainless steel C 22.8	2 vent valves, 4 plug screws ¹⁾
1/4-18 NPT IEC 61518	7/16-20 UNF	AISI 316L	2 vent valves, 4 plug screws ¹⁾
1/4-18 NPT IEC 61518	7/16-20 UNF	C276	Without valves / plugs
RC 1/4	7/16-20 UNF	AISI 316L	2 vent valves, 4 plug screws ¹⁾

¹⁾ Material: AISI316L /1.4404

Housing variants

Single chamber housing, plastic

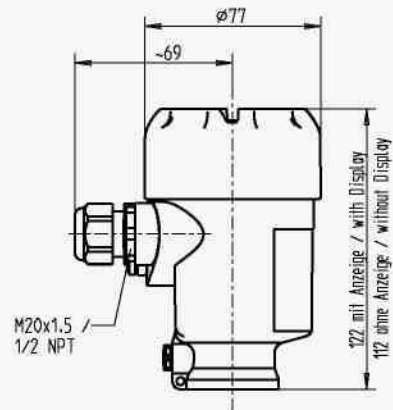

Single chamber housing, aluminium

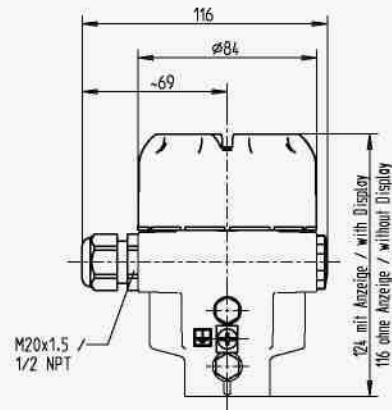

Single chamber housing, cast stainless steel

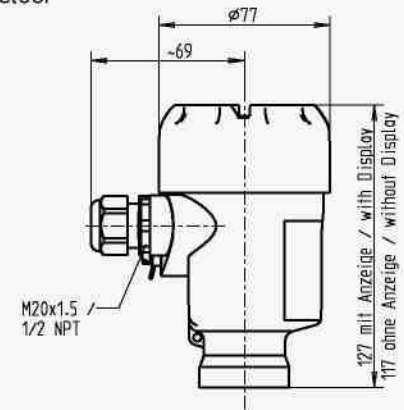

Single chamber housing, stainless steel, deep-drawn

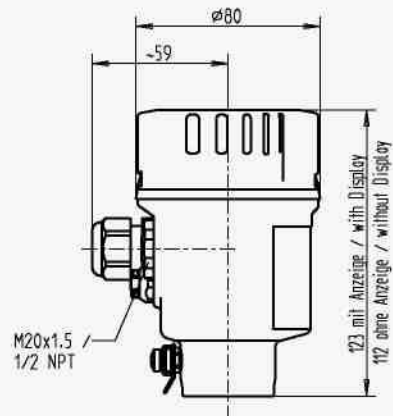

Dual chamber housing, plastic

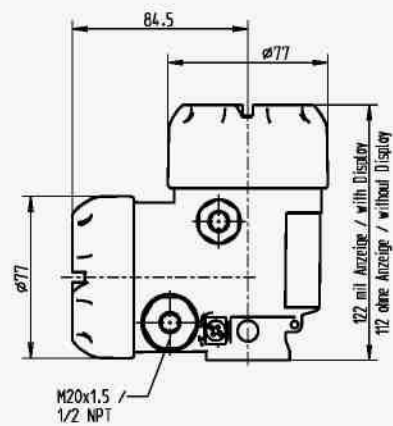

Dual chamber housing, aluminium

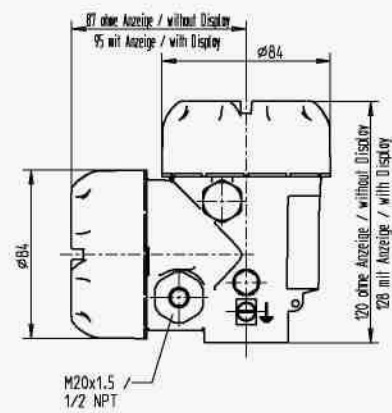

Dual chamber housing, cast stainless steel

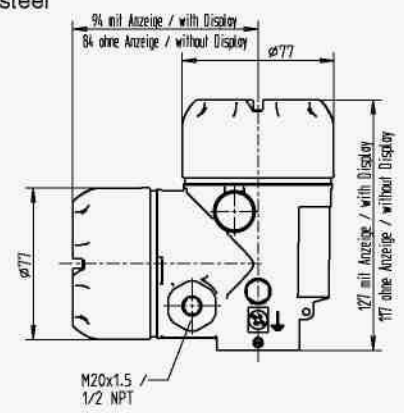

Accessories

Three-way valve manifolds

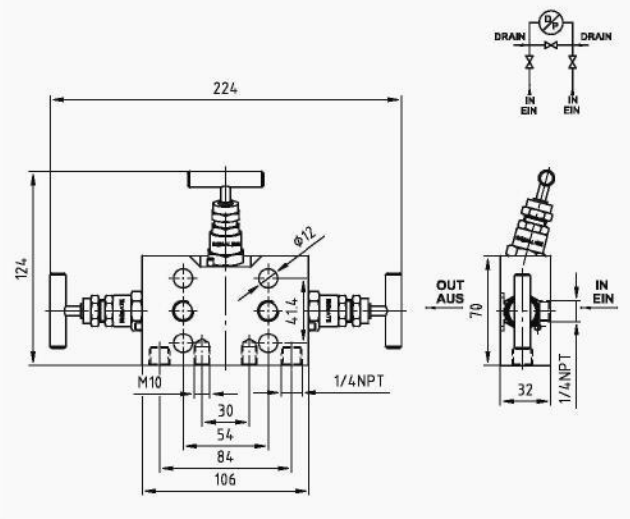

With upstream pressure equalising valves it is possible to avoid unilateral overpressure loadings during both start-up and operation as well as enabling zero point checks during operation. Furthermore, they enable the isolation of the process lines without interference to the running process.

Five-way valve manifolds

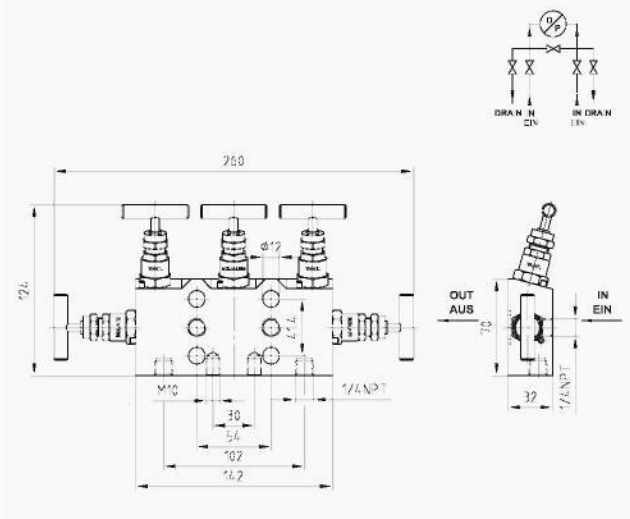

These pressure equalising valves with integrated shut-off valves, and also purge and ventilating valves, in addition enable the venting of the pressure gauge on one or both sides and enable the supply line to be purged.

Diaphragm seals



Model DPT-10 differential pressure transmitters can be adapted to the harshest conditions in the process industry by using diaphragm or diaphragm in-line seals. Thus, the transmitters can be used at extreme temperatures, and with aggressive, corrosive, heterogeneous, abrasive, highly viscous or toxic media. As a result of the wide variety of aseptic connections (such as clamp, threaded pipe or DIN 11 864 aseptic connections) measuring assemblies meet the high demands of sterile process engineering.

Differential pressure transducer



Differential pressure transducers for flow measurement are available as accessories. Depending on the application, the differential pressure transducers are designed as simple push plugs, measuring flange or complete measuring path.

Display and operating module

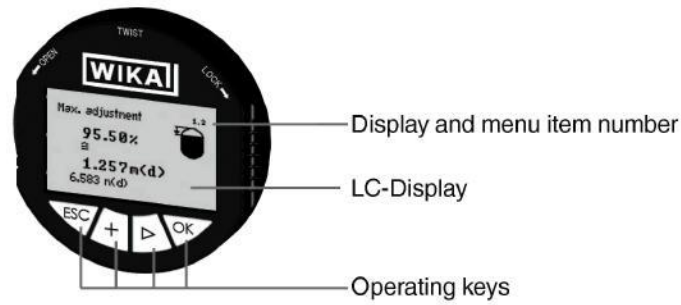

Menu languages:

German
English
French
Spanish
Polish
Italian
Dutch

DTM user interface

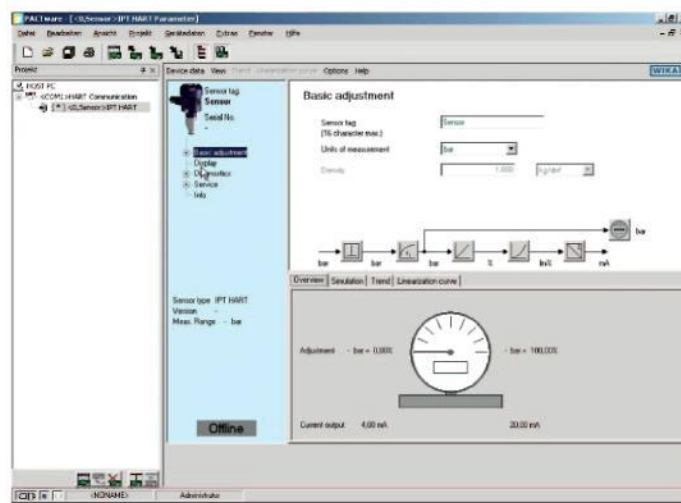

For HART output signals, Profibus-PA and FF, a DTM is available in accordance with the FDT-standard. The DTM provides a self-explanatory and clear user interface for all setup and control processes of the transmitter. For testing purposes, it is also possible to simulate process values and archive the parameter data.

Recording of the measured values is available for diagnostic purposes.

Tank volume calculation

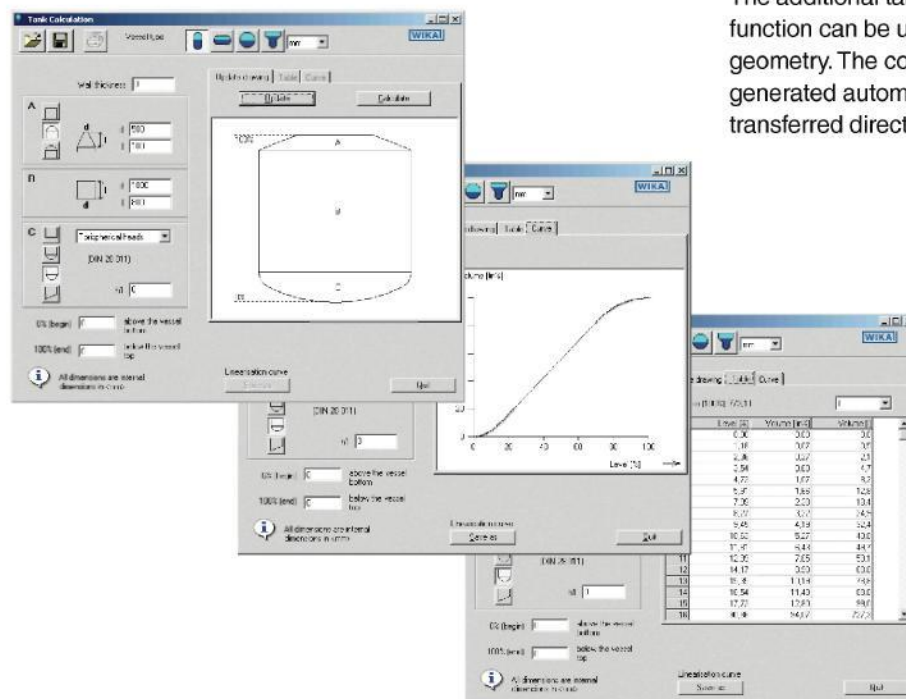

The additional tank volume calculation of the DTM function can be used to reproduce any optional tank geometry. The corresponding linearisation table is generated automatically. The linearisation table can be transferred directly to the transmitter.

Accessories

Model	Special features	Order No.
DIH52-F and DIH62-F 	Indication module DIH52-F and DIH62-F, 5-digit display, 20 segment bargraph, without separate power supply, with additional HART®-functionality. Automatic adjustment of measuring range and span. Local-master functionality: Setting the measuring range and unit of the connected transmitters using HART®-standard commands. explosion protection according to ATEX.	On request
Model 010031 	HART®-Modem for USB-interface, specifically designed for use with modern notebooks	11025166
Model 010001	HART®-Modem for RS232-interface	7957522
Model 010041	HART®-Modem for Bluetooth-interface [EEx ia] IIC	11364254
FC475HR1EKL9 	HART® protocol, Li-Ion battery, power supply 100 ... 240 V coloured indication with background lighting, Bluetooth and infrared interface ATEX, FM, CSA and IECEx(i) (including FISCO if available).	On request
FC475HR1EKL0	HART® protocol, NIMH battery, power supply AC 90 ... 240 V, with EASY UPGRADE, ATEX II 2G (1GD) EEx ia IIC T4	On request
MFC4150 	HART® protocol, universal power supply, cable set with 250 Ω resistance, with DOF upgrade, with Ex-protection 	11405333
DTM Collection 	incl. PACTware, contains DTM's for WIKA field devices	12513636
	Display and operation module, housing cover in aluminium, with window	12298884
	Display and operation module, housing cover in cast stainless steel, with window	12298906
	Display and operation module, housing cover in plastic, with window	13315277
	Display and operation module, housing cover in stainless steel, electropolished, with window	13315269
	Three-way valve CrNi-steel, PN 420, shape A, Nace compliant, 3.1 material certificate	On request
	Five-way valve CrNi-steel, PN 420, shape A, Nace compliant, 3.1 material certificate	On request
	Oval flange 1/4 NPT Cr-Ni-steel CrNi-steel, PN 420, shape A, Nace compliant, 3.1 material certificate	On request
	Oval flange 1/2 NPT Cr-Ni-steel CrNi-steel, PN 420, shape A, Nace compliant, 3.1 material certificate	On request
	Mounting bracket for wall or pipe mounting, stainless steel	11553945

The specifications given in this document represent the state of engineering at the time of publishing.
We reserve the right to make modifications to the specifications and materials.

ООО ТД «АЗТЭО»
624260, Россия Свердловская область,
г. Асбест, пр. Ленина, 8/3
Тел: 8 (34365) 2-87-74, 2-45-52
Факс: 8 (34365) 2-87-74
E-mail: zakaz@azteo.ru