

Miniature resistance thermometer For sanitary applications Model TR21-A, with flange connection

WIKA data sheet TE 60.26



Applications

- Sanitary applications
- Food and beverage industry
- Bio and pharmaceutical industry, production of active ingredients

Special features

- Sensor can be calibrated without having to open the process
- Compact design for space-saving fitting
- Simple and fast connection using an M12 plug connector
- With direct sensor output (Pt100/Pt1000 in 3 or 4-wire version) or integrated transmitter with 4 ... 20 mA output signal, individually parameterisable with free-of-charge WIKAsoft-TT PC configuration software
- Materials and surface finish quality in accordance with standards of hygienic designs

Description

The model TR21-A resistance thermometer provides temperature measurement in sanitary applications and can be used for the measurement of liquid and gaseous media in the range of -50 ... +250 °C. These thermometers are fitted with thermowells, whose process connections meet the stringent requirements, in terms of materials and design, of hygienic measuring points. All electrical components are protected against moisture (IP 67 or IP 69K).

The resistance thermometer is available with direct sensor output or integrated transmitter, which can be configured individually via the PC configuration software WIKAsoft-TT. Measuring range, damping, fault signal per NAMUR NE43 and TAG no. can be adjusted.

For easy calibration or maintenance, the sensor is removable without having to break into the process or disconnect the electrical connection. Thus hygiene risks can be minimised and downtimes can be reduced.



Resistance thermometer with VARIVENT® connection, model TR21-A

The spring-loading, integrated into the union nut, guarantees the contact between the sensor tip and the bottom of the thermowell and thus ensures a short response time and lasting high accuracy.

The welded junction between the thermowell and the flange makes the use of a sealing as additional material in those areas redundant which are in contact with the product.

Insertion length, process connection, sensor and connection method can each be selected for the respective application within the order information. The electrical connection is made via an M12 x 1 circular connector. An adapter for electrical connection with angular connector per DIN EN 175301-803 form A is optionally available (patent, property right registered under No. 001370985).

Specifications

Thermometer with direct sensor output with Pt100 or Pt1000	
Temperature range	-50 ... +150 °C (-58 ... +302 °F), -50 ... +250 °C (-58 ... +482 °F)
Measuring element	<ul style="list-style-type: none"> ■ Pt100 (measuring current: 0.1 ... 1.0 mA) ■ Face-sensitive Pt100 (measuring current 0.1 ... 1.0 mA) ¹⁾ ■ Pt1000 (measuring current: 0.1 ... 0.3 mA) ■ Face-sensitive Pt1000 (measuring current 0.1 ... 0.3 mA) ¹⁾
Temperature at the connector	max. 85 °C (185 °F)
Connection method	<ul style="list-style-type: none"> ■ 3-wire With a cable length of 30 m or longer, measuring deviations can occur. ■ 4-wire The lead resistance can be ignored.
Tolerance value of the measuring element per IEC 60751 ²⁾	<ul style="list-style-type: none"> ■ Class AA (1/3 DIN) ■ Class A ■ Class B
Response time (per IEC 60751)	t ₅₀ < 4.7 s t ₉₀ < 12.15 s
Electrical connection	M12 x 1, 4-pin circular connector

For detailed specifications for Pt sensors, see Technical information IN 00.17 at www.wika.com.

Thermometer with transmitter and output signal 4 ... 20 mA	
Temperature range	-50 ... +150 °C (-58 ... +302 °F), -50 ... +250 °C (-58 ... +482 °F) ³⁾
Measuring element	<ul style="list-style-type: none"> ■ Pt1000 ■ Face-sensitive Pt1000 ¹⁾
Connection method	2-wire
Tolerance value of the measuring element per IEC 60751 ²⁾	<ul style="list-style-type: none"> ■ Class AA (1/3 DIN) ■ Class A ■ Class B
Measuring span	minimum 20 K, maximum 300 K
Measuring deviation of the transmitter per IEC 60770	±0.25 K
Total measuring deviation in accordance with IEC 60770	Measuring deviation of the measuring element + the transmitter
Basic configuration	Measuring range 0 ... 150 °C (32 ... 302 °F), other measuring ranges are adjustable
Analogue output	4 ... 20 mA, 2-wire
Linearisation	Linear to temperature per IEC 60751
Linearisation error	±0.1 % ⁴⁾
Switch-on delay, electrical (time before the first measured value)	max. 4 s
Warming-up period	After approx. 4 minutes, the instrument will function to the specifications (accuracy) given in the data sheet.
Current signals for fault signal	configurable in accordance with NAMUR NE43 downscale ≤ 3.6 mA upscale ≥ 21.0 mA
Sensor short-circuit	not configurable, in accordance with NAMUR NE43 downscale ≤ 3.6 mA
Sensor current	< 0.3 mA (self-heating can be ignored)
Load R _A	R _A ≤ (U _B - 10 V) / 23 mA with R _A in Ω and U _B in V
Effect of load	±0.05 % / 100 Ω
Power supply U _B	DC 10 ... 30 V
Max. permissible residual ripple	10 % generated by U _B < 3 % ripple of the output current
Power supply input	protected against reverse polarity
Power supply effect (depending on the power supply U _B)	±0.025 % / V
Influence of the ambient temperature	0.1 % of span / 10 K T _{amb}
Electromagnetic compatibility (EMC) ⁶⁾	2004/108/EC, EN 61326 emission (group 1, class B) and interference immunity (industrial application) ⁵⁾ , configuration at 20 % of the full measuring range
Temperature units	configurable °C, °F, K
Info data	TAG No., description and user message can be stored in transmitter
Configuration and calibration data	permanently stored
Response time (per IEC 60751)	t ₅₀ < 4.7 s t ₉₀ < 12.15 s
Electrical connection	M12 x 1, 4-pin circular connector

Readings in % refer to the measuring span

For a correct determination of the overall measuring deviation, both sensor and transmitter measuring deviations have to be considered.

1) Through their small design, face-sensitive measuring resistors serve to reduce the heat dissipation with short insertion lengths.

Available for the temperature range up to 150 °C (302 °F) in classes A and B.

For thermowell insertion lengths of less than 11 mm, face-sensitive measuring resistors are generally used.

2) Class accuracy AA (1/3 DIN) only valid in the temperature range 0 ... 150 °C (32 ... 302 °F)

Class accuracy A only valid in the temperature range -30 ... +150 °C (-22 ... +302 °F) or -30 ... +250 °C (-22 ... +482 °F), otherwise Class B

3) The temperature transmitter should therefore be protected from temperatures over 65 °C (185 °F).

4) ±0.2 % for measuring ranges with a lower limit less than 0 °C (32 °F)

5) Use resistance thermometers with shielded cable, and ground the shield on at least one end of the lead, if the lines are longer than 30 m or leave the building. The instrument must be operated grounded.

6) During interference consider an increased measuring deviation of up to 2 %.

Case	
Material	Stainless steel
Ingress protection	
<ul style="list-style-type: none"> ■ Case with connected connector 	IP 67 and IP 69K per IEC 60529/EN 60529 The stated ingress protection only applies when plugged in using mating connectors that have the appropriate ingress protection.
<ul style="list-style-type: none"> ■ Coupler connector, not connected 	IP 67 per IEC 60529/EN 60529
Weight in kg	approx. 0.3 ... 2.5 (depending on version)

Ambient conditions	
Ambient temperature range	-50 ... +85 °C (-58 ... 185 °F)
Storage temperature range	-40 ... +85 °C (-40 ... 185 °F)
Climate class per IEC 60654-1	Cx (-50 ... +85 °C or -58 ... +185 °F, 5 ... 95 % relative humidity)
Maximum permissible humidity per IEC 60068-2-30 var. 2	relative humidity 100 %, condensation allowed
Shock	IEC 60068-2-27
Salt fog	IEC 60068-2-11

Thermowell model TW22	
Surface roughness	Standard: $R_a \leq 0.76 \mu\text{m}$ (SF3 per ASME BPE) Optional: $R_a \leq 0.38 \mu\text{m}$ (SF4 per ASME BPE) $R_a \leq 0.38 \mu\text{m}$ electropolished (SF4 per ASME BPE)
Materials	Wetted parts: stainless steel 1.4435 (316L, UNS S31603)
Connection to thermometer	G 3/8"
Thermowell diameter	6 mm, optional: probe tip reduced to 4.5 mm (from $U_1 > 25 \text{ mm}$)
Insertion length U_1 ⁷⁾	Standard: 25, 50, 75, 100, 150, 200 mm other insertion lengths are available as options
Pressure ratings	cf. tables of dimensions

7) For the TR21-A design without thermowell, the insertion length is defined by the dimension I_1 (see dimensions in mm).
The thickness of bottom of the thermowell can be neglected for dimensioning. It is offset by the spring travel of the measuring insert.

Overview of combinations

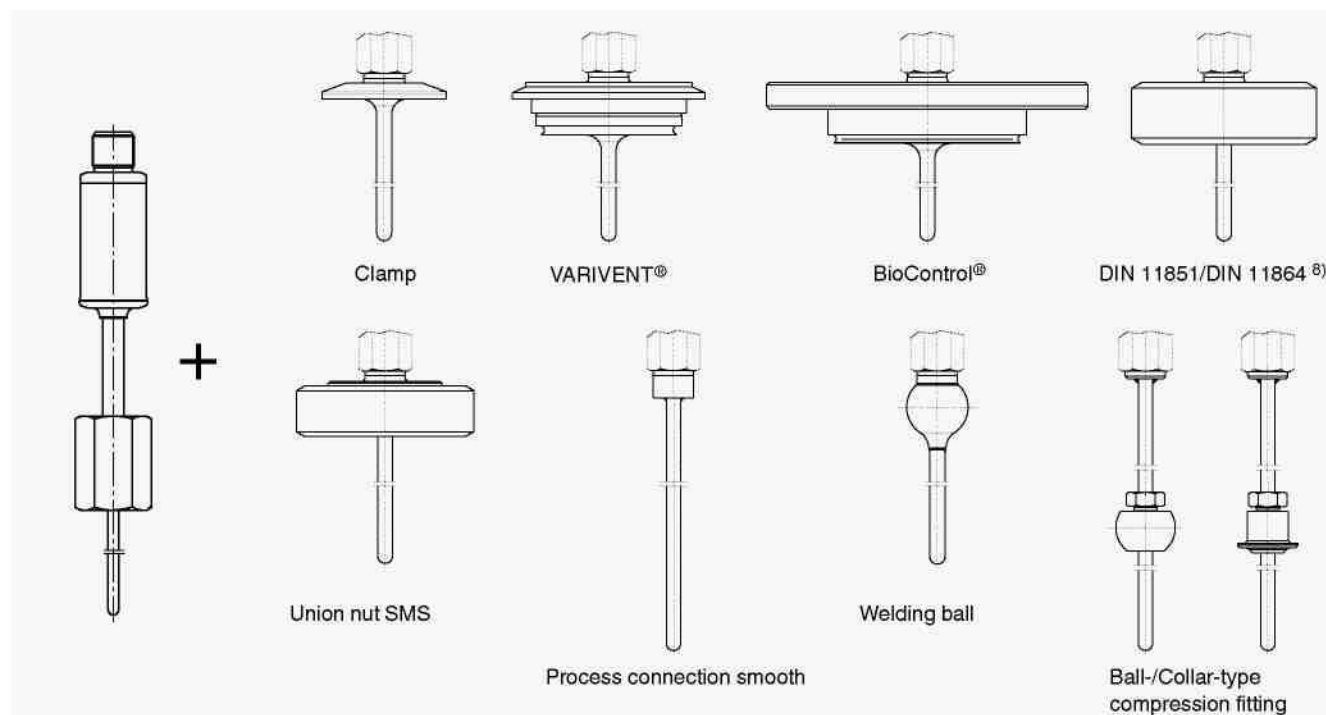

8) Process connections per DIN 11864-2 and DIN 11864-3, see "Dimensions of the process connections in mm"

VARIVENT® is a registered trademark of the company GEA Tuchenhagen.
BioControl® is a registered trademark of the company NEUMO.

Dimensions in mm

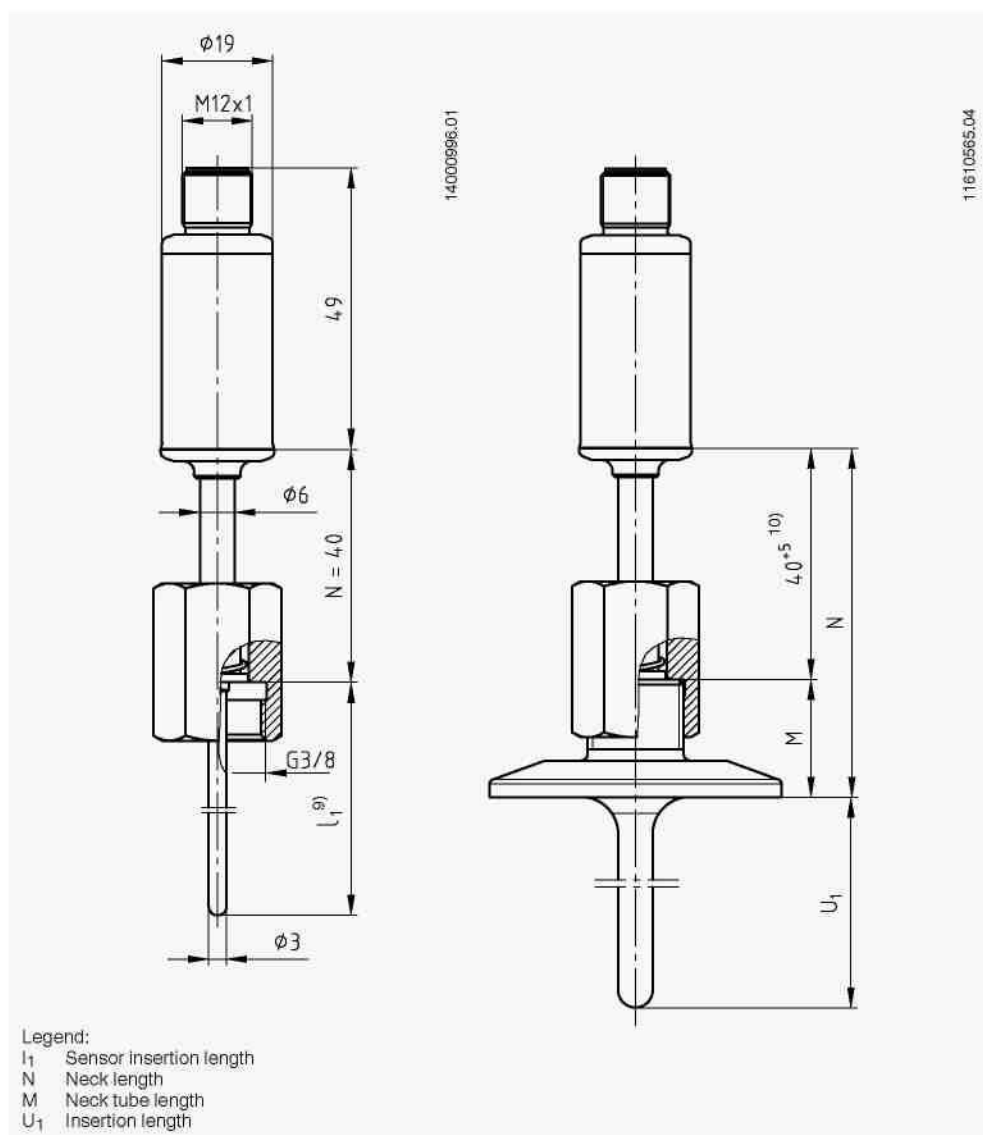

9) In the event of replacement, calculate the sensor insertion length, l_1 , as follows:
 $l_1 (TR21-A) = U_1 + M$

10) The tolerance specification is dependent on the spring travel of the sensor/probe

Dimensions of the process connections in mm (model TW22 thermowells)

Clamp process connection

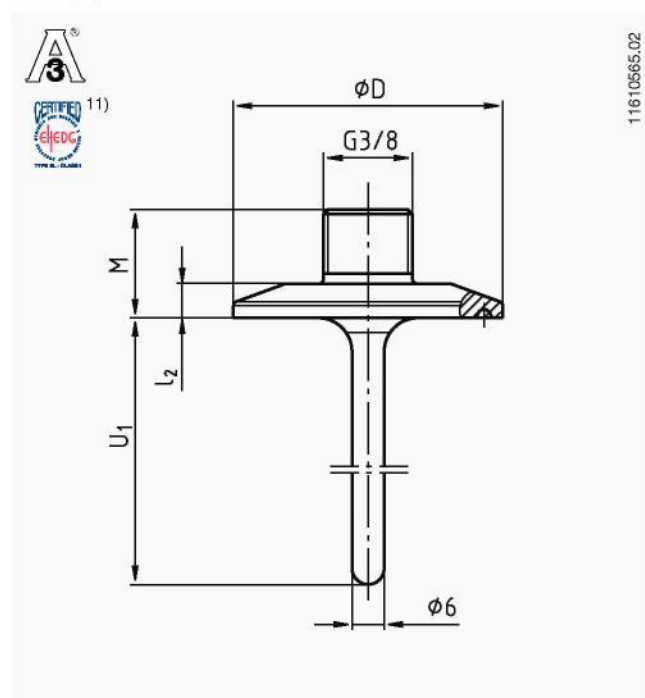

U_1 = variable insertion length

11) In combination with
 - Kalrez/Stainless steel gasket from Dupont de Nemours, Switzerland or
 - T-ring seals from Combit International B. V., Netherlands

VARIVENT® process connection

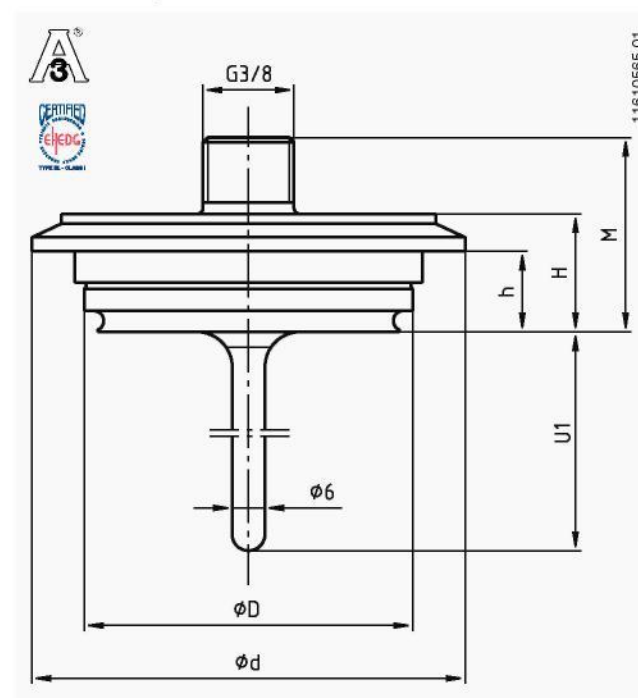

U_1 = variable insertion length

Dimensions for clamp process connection

Process connection	Nominal width in mm/inch	PN in bar	Dimensions in mm			Weight in kg
			ϕD	M	l_2	
DIN 32676 for pipes per DIN 11866 series A	DN 10 ... 20	16	34.0	20.35	6.35	0.2
	DN 25 ... 40	16	50.5	20.35	6.35	0.3
	DN 50	16	64.0	20.35	6.35	0.4
DIN 32676 for pipes per DIN 11866 series B	13.5 ... 17.2	16	25.0	18.75	4.75	0.2
	21.3 ... 33.7	16	50.5	20.35	6.35	0.3
	42.4 ... 48.3	16	64.0	20.35	6.35	0.3
DIN 32676 for pipes per DIN 11866 series C	1/2" ... 3/4"	16	25.0	18.75	4.75	0.2
	1" ... 1 1/2"	16	50.5	20.35	6.35	0.3
	2"	16	64.0	20.35	6.35	0.4
Tri-clamp	1/2"	16	25.0	18.75	4.75	0.2
	3/4"	16	25.0	18.75	4.75	0.2
	1"	16	50.5	20.35	6.35	0.3
	1 1/2"	16	50.5	20.35	6.35	0.3
	2"	16	64.0	20.35	6.35	0.4
	2 1/2"	16	77.5	20.35	6.35	0.5
ISO 2852	DN 12 ... 21.3	16	34.0	20.35	6.35	0.2
	DN 25 ... 38	16	50.5	20.35	6.35	0.3
	DN 40 ... 51	16	64.0	20.35	6.35	0.4

Dimensions for VARIVENT® process connection

Process connection	Nominal width in mm	PN in bar	Dimensions in mm					Weight in kg
			ϕD	M	ϕd	H	h	
Form B	DN 10, DN 15	25	31	34	52.7	20	13.65	0.3
Form F	DN 25, DN 32	25	50	32	66.0	18	12.30	0.4
Form N	DN 40, DN 50	16	68	32	84.0	18	12.30	0.6

NEUMO BioControl® process connection

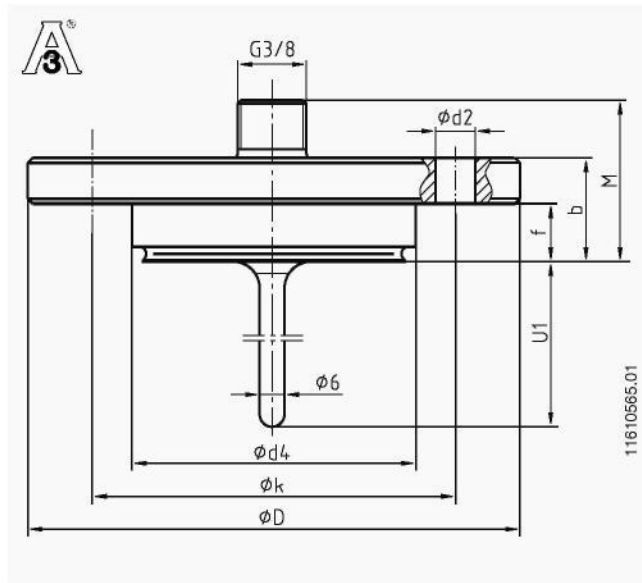

U₁ = variable insertion length

For a detailed description of the BioControl® cases, see data sheet AC 09.14.

Union nut process connection DIN 11851 with conical coupling (milk thread fitting)

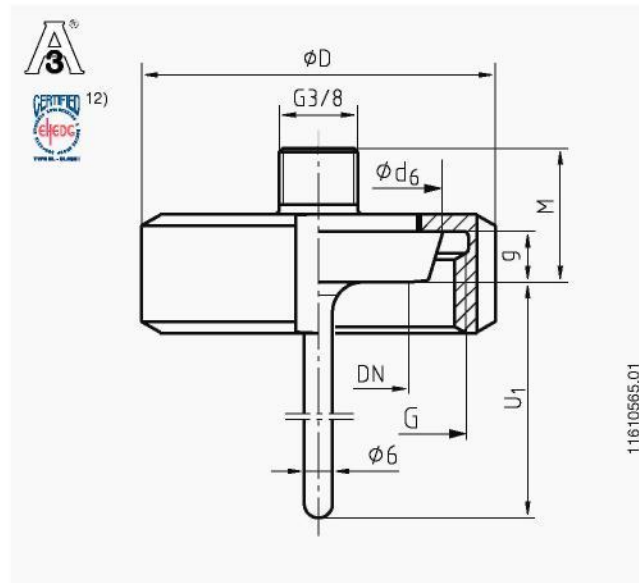

U₁ = variable insertion length

12) In combination with
- ASEPTO-STAR k-flex upgrade gaskets from Kieselmann GmbH, Germany or
- SKS gasket set DIN 11851 EHEDC from Siersema Komponenten

Dimensions for NEUMO BioControl® process connection

Case size	Nominal width in mm	PN in bar	Dimensions in mm								Weight in kg
			U ₁ ¹³⁾	Ø d ₄	Ø D	M	f	b	Ø k	Ø d ₂	
Size 25	DN 8	16	5	30.5	64	34	11	20	50	4 x Ø 7	0.4
	DN 10	16	6	30.5	64	34	11	20	50	4 x Ø 7	0.4
	DN 15	16	9	30.5	64	34	11	20	50	4 x Ø 7	0.4
	DN 20	16	11	30.5	64	34	11	20	50	4 x Ø 7	0.4
Size 50	DN 25	16	15	50.0	90	41	17	27	70	4 x Ø 9	0.8
	DN 40	16	20	50.0	90	41	17	27	70	4 x Ø 9	0.8
	DN 50	16	25	50.0	90	41	17	27	70	4 x Ø 9	0.8
	DN 65	16	35	50.0	90	41	17	27	70	4 x Ø 9	0.8
	DN 80	16	45	50.0	90	41	17	27	70	4 x Ø 9	0.8
	DN 100	16	55	50.0	90	41	17	27	70	4 x Ø 9	0.8
Size 65	DN 40	16	20	68.0	120	41	17	27	95	4 x Ø 11	1.4
	DN 50	16	25	68.0	120	41	17	27	95	4 x Ø 11	1.4
	DN 65	16	35	68.0	120	41	17	27	95	4 x Ø 11	1.4
	DN 80	16	45	68.0	120	41	17	27	95	4 x Ø 11	1.4
	DN 100	16	55	68.0	120	41	17	27	95	4 x Ø 11	1.4

13) Recommended insertion length for installation in BioControl® flow-through housing; other insertion lengths are possible

Dimensions for union nut process connection DIN 11851 with conical coupling (milk thread fitting)

Nominal width in mm	PN in bar	Dimensions in mm					Weight in kg
		Ø d ₆	G	Ø D	M	g	
DN 20	40	36.5	RD 44 x 1/6	54	25	8	0.4
DN 25	40	44.0	RD 52 x 1/6	63	27	10	0.5
DN 32	40	50.0	RD 58 x 1/6	70	27	10	0.6
DN 40	40	56.0	RD 65 x 1/6	78	27	10	0.8
DN 50	25	68.5	RD 78 x 1/6	92	28	11	0.9

**Process connection, aseptic threaded pipe connection DIN 11864-1
with form A collar connecting sleeve, for pipes in accordance with DIN 11866 series A, B and C**

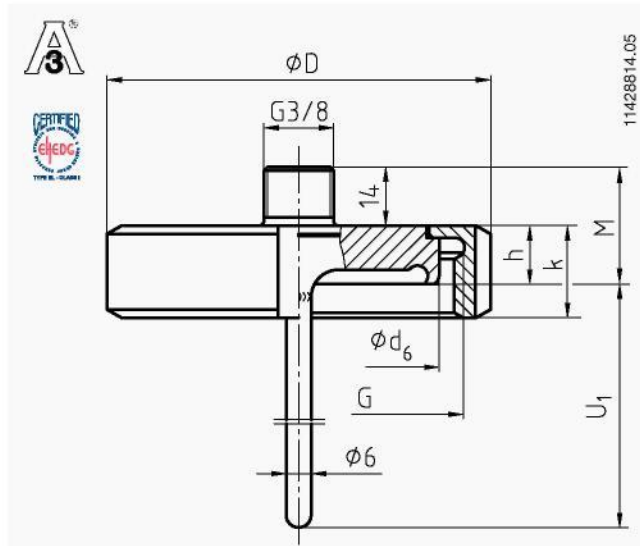

U_1 = variable insertion length

Nominal width of pipe DN / OD	Nominal pressure in bar PN ^{1) 2)}	Outer diameter of pipe	Pipe schedule s	Inner diameter of pipe	Process connection					Aseptic O-ring	Weight in kg
					OD	M	G	h	k		
DIN 11866 series A or metric											
10	40	13	1.5	10	38	23	RD 28 x 1/8	9	18	12 x 3.5	1.2
15	40	19	1.5	16	44	23	RD 34 x 1/8	9	18	18 x 3.5	1.2
20	40	23	1.5	20	54	24	RD 44 x 1/6	10	20	22 x 3.5	1.25
25	40	29	1.5	26	63	26	RD 52 x 1/6	12	21	28 x 3.5	1.4
32	40	35	1.5	32	70	27	RD 58 x 1/6	13	21	34 x 5	1.45
40	40	41	1.5	38	78	27	RD 65 x 1/6	13	21	40 x 5	1.6
50	25	53	1.5	50	92	28	RD 78 x 1/6	14	22	52 x 5	1.7
DIN 11866 series B or ISO											
13.5	40	13.5	1.6	10.3	38	23	RD 28 x 1/8	9	18	12 x 3.5	1.2
17.2	40	17.2	1.6	14	44	23	RD 34 x 1/8	9	18	16 x 3.5	1.2
21.3	40	21.3	1.6	18.1	54	24	RD 44 x 1/6	10	20	20 x 3.5	1.3
26.9	40	26.9	1.6	23.7	63	26	RD 52 x 1/6	12	21	26 x 3.5	1.4
33.7	40	33.7	2	29.7	70	27	RD 58 x 1/6	13	21	32 x 5	1.5
42.4	25	42.4	2	38.4	78	27	RD 65 x 1/6	13	21	40.5 x 5	1.6
48.3	25	48.3	2	44.3	92	28	RD 78 x 1/6	14	22	46.6 x 5	1.7
DIN 11866 series C or ASME BPE											
1/2"	40	12.7	1.65	9.4	38	23	RD 28 x 1/8	9	18	12 x 3.5	1.2
3/4"	40	19.05	1.65	15.75	44	23	RD 34 x 1/8	9	18	18 x 3.5	1.2
1"	40	25.4	1.65	22.1	63	26	RD 52 x 1/6	12	21	24 x 3.5	1.4
1 1/2"	40	38.1	1.65	34.8	78	27	RD 65 x 1/6	13	21	37 x 5	1.6
2"	25	50.8	1.65	47.5	92	28	RD 78 x 1/6	14	22	50 x 5	1.7

Process connection Aseptic flange DIN 11864-2, form A for pipes in accordance with DIN 11866 series A

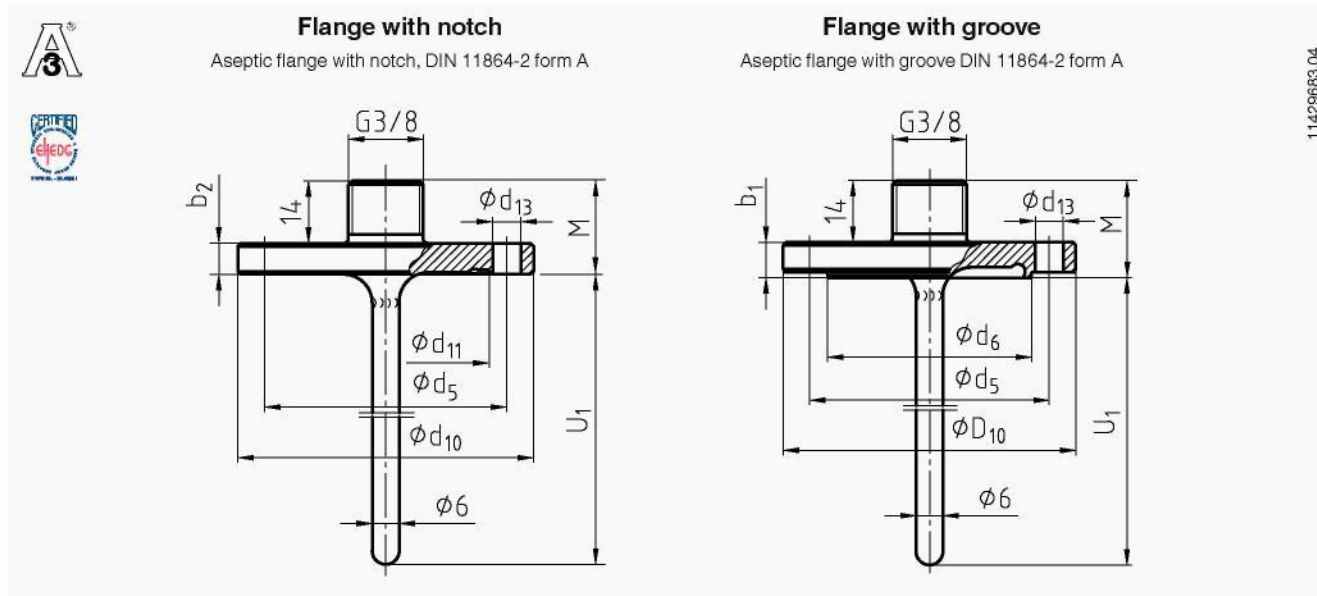

Process connection	Nominal width in mm	PN in bar	Dimensions in mm								Aseptic O-ring	Weight in kg
			M	b ₁	b ₂	Ø d ₅	Ø d ₆	Ø d ₁₀	Ø d ₁₁	Ø d ₁₃		
Flange with notch	DN 10	25	24	-	10	37	-	54	22.4	4 x Ø 9	12 x 3.5	0.2
	DN 15	25	24	-	10	42	-	59	28.4	4 x Ø 9	18 x 3.5	0.25
	DN 20	25	24	-	10	47	-	64	32.4	4 x Ø 9	22 x 3.5	0.3
	DN 25	25	24	-	10	53	-	70	38.4	4 x Ø 9	28 x 3.5	0.4
	DN 32	25	24	-	10	59	-	76	47.7	4 x Ø 9	34 x 5	0.5
	DN 40	25	24	-	10	65	-	82	53.7	4 x Ø 9	40 x 5	0.6
	DN 50	16	24	-	10	77	-	94	65.7	4 x Ø 9	52 x 5	0.6
Flange with groove	DN 10	25	25.5	11.5	-	37	22.3	54	-	4 x Ø 9	12 x 3.5	0.25
	DN 15	25	25.5	11.5	-	42	28.3	59	-	4 x Ø 9	18 x 3.5	0.3
	DN 20	25	25.5	11.5	-	47	32.3	64	-	4 x Ø 9	22 x 3.5	0.3
	DN 25	25	25.5	11.5	-	53	38.3	70	-	4 x Ø 9	28 x 3.5	0.4
	DN 32	25	25.5	11.5	-	59	47.6	76	-	4 x Ø 9	34 x 5	0.45
	DN 40	25	25.5	11.5	-	65	56.6	82	-	4 x Ø 9	40 x 5	0.6
	DN 50	16	25.5	11.5	-	77	65.6	94	-	4 x Ø 9	52 x 5	0.7

Connections for pipes in accordance with DIN 11866 series B (ISO pipes) and series C (ASME pipes) available on request.

Aseptic clamp process connection, DIN 11864-3, form A for pipes in accordance with DIN 11866 series A

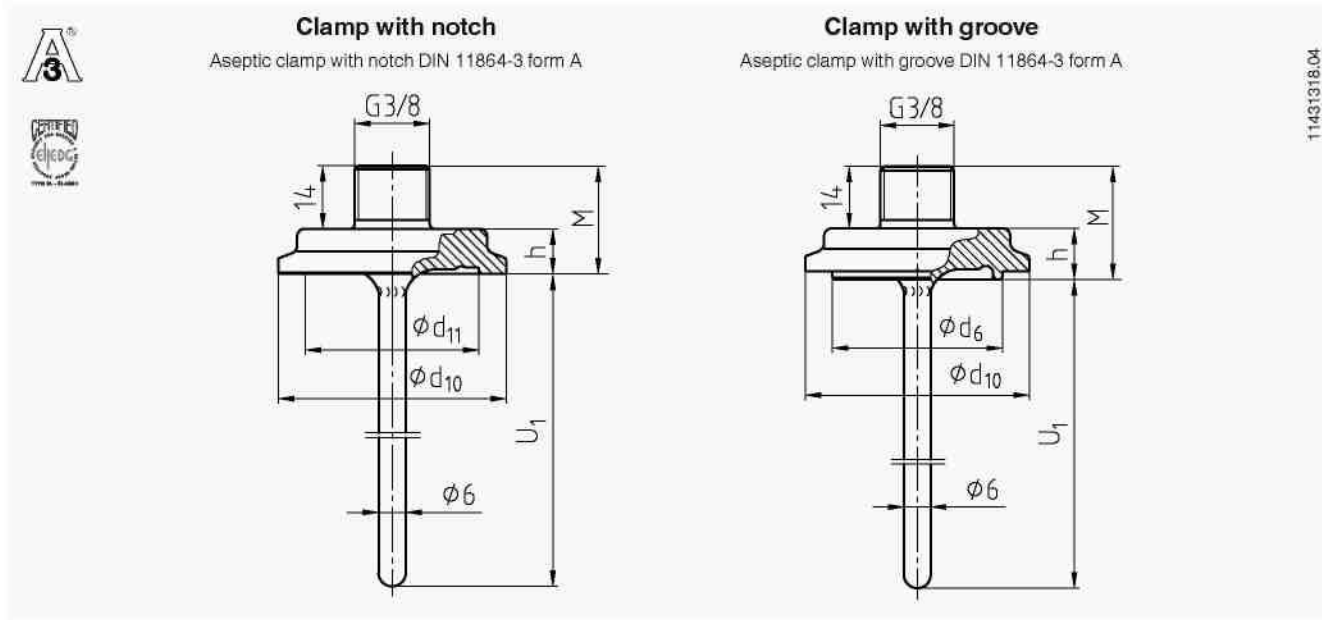

Process connection	Nominal width in mm	PN in bar	Dimensions in mm					Aseptic O-ring	Weight in kg
			M	Ø d ₆	Ø d ₁₀	Ø d ₁₁	h		
Clamp with notch	DN 10	40	25.5	-	34	22.4	11.5	12 x 3.5	0.2
	DN 15	40	25.5	-	34	28.4	11.5	18 x 3.5	0.2
	DN 20	40	25.5	-	50.5	32.4	11.5	22 x 3.5	0.3
	DN 25	40	25.5	-	50.5	38.4	11.5	28 x 3.5	0.3
	DN 32	40	25.5	-	50.5	47.7	11.5	34 x 5	0.3
	DN 40	40	25.5	-	64	53.7	11.5	40 x 5	0.4
	DN 50	25	27.5	-	77.5	65.7	13.5	52 x 5	0.5
Clamp with groove	DN 10	40	27	22.3	34	-	13	12 x 3.5	0.2
	DN 15	40	27	28.3	34	-	13	18 x 3.5	0.2
	DN 20	40	27	32.3	50.5	-	13	22 x 3.5	0.3
	DN 25	40	27	38.3	50.5	-	13	28 x 3.5	0.3
	DN 32	40	27	47.6	50.5	-	13	34 x 5	0.3
	DN 40	40	27	53.6	64	-	13	40 x 5	0.4
	DN 50	25	29	65.6	77.5	-	15	52 x 5	0.5

Connections for pipes in accordance with DIN 11866 series B (ISO pipes) and series C (ASME pipes) available on request.

Union nut process connection SMS

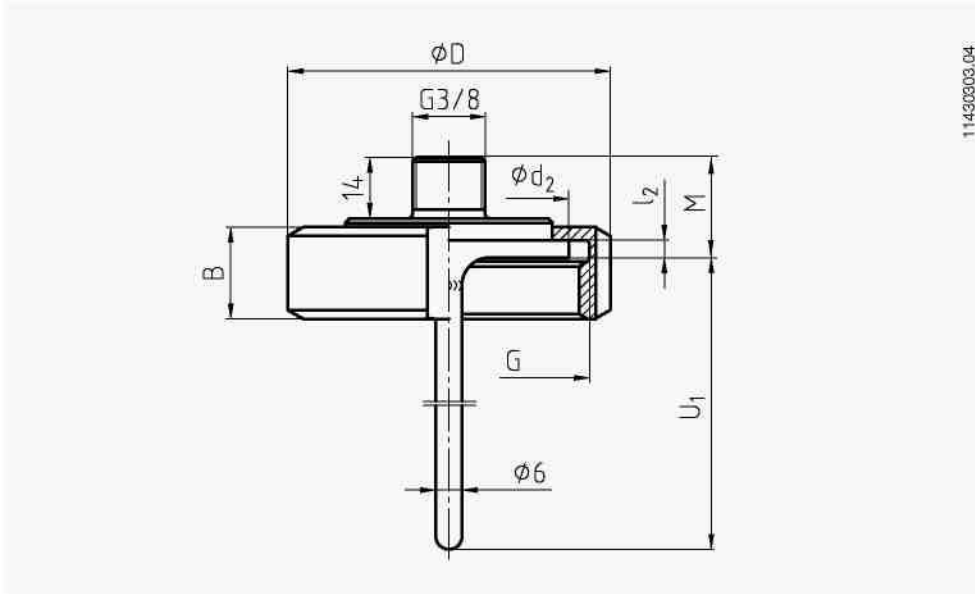

Nominal width in inch	PN in bar	Dimensions in mm						Weight in kg
		Ø D	M	Ø d ₂	B	l ₂	G	
1"	40	51	22	35.5	25	3.5	RD 40 x 1/6	0.4
1½"	40	74	23	55	25	4	RD 60 x 1/6	0.8
2"	40	84	23	65	26	4	RD 70 x 1/6	1.0

Smooth process connection, Ø 6 mm, basic shape for compression fitting

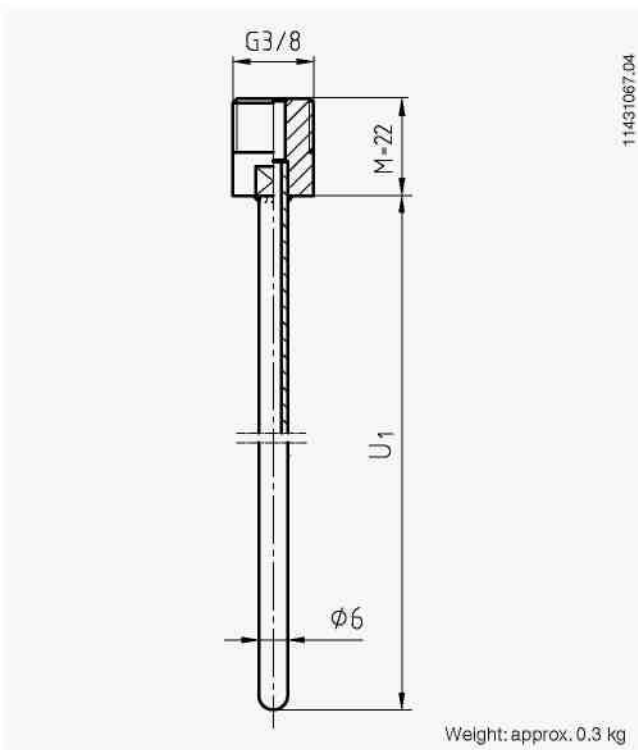

Welding ball process connection

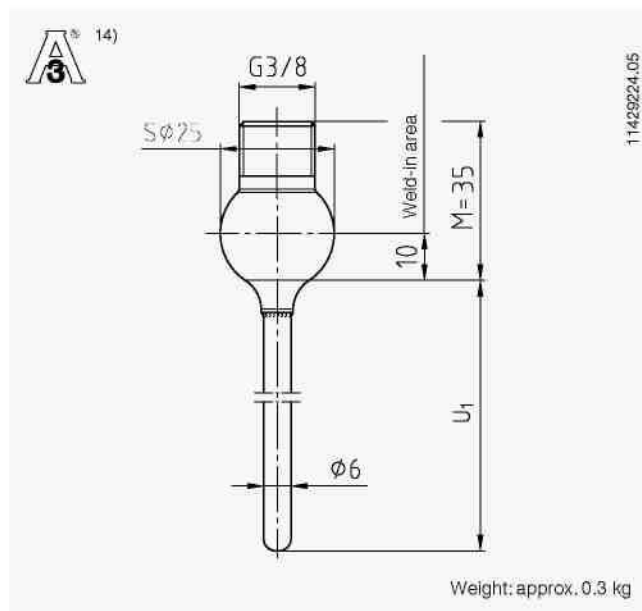

14) In order to meet the 3-A standards, the weld seam has to be carried out with a minimum radius of 3.2 mm on the product side. In this way, no weld defects, such as recesses or gaps, remain.

Compression fitting process connection

Ball-type compression fitting

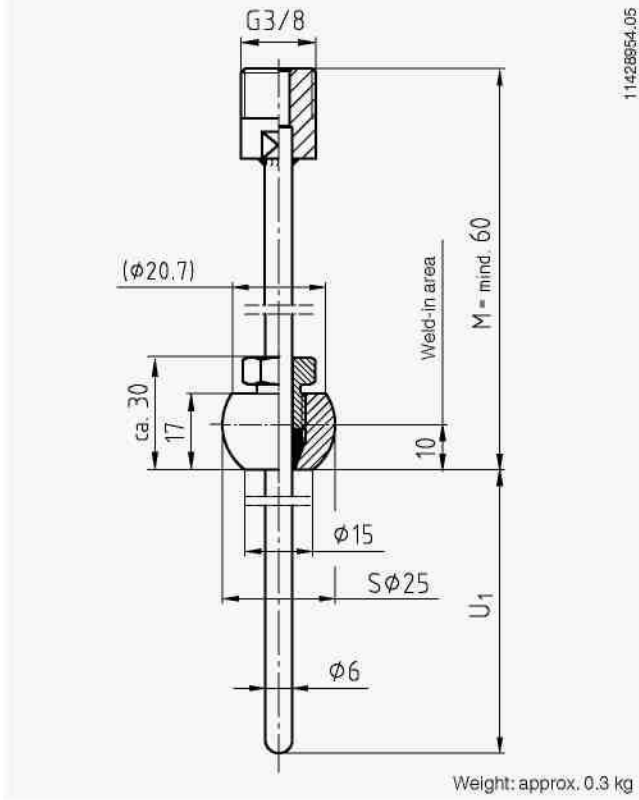

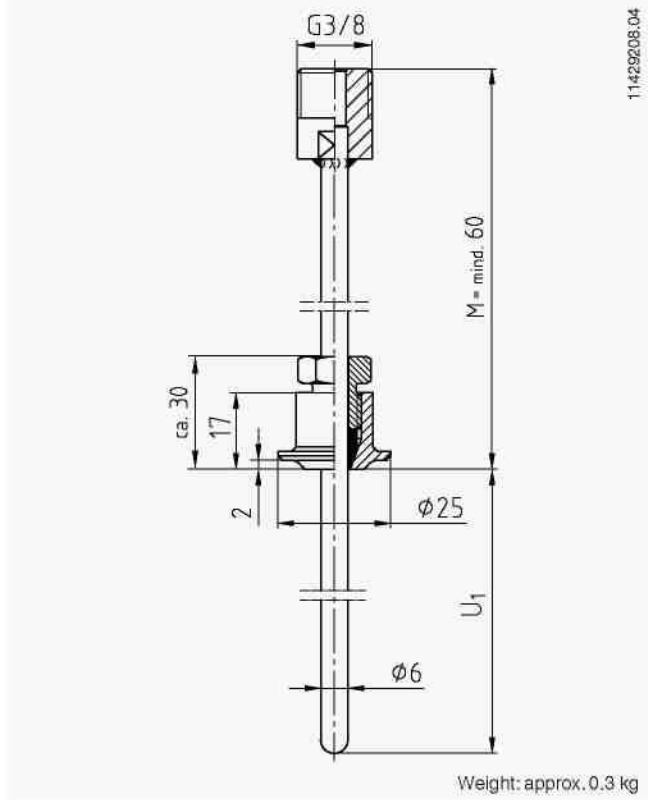

Collar-type compression fitting



Other process connections and nominal widths available on request.

Accessories

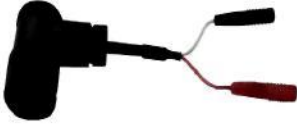
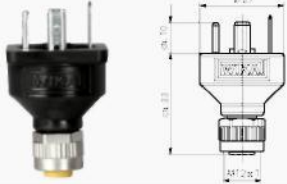
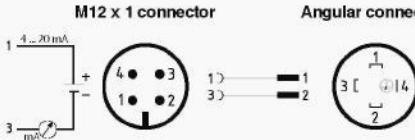
Configuration set

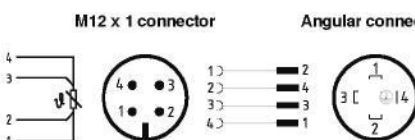
Model	Special features	Order no.
Programming unit Model PU-448 	<ul style="list-style-type: none"> Easy to use LED status/diagnostic displays Compact design No further voltage supply is needed for either the programming unit or for the transmitter 	11606304
Adapter cable M12 to PU-448 	Adapter cable for the connection of a model TR21-A resistance thermometer to the model PU-448 programming unit	14003193
M12 x 1 transmitter adapter to angular connector DIN EN 175301-803 (yellow female connector element) 	Adapter for the connection of a resistance thermometer with a DIN EN 175301-803 form A angular connector with a 4 ... 20 mA output signal (data sheet AC 80.17)  <p> Case: PA Ambient temperature: -40 ... +115 °C Union nut: zinc diecast Contacts: copper-zinc alloy, tin-plated Dielectric strength: 500 V Ingress protection: IP 65 </p>	14069503
M12 x 1 Pt adapter to angular connector DIN EN 175301-803 (black female connector element) 	Adapter for the connection of the resistance thermometer with a DIN EN 175301-803 form A angular connector with direct resistance output signal (data sheet AC 80.17)  <p> Case: PA Ambient temperature: -40 ... +115 °C Union nut: zinc diecast Contacts: copper-zinc alloy, tin-plated Dielectric strength: 500 V Ingress protection: IP 65 </p>	14061115

Configuration software WIKAsoft-TT

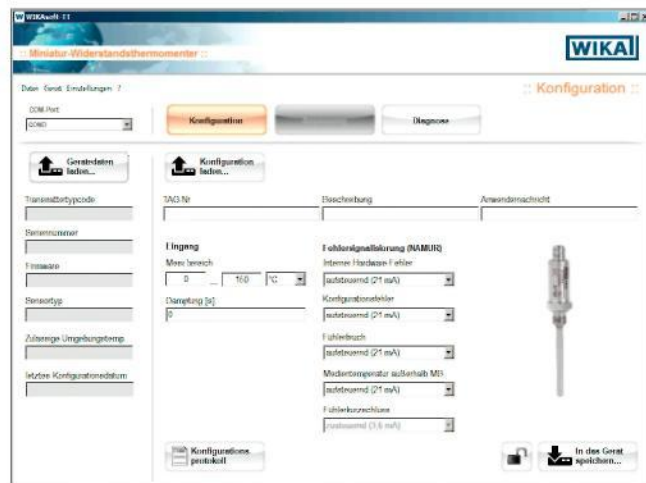

Configuration software (multilingual) as a download from www.wika.com

Connecting PU-448 programming unit

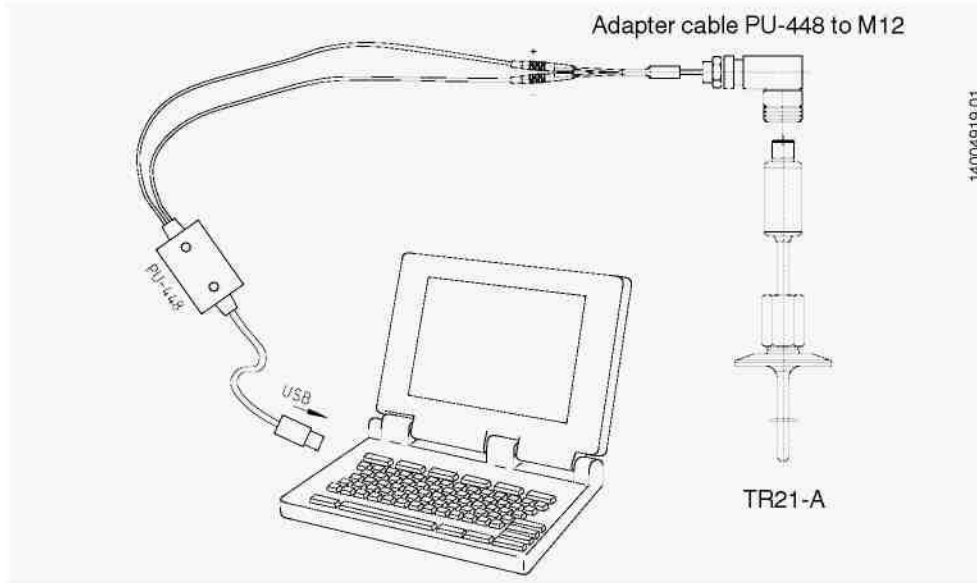

Electrical connection

Output signal 4 ... 20 mA
Circular connector M12 x 1, 4-pin

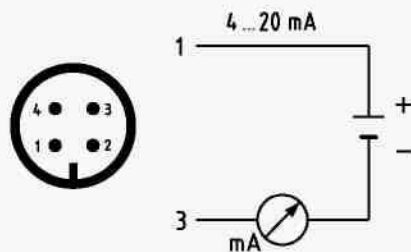

Pin	Signal	Description
1	L+	10 ... 30 V
2	VQ	not connected
3	L-	0 V
4	C	not connected

Output signal - Pt100 sensor
Circular connector M12 x 1, 4-pin

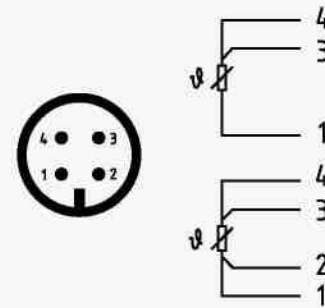

Load diagram

The permissible load depends on the loop supply voltage. For communication with the instrument with programming unit PU-448, a max. load of 350 Ω is admissible.

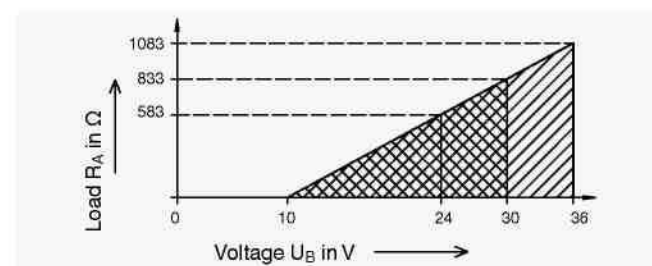

CE conformity

EMC directive ¹⁵⁾

2004/108/EC, EN 61326 emission (group 1, class B) and interference immunity (industrial application)

¹⁵⁾ Only for built-in transmitter

Patents, property rights

M12 x 1 adapter to angular connector DIN EN 175301-803, registered under No. 001370985

Approvals (option)

- **3-A**, food, USA
- **EHEDG**, food, Germany

Certificates (option)

- 2.2 test report
- 3.1 inspection certificate
- Manufacturer's declaration regarding Regulation (EC) 1935/2004
- Hygiene certificates

Approval	3-A	EHEDG
Clamp	yes	yes ¹⁷⁾
VARIVENT®	yes	yes
BioConnect®	yes	no
DIN 11851	yes ¹⁶⁾	yes ¹⁶⁾
DIN 11864-1	yes	yes
DIN 11864-2	yes	yes
DIN 11864-3	yes	yes
Welding ball	yes	no
Compression fitting	no	no
SMS	no	no

¹⁶⁾ In combination with
- ASEPTO-STAR k-flex upgrade gaskets from Kieselmann GmbH, Germany or
- SKS gasket set DIN 11851 EHEDG from Sierserna Komponenten Service (S.K.S.) B.V., Netherlands

¹⁷⁾ In combination with
- Kalrez/Stainless steel gasket from Dupont de Nemours, Switzerland or
- T-ring seals from Combit International B.V., Netherlands

Approvals and certificates, see website

Ordering information

Model / Approval / Sensor or transmitter output / Sensor specification or transmitter configuration / Process temperature / Thermowell / Process connection / Thermowell diameter / Material wetted parts / Insertion length, U₁ / Electrical accessories / Certificates / Options

© 2010 WIKA Alexander Wiegand SE & Co. KG, all rights reserved.
The specifications given in this document represent the state of engineering at the time of publishing.
We reserve the right to make modifications to the specifications and materials.

ООО ТД «АЗТЭО»
624260, Россия Свердловская область,
г. Асбест, пр. Ленина, 8/3
Тел: 8 (34365) 2-87-74, 2-45-52
Факс: 8 (34365) 2-87-74
E-mail: zakaz@azteo.ru