

Resistance thermometer For sanitary applications Model TR22-B, for orbital welding

WIKA data sheet TE 60.23



for further approvals
see page 10

Applications

- Sanitary applications
- Food and beverage industry
- Bio and pharmaceutical industry, production of active ingredients
- Paint finishing systems

Special features

- Simplified calibration through replaceable measuring inserts
- Stainless steel connection head in optimised hygienic design, easy to clean in all mounting positions (patent applied for, Patent No. GM 000984349)
- Pt100, 4 ... 20 mA or HART® protocol, FOUNDATION™ fieldbus and PROFIBUS® PA output possible
- Wetted parts from stainless steel 1.4435
- Self-draining and dead-space minimised



Resistance thermometer model TR22-B with flow-through housing for orbital welding
Options: Sealing combination at neck tube, cable gland in hygienic design

Description

The model TR22-B resistance thermometer is used for temperature measurement in sanitary applications. For an integration into the process the patented thermowell model TW61 (patent applied for, Patent No. DE 102010037994 and US 12 897.080) is directly fitted into a pipeline by means of orbital welding.

The connection ends are smooth and prepared for orbital welding. The process connections meet the stringent requirements, in terms of materials and design, of hygienic measuring points.

For easy calibration or maintenance, the sensor is removable without having to break into the process or disconnect the electrical connection. Thus hygiene risks can be minimised and downtimes can be reduced.

The spring-loaded measuring insert guarantees the contact between the sensor tip and the bottom of the thermowell and thus ensures a fast response time and high accuracy.

Specifications

Output signal Pt100

Temperature range	Measuring range -50 ... +250 °C (-58 ... +482 °F)
Measuring element/sensor (measuring current: 0.1 ... 1.0 mA)	Pt100 measuring resistor Face-sensitive Pt100 measuring resistor 1)
Connection method	1 x 3-wire 1 x 4-wire 2 x 3-wire
Sensor tolerance value 2) per IEC 60751 (class accuracy)	Class AA (1/3 DIN) Class A Class B
Response time (measurement per IEC 60751) 3)	t ₅₀ < 3.2 s t ₉₀ < 7.3 s
Measuring deviation 4)	-1 Kelvin
Measuring insert diameter	3 mm

Output signal 4 ... 20 mA, HART® protocol, FOUNDATION™ fieldbus and PROFIBUS® PA

Transmitter (selectable versions) 5)	model T19	model T24	model T32	model T53
Output				
■ 4 ... 20 mA	x	x	x	
■ HART® protocol			x	
■ FOUNDATION™ Fieldbus and PROFIBUS® PA				x
Connection method				
■ 1 x 3-wire	x	x	x	x
■ 1 x 4-wire			x	x
Measurement current	0.8 mA	0.5 mA	0.3 mA	0.2 mA
Temperature range	Measuring range -50 ... +250 °C (-58 ... +482 °F) 6), other measuring ranges are adjustable			
Response time 3)	t ₅₀ < 3.2 s t ₉₀ < 7.3 s + response time of the relevant transmitters (compare transmitter data sheet)			
Measuring deviation 4)	-1 Kelvin + accuracy of the relevant transmitters			
Measuring insert diameter	3 mm			

Thermowell model TW61 7)

Design of connection	<ul style="list-style-type: none"> ■ Flow-through housing ■ Angular housing
Nominal width of pipe	cf. table of dimensions
Surface finish	per DIN 11866 row A, B: Standard: R _a < 0.8 μm Option: R _a < 0.4 μm electropolished per DIN 11866 row C, ASME-BPE: Standard: R _a < 0.76 μm Option: R _a < 0.38 μm electropolished
Materials	others on request per DIN 11866 row A, B: stainless steel 1.4435 per DIN 11866 row C, ASME-BPE: stainless steel 316L
Connection to the thermometer	M24 x 1.5
Thermowell diameter	cf. table of dimensions
Neck tube length M	The neck tube length M is adjusted to the length A (l ₁) of 125 mm. The use of uniform measuring insert lengths even for different nominal tube sizes reduces the inventory of the measuring inserts, particularly for larger plants. Additionally, the measuring insert length is optimised for an on-site calibration, for example with a WIKA temperature dry-well calibrator model CTD9X00. further lengths to customer specifications
Pressure ratings	cf. table of dimensions
Tube length TL and L ₁ , thermowell insertion length U ₁	cf. table of dimensions

1) Face-sensitive measuring resistors, through their small design, serve to reduce the heat dissipation with short insertion lengths.

Available for the temperature range -50...+150 °C (-58 ... +302 °F) in classes A and B.

For thermowell insertion lengths of less than 11 mm, face-sensitive measuring resistors are generally used.

2) For detailed specifications for Pt100 sensors, see Technical Information IN 00.17 at www.wika.com.

3) Flow-through housing OD 26.9 mm

4) Measured at 100 °C

5) For a correct determination of the overall measuring error, both sensor and transmitter measuring deviations have to be considered.

6) The temperature transmitter should therefore be protected from temperatures over 85 °C (185 °F)

7) For TR22-B designs without thermowell, the insertion length is defined by the dimension l₁ from the lower edge of the connection head to the tip of the measuring insert (see "Dimensions of the connection head in mm"). The thickness of bottom of the thermowell can be neglected for dimensioning. It is offset by the spring travel of the measuring insert.

Options

The transition from the connection head to the thermowell is effected via an optional sealing combination (polyurethane) of flat gasket and wiper. This combination permanently prevents the penetration and depositing of humidity and impurities in this area (IP 68). Additionally, the sealing combination simplifies the cleaning process significantly.

The design of the patented BVS head (Patent No. GM 000984349) combined with the cable gland in hygienic design results in an easy to clean and hygienic measuring location, even in areas which are not in contact with the product. The BVS head is designed in such a way that cleaning agents can run off easily and that no residues can accumulate on the case.



Connection head

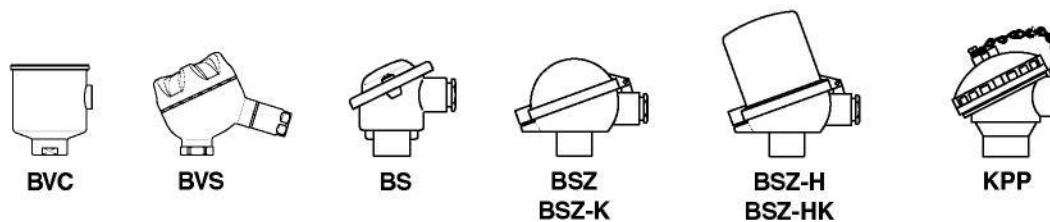

Model	Material	Cable entry	Ingress protection	Cap	Surface finish	Weight in kg
BVC	Stainless steel (1.4571)	M16 x 1.5 ¹⁾	IP 68	Flat screw cover	Metal blank	0.60
BVS	Stainless steel (1.4308)	M20 x 1.5 ¹⁾	IP 68	Screw cover, Hygienic Design	Precision casting, electropolished	0.50
BS	Aluminium	M20 x 1.5 ¹⁾	IP 65	Cap with 2 screws	Blue, lacquered ²⁾	0.14
BSZ	Aluminium	M20 x 1.5 ¹⁾	IP 65	Hinged cover with cylinder head screw	Blue, lacquered ²⁾	0.29
BSZ-K	PAV antistatic PA12	M20 x 1.5 ¹⁾	IP 65	Hinged cover with cylinder head screw	Black	0.30
BSZ-H	Aluminium	M20 x 1.5 ¹⁾	IP 65	Hinged cover with cylinder head screw	Blue, lacquered ²⁾	0.20
BSZ-HK	PAV antistatic PA12	M20 x 1.5 ¹⁾	IP 65	Hinged cover with cylinder head screw	Black	0.30
KPP	Polypropylene	M20 x 1.5	IP 65	Screw cover	White	0.16

1) Standard
2) RAL 5022

Connection head with digital indicator (option)

As an alternative to the standard connection head the thermometer can be fitted with an optional DIH10 digital indicator. The connection head used for this is similar to the model BSZ-H head. For operation, a 4 ... 20 mA transmitter is needed, which is mounted to the measuring insert. The indication range is configured identically to the measuring range of the transmitter.

Designs with ignition protection type "intrinsically safe", Ex i, are also available.



Connection head with digital indicator, model DIH10

Transmitter (optional)

Depending on the connection head used, a transmitter can be mounted within the thermometer.

- Mounted instead of terminal block
- Mounted within the cap of the connection head
- Mounting not possible

Connection head	Transmitter model			
	T19	T24	T32	T53
BVC	○	○	○	○
BVS	○	○	○	○
BS	○	○	-	○
BSZ / BSZ-K	○	○	○	○
BSZ-H / BSZ-HK	●	●	●	●
KPP	○	○	○	○

Mounting of 2 transmitters on request.

Model	Description	Explosion protection	Data sheet
T19	Analogue transmitter, configurable	without	TE 19.03
T24	Analogue transmitter, PC configurable	optional	TE 24.01
T32	Digital transmitter, HART® protocol	optional	TE 32.04
T53	Digital transmitter FOUNDATION™ Fieldbus and PROFIBUS® PA	Standard	TE 53.01

Overview of the process connections, thermowell variants

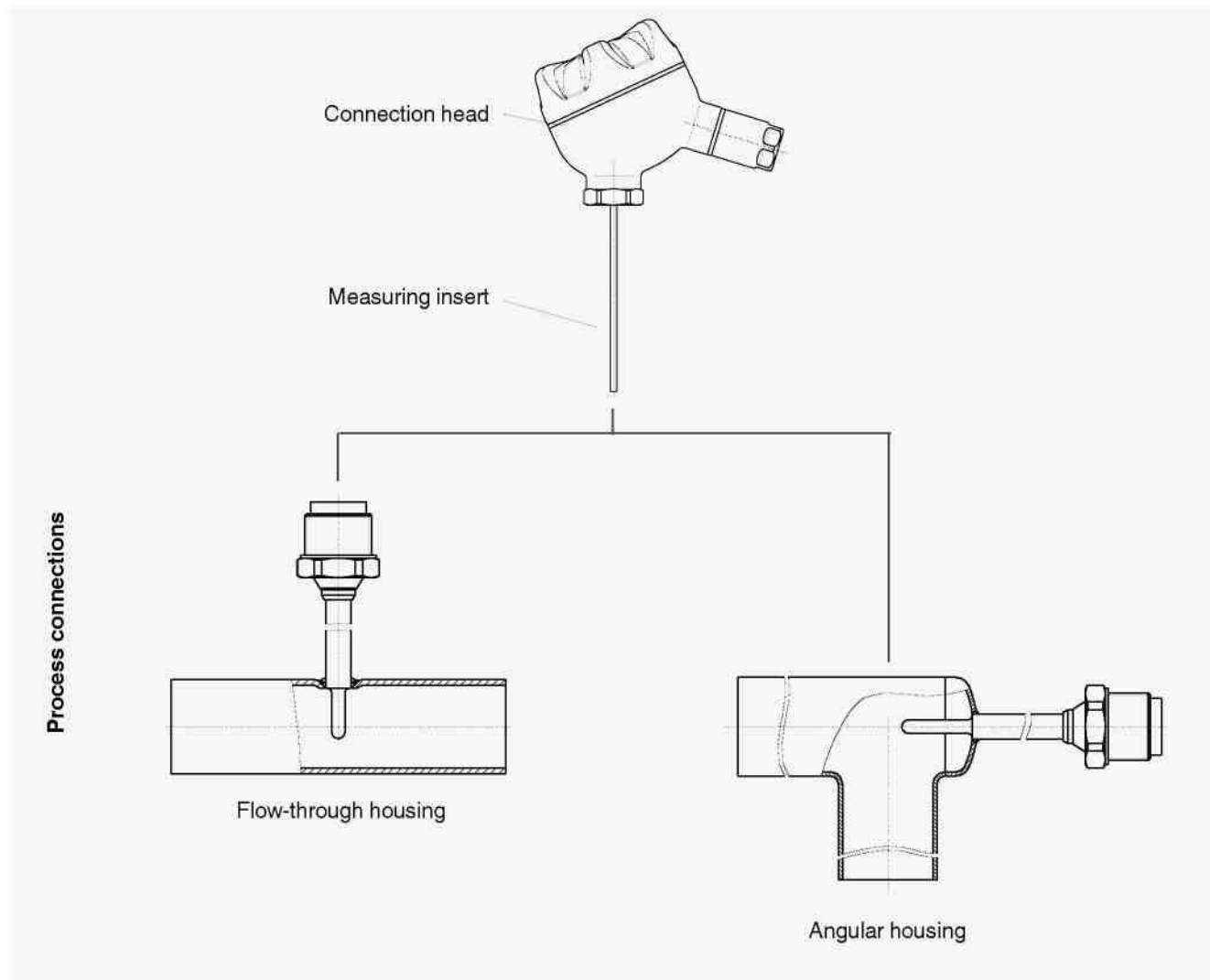

Dimensions in mm

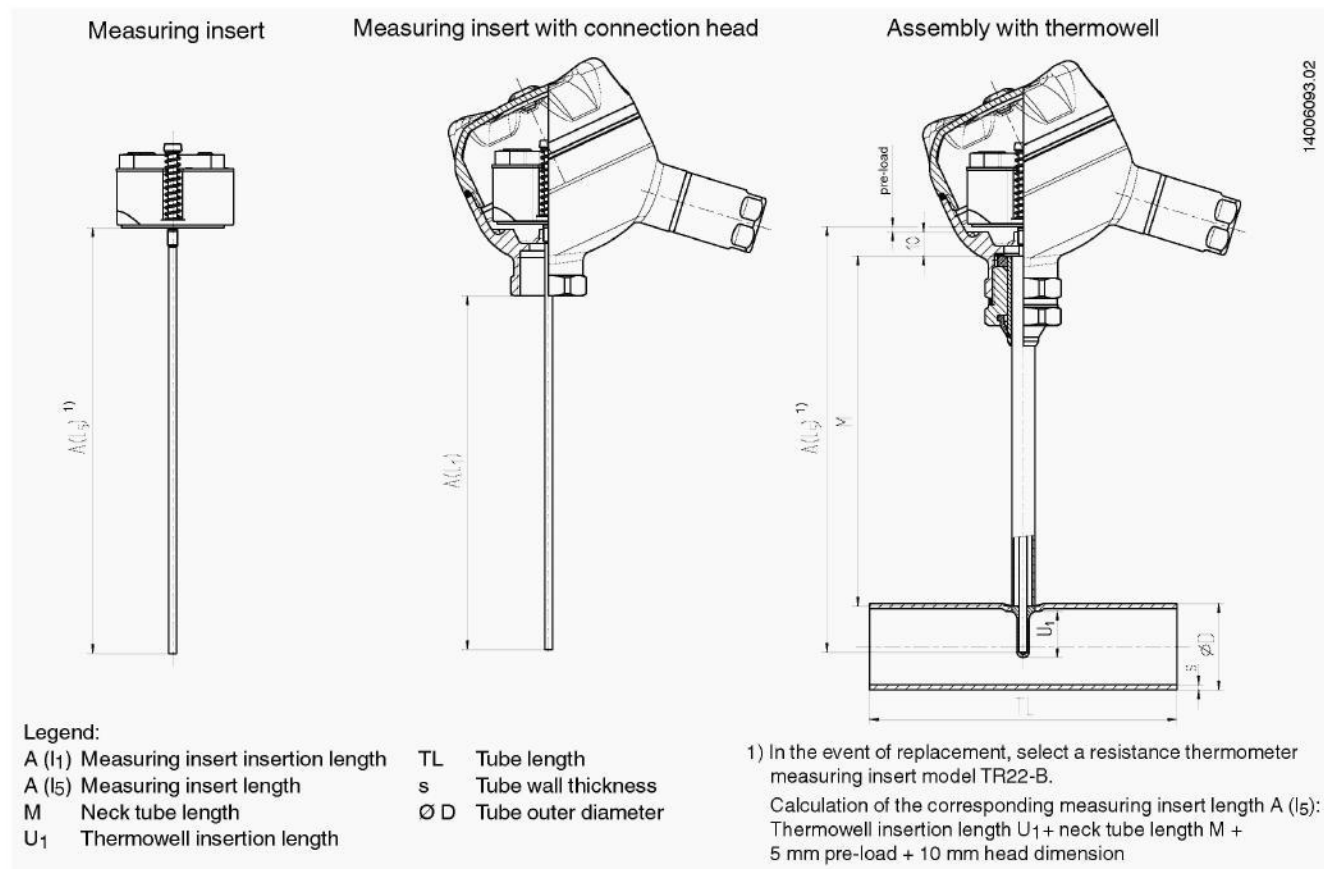

Standardisation of measuring inserts for different nominal widths of pipes

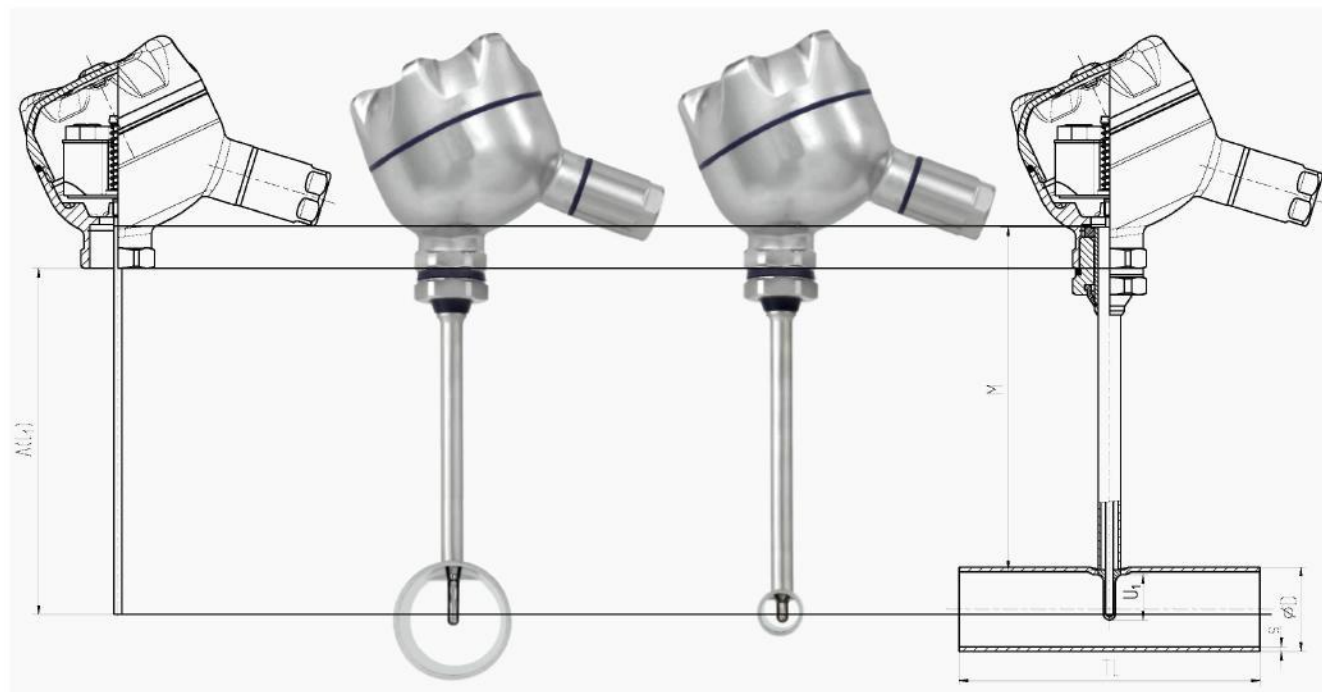

Due to the variable neck tube length M, measuring inserts with standardised insertion lengths A (l₁) can be used. Thus, variance and stocking of spare parts are minimised. At the same time, the use of correct insertion lengths in the event of replacement is ensured.

Dimensions of the connection heads in mm

Connection head model BVC

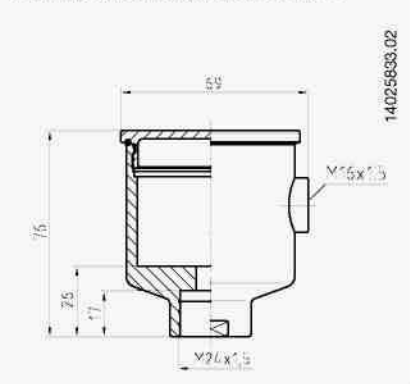

Connection head model BVS

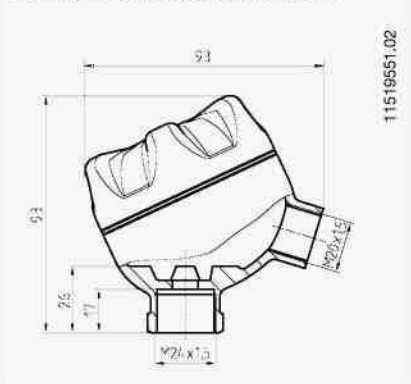

Connection head model BS

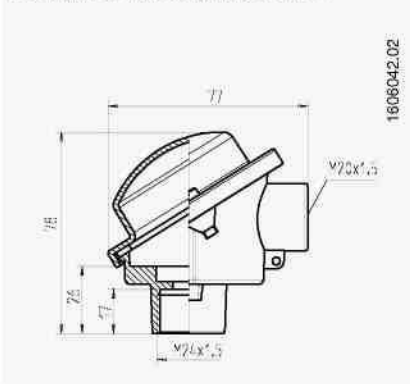

Connection head models BSZ, BSZ-K

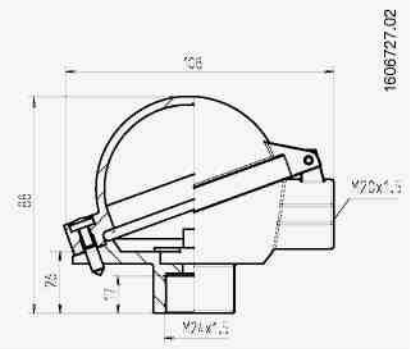

Connection head models BSZ-H, BSZ-HK

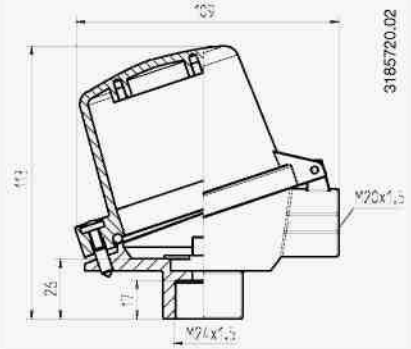

Dimensions of the process connections in mm (model TW61 thermowells)

Flow-through housing

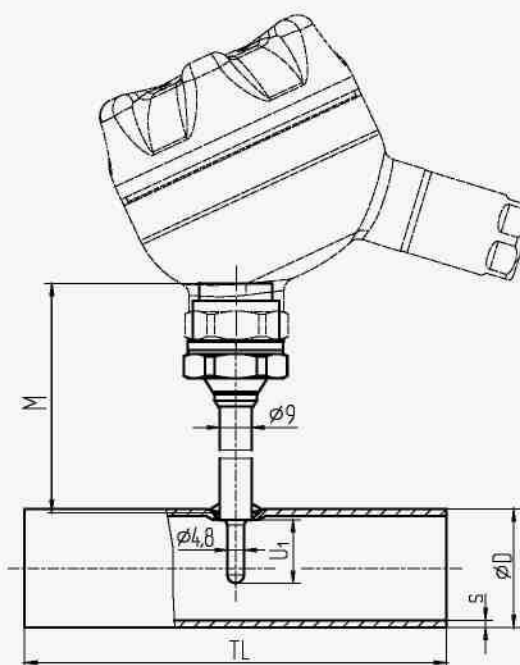
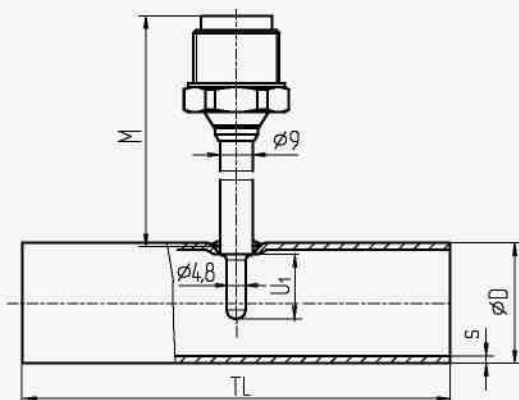

Nominal width of pipe DN / OD	Nominal pressure in bar PN	Tube outer diameter ϕD	Tube wall thickness s	Tube length T_L	Thermowell insertion length U_1	Neck tube length M
DIN 11866 row A or metric						
10	25	13	1.5	70	6	129
15	25	19	1.5	70	9	126
20	25	23	1.5	80	11	124
25	25	29	1.5	100	18	117
32	25	35	1.5	110	18	117
40	25	41	1.5	120	18	117
50	25	53	1.5	160	30	105
65	16	70	2.0	210	30	105
80	16	85	2.0	260	45	90
100	12.5	104	2.0	310	45	90
DIN 11866 row B or ISO						
13.5	25	13.5	1.6	64	6	129
17.2	25	17.2	1.6	68	9	126
21.3	25	21.3	1.6	72	11	124
26.9	25	26.9	1.6	110	11	124
33.7	25	33.7	2.0	120	18	117
42.4	25	42.4	2.0	130	18	117
48.3	25	48.3	2.0	130	18	117
60.3	25	60.3	2.0	180	30	105
76.1	16	76.1	2.0	220	30	105
88.9	16	88.9	2.3	260	45	90
DIN 11866 row C or ASME BPE						
1/2"	13.8	12.7	1.65	95.2	6	129
3/4"	13.8	19.05	1.65	101.6	9	126
1"	13.8	25.4	1.65	108.0	11	124
1 1/2"	13.8	38.1	1.65	120.6	18	117
2"	13.8	50.8	1.65	146.0	18	117
2 1/2"	13.8	63.5	1.65	158.8	30	105
3"	13.8	76.2	1.65	171.4	30	105
4"	13.8	101.6	2.11	209.6	45	90

All thermowells of the TW61 series that are internally pressurised, with a nominal diameter (DN) > 25 mm, are manufactured and tested to Module H of the Pressure Equipment Directive, 97/23/EC.

Angular housing

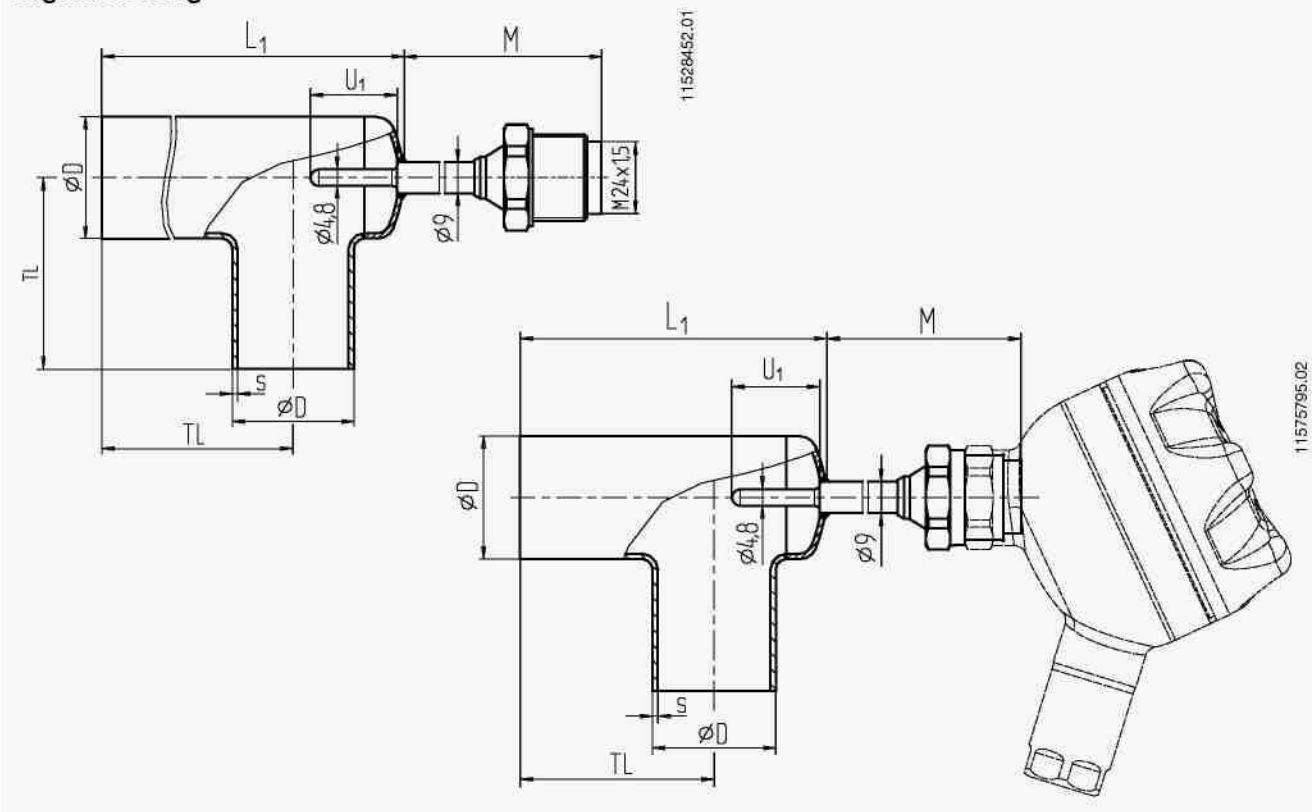

Nominal width of pipe DN / OD	Nominal pressure in bar PN	Tube outer diameter Ø D	Tube wall thickness s	Tube length		Thermowell insertion length U ₁	Neck tube length
				T _L	L ₁		
DIN 11866 row A or metric							
10	25	13	1.5	35	55	14	121
15	25	19	1.5	35	55	18	117
20	25	23	1.5	40	63	18	117
25	25	29	1.5	50	77	30	105
32	25	35	1.5	55	87	30	105
40	25	41	1.5	60	97	30	105
50	25	53	1.5	80	126	30	105
65	16	70	2.0	105	165	45	90
80	16	85	2.0	130	201	45	90
100	12.5	104	2.0	155	241	45	90
DIN 11866 row B or ISO							
13.5	25	13.5	1.6	32	55	14	121
17.2	25	17.2	1.6	34	55	16	119
21.3	25	21.3	1.6	36	58	18	117
26.9	25	26.9	1.6	55	81	30	105
33.7	25	33.7	2.0	60	91	30	105
42.4	25	42.4	2.0	65	102	30	105
48.3	25	48.3	2.0	65	108	30	105
60.3	25	60.3	2.0	90	145	45	90
76.1	16	76.1	2.0	110	173	45	90
88.9	16	88.9	2.3	130	203	45	90
DIN 11866 row C or ASME BPE							
1/2"	13.8	12.7	1.65	47.6	71	14	121
3/4"	13.8	19.05	1.65	50.8	71	18	117
1"	13.8	25.4	1.65	54.0	79	18	117
1 1/2"	13.8	38.1	1.65	60.3	94	30	105
2"	13.8	50.8	1.65	73.0	118	30	105
2 1/2"	13.8	63.5	1.65	79.4	134	45	90
3"	13.8	76.2	1.65	85.7	150	45	90
4"	13.8	101.6	2.11	104.8	190	45	90

All thermowells of the TW61 series that are internally pressurised, with a nominal diameter (DN) > 25 mm, are manufactured and tested to Module H of the Pressure Equipment Directive, 97/23/EC.

Explosion protection (option)

Resistance thermometers of the TR22-B series are available with a EC type-examination certificate for "intrinsically safe", Ex i, ignition protection.

These instruments comply with the requirements of 94/9/EC (ATEX) directive for gas and dust. Manufacturer's declarations in accordance with NAMUR NE24 are also available.

The classification/suitability of the instrument (permissible power P_{max} as well as the permissible ambient temperature) for the respective category can be seen on the EC-type examination certificate and in the operating instructions.

Built-in transmitters have their own EC-type examination certificate. The permissible ambient temperature ranges of the built-in transmitters can be taken from the corresponding transmitter approval. The system operator is responsible for using suitable thermowells.

Hygienic design

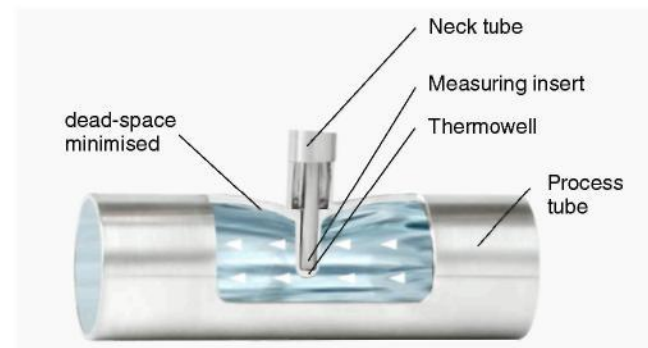

The patented (Patent No. DE 102010037994 and US 12 897.080) hygienic design of the TW61 flow-through housing enables dead-space minimised, invasive temperature measurement and, through self-draining, a flexible mounting position.

Electrical connection

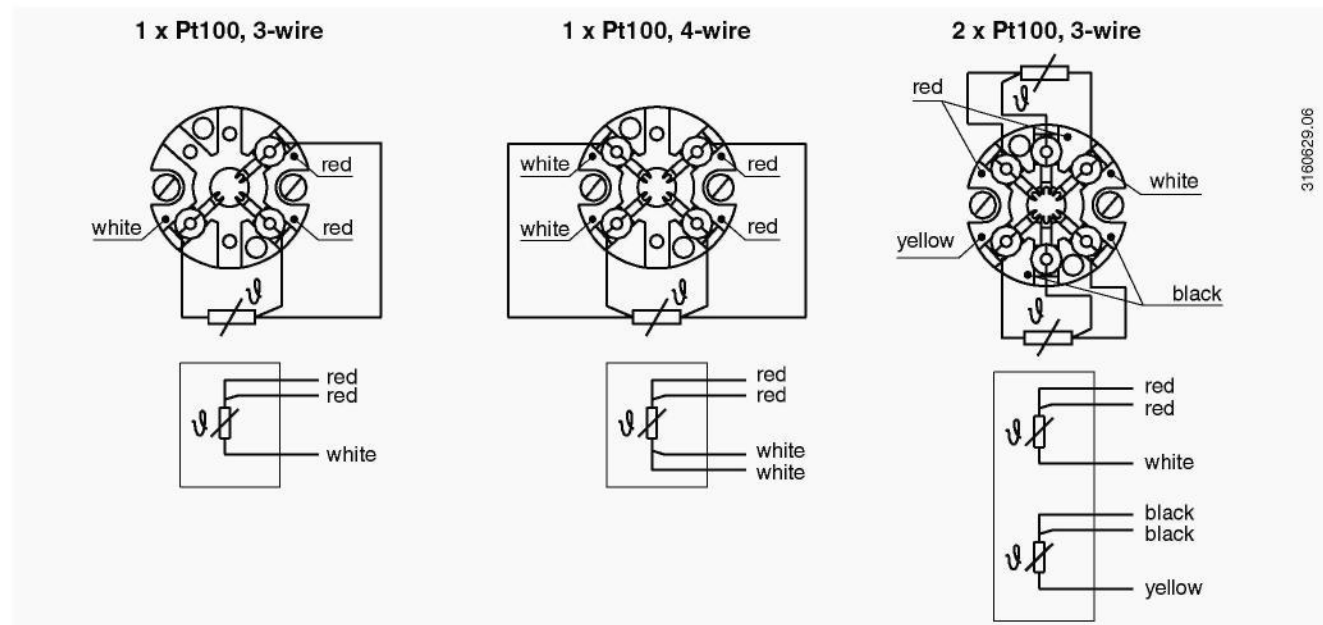

For the electrical connections of built-in temperature transmitters see the corresponding data sheets or operating instructions.

CE conformity

Pressure equipment directive

97/23/EC, PS > 200 bar, module H, pressure accessory

For thermowells > DN 25 (1") and for the associated marking on the measuring instrument or thermowell, WIKA confirms conformity with the 97/23/EC Pressure Equipment Directive in accordance with the conformity assessment procedure, module H.

For thermowells with nominal widths of \leq DN 25 (1"), an EC conformity evaluation in accordance with the Pressure Equipment Directive (PED) is not permitted and therefore, they are manufactured without CE marking in line with the applicable sound engineering practice (PED article 3, chapter 3).

EMC directive

2004/108/EC, EN 61326 emission (group 1, class B) and interference immunity (industrial application)

ATEX directive (option)

94/9/EG, EN/IEC 60079

Approvals (option)

- **IECEX**, international certification for the Ex area
- **EAC**, import certificate, customs union Russia, Belarus, Kazakhstan
- **GOST**, metrology/measurement technology, Russia
- **3-A**, food application, USA
- **KOSHA**, type of protection "i" - intrinsic safety, type of protection "iD" - dust protection by intrinsic safety, South Korea

Ordering information

Model / Explosion protection / Output signal / Sensor / Class accuracy / Temperature range / Connection head / Cable gland / Transmitter / Thermowell / Process connection (Nominal width of pipe) / Wetted-parts materials / Neck tube length / Certificates / Optional further seal combinations

© 2011 WIKA Alexander Wiegand SE & Co. KG, all rights reserved.
The specifications given in this document represent the state of engineering at the time of publishing.
We reserve the right to make modifications to the specifications and materials.

Certificates (option)

- 2.2 Test certificate
- 3.1 Acceptance test certificate
- DKD/DAkkS calibration certificate
- Hygiene certificates

Certificate	Flow-through housing	Angular housing
3-A (74-06)	yes, for all dimensions	yes, from DIN 11866 row A: DN 32 DIN 11866 row B: DN 33.7 DIN 11866 row C: DN 1 1/2"

Approvals and certificates, see website