



ГОРЕЛКИ BURNERS

Интегрированные решения для отопления
All purpose heating solutions

Компания, сертифицированная по Системе менеджмента качества UNI EN ISO 9001

F.B.R. Quality System Certified UNI EN ISO 9001

ВВЕДЕНИЕ
INTRODUCTION

_ 4

ВЫСОКИЕ ТЕХНОЛОГИИ И ОХРАНА
ОКРУЖАЮЩЕЙ СРЕДЫ

Поиск технологического совершенства – это наша основная задача. Продукция F.B.R. поступает на рынок только после тщательных исследований и испытаний, кроме того, компания уделяет особой значение теме защиты экологии и охраны окружающей среды. Наша продукция соответствует и сертифицирована по действующим нормам CE, а сама компания имеет сертификат менеджмента качества по системе ISO 9001

**F.B.R. – TECHNOLOGICAL RIGOR
AND ECOLOGICAL RESPECT**

F.B.R.'s first aim has always been research of the best in technology. Our products are only marketed after stringent trials using the latest in industry led testing procedures with respect and consideration given to any issue relating to the ecological and environmental impact. F.B.R. is qualified by the Quality Management System ISO 9001 and all our products are certified and conform to the current CE norms.

ГОРЕЛКИ ДЛЯ ДИЗЕЛЬНОГО ТОПЛИВА
LIGHT OIL BURNERS

_ 8

ГОРЕЛКИ ДЛЯ ТЯЖЕЛОГО ТОПЛИВА
HEAVY OIL BURNERS

_ 18

ГОРЕЛКИ ДЛЯ ГАЗА
GAS BURNERS

_ 26

ГОРЕЛКИ ДЛЯ ГАЗА/ДИЗЕЛЬНОГО ТОПЛИВА
ДЛЯ ГАЗА/ТЯЖЕЛОГО ТОПЛИВА KN
DUAL FUEL BURNERS
GAS/LIGHT OIL
GAS/HEAVY OIL KN

_ 38

_ 44

ПРОМЫШЛЕННЫЕ ГОРЕЛКИ
INDUSTRIAL BURNERS

_ 46



МЫ ЛОВИМ ОГОНЬ, ЧТОБЫ
ОСВОБОДИТЬ ТЕПЛО

Capturing the fire
to free heat.



Knowledge and updating
at F.B.R. Training Centre



100% MADE in ITALY



Since 1969 HIGH-TECH burners

Мы являемся идеальным партнером для монтажных организаций и фирм, которые считают Качество абсолютной ценностью.

С 1969 года проектируем и производим высокотехнологичные горелки для бытового и промышленного применения.

Консолидированный опыт компании F.B.R. в союзе с инновационным и открытым духом, позволили получить признание наших продуктов на основных международных рынках: продажа наших горелок осуществляется в 80 странах мира.

Мы постоянно проводим обучение для технических специалистов. Семинары проводит наш квалифицированный персонал в собственном специализированном Центре обучения F.B.R.

We are the ideal partner for the distributor with Quality as absolute value.

Since 1969 we have designed and manufactured high-tech burners for industrial and civil applications. In addition to the standard product range, F.B.R. also supplies high power burners and burners for alternative fuels such as biodiesel, "BTZ" (low sulfur oil) and vegetable oils (i.e. colza oil, sunflower oil).

F.B.R.'s sound experience together with an open and innovative spirit results in our products being appreciated on the principal international markets: currently our burners are distributed to 80 nations throughout the world.

The diffusion of knowledge with its continuous updating is guaranteed through specific training courses held by our qualified technicians within our own F.B.R. Training Centre.



80 Nations
all over the world

Реализация ваших идей это наша работа.

Our job is to focus on your requirements.



R&D Lab

always looking for better performance

Команда экспертов компании F.B.R., работающая в области сгорания и электроники, занята анализом и реализацией новых технологических решений, которые гарантируют отличные характеристики и высокую надежность.

В поиске лучших характеристик, наша команда извлекает все возможное из оборудования и современных программ. Мы активно используем трехмерную систему CAD, большую и хорошо оснащенную исследовательскую лабораторию и проверочные стенды, которые симулируют наиболее сложные рабочие условия. В частности, лаборатория по исследованию и развитию оснащена точными электронными инфракрасными и ультрафиолетовыми парамагнитными приборами для анализа продуктов сгорания, цифровыми многодиапазонными звукомерами, современным осциллографом, подключенным к компьютерной системе обработки данных и интегрированным многофункциональным инструментам для проверки и анализа характеристик и проведения длительных испытаний.

F.B.R. combustion and electronics experts are fully dedicated to the analysis and implementation of new technological solutions that guarantee excellence in performances and reliability.

Our Research & Development team is constantly looking to better performance using the very latest in three dimensional CAD systems and a fully equipped laboratory together with a hi-tech simulated working environment. Particularly the laboratory of research & development is equipped with precise electronic paramagnetic infrared and ultraviolet devices of combustion analysis, digital multiscale phonometries, an evolved oscilloscope interfaced to a computerized data collecting system and integrated and multifunctional tools for performance analysis and long duration testing.

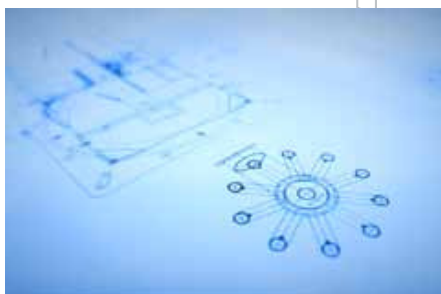

В компании F.B.R. коллектив техников-проектировщиков работает над трансформацией запросов и потребностей в конкретные и инновационные проекты. Слушать клиента и предлагать новые решения: в соответствии с его запросами осуществляется тщательное проектирование более надежных и передовых продуктов.

At F.B.R. a consolidated team of technicians and designers is committed day after day to turn the most demanding requirements and unexpressed needs into concrete and innovative projects. Listening to the Client and proposing new solutions: on this premise we develop the accurate designing of products to be even more reliable and up-to-date.

Customized design



ГОРЕЛКИ ДЛЯ ДИЗЕЛЬНОГО ТОПЛИВА
LIGHT OIL BURNERS

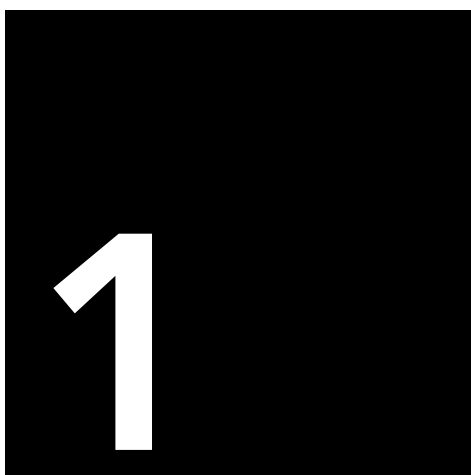



ОДНОСТУПЕНЧАТЫЕ 1 STAGE	kg/h		kW		⚡
	min	max	min	max	
G 0S 2001/2003* - G 0H 2001	2	3,3	23,7	39,1	1F
G 0SR 2001/2003* - G 0HR 2001	1,2	3,1	14,2	36,7	
G 1S 2001/2003* - G 1H 2001 - G 1R 2001/2003*	2	5	23,7	59,2	
G 2S MAXI* - G 2H MAXI	4	9,8	47,3	116	
G X3S - G X3H	7	15	83	178	
G X4S - G X4H	10	20	118	236	
G X5S - G X5H	12	30	142	355	

* Имеются также в версии Low Nox
* Available also in Low NOx version

ТЕПЛОВОЙ РАСХОД / РАЗМЕРЫ (мм) - FIRING RATES / OVERALL DIMENSIONS (mm)

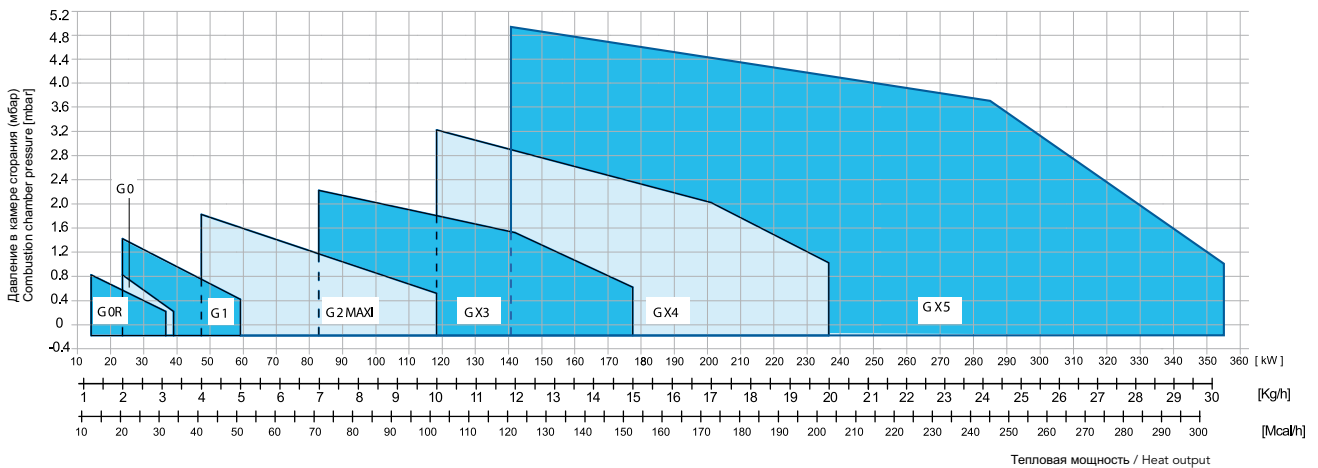
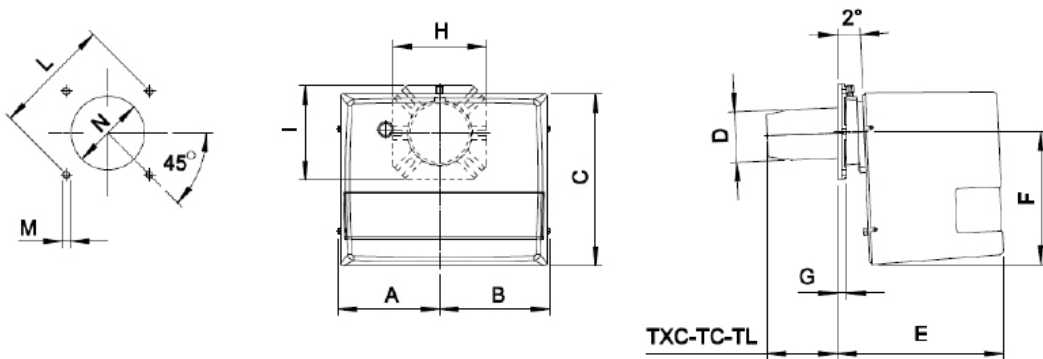

МОДЕЛЬ MODEL	* советоваи/Suggested ** TXC = 77																	
	A	B	C	D	E	F	G	H	I	L min	L *	L max	M	N min	N *	N max	TC	TL
G 0... 2001	137	137	240	80	223	169	15	150	150	130	150	170	M8	90	110	130	112	152
G 0...2003 **	137	137	240	83	223	169	15	150	150	130	150	170	M8	90	110	130	112	152
G 1... 2001	157	170	275	80	265	210	15	150	150	130	150	170	M8	90	110	130	112	152
G 1...2003	157	170	275	83	265	210	15	150	150	130	150	170	M8	90	110	130	112	152
G 2...MAXI	157	170	275	90	265	210	15	150	150	130	150	170	M8	100	110	130	107	147
G X3...	182	192	318	110	306	248	17	200	200	160	170	226	M10	120	130	140	130	250
G X4...	182	192	318	124	306	248	17	200	200	170	205	226	M10	130	140	160	130	250
G X5...	210	218	400	130	461	310	18	200	200	205	220	226	M10	140	150	180	215	335



СЕРИЯ G

ДВУХСТУПЕНЧАТАЯ С ПЕРЕПАДОМ ДАВЛЕНИЯ ОТ 23 ДО 355 кВт
2 stage with jump of pressure from 23 up to 355 kW



ДВУХСТУПЕНЧАТАЯ С ПЕРЕПАДОМ ДАВЛЕНИЯ 2 STAGE WITH JUMP OF PRESSURE	kg/h		kW		1F
	min	max	min	max	
G 1.22 2001	2	5	23,7	59,2	
G 2.22 MAXI*	4	9,8	47,3	116	
G X 3.22	7	15	83	178	
G X 4.22	10	20	118	236	
G X 5.22	12	30	142	355	

* Имеются также в версии Low Nox
* Available also in Low NOx version

ТЕПЛОВОЙ РАСХОД / РАЗМЕРЫ (мм) - FIRING RATES / OVERALL DIMENSIONS (mm)

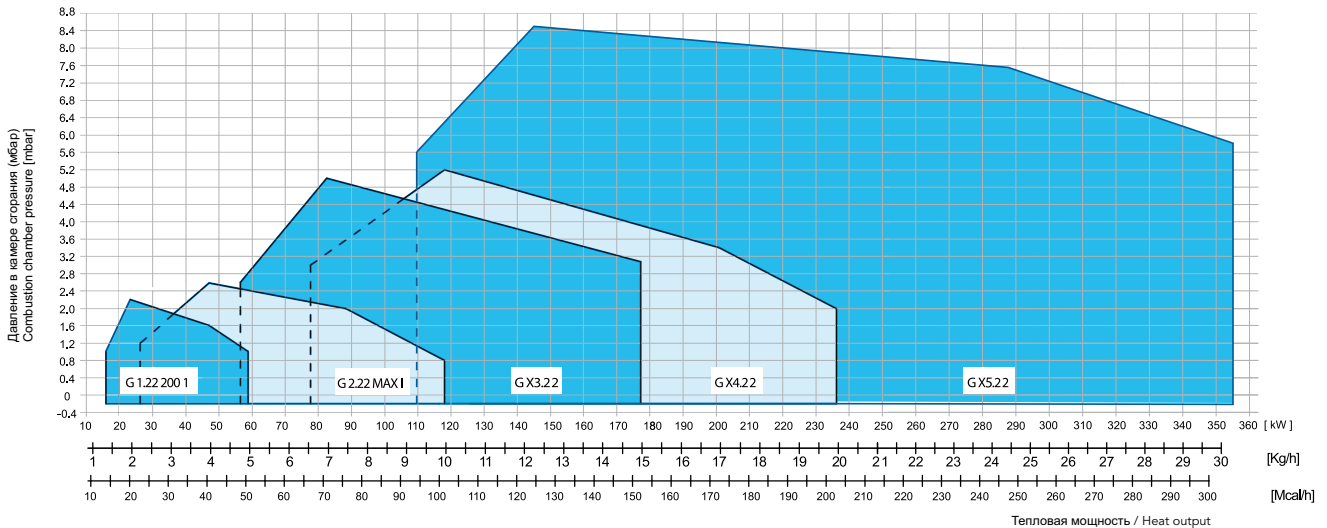
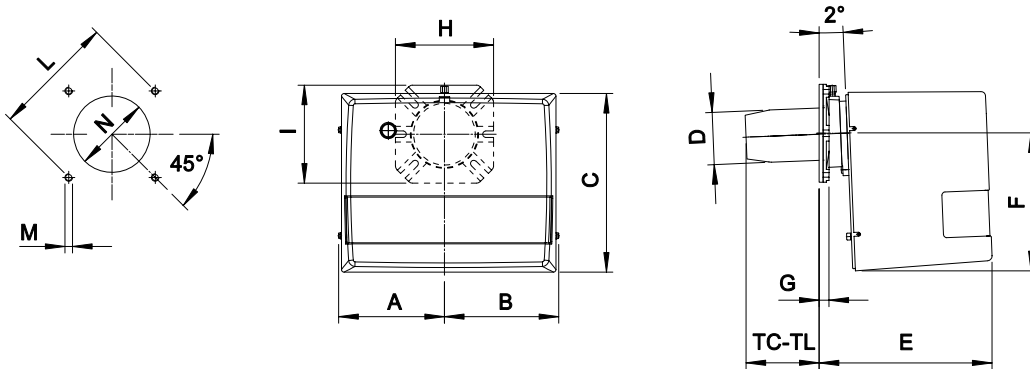

МОДЕЛЬ MODEL	* советовав/Suggested																	
	A	B	C	D	E	F	G	H	I	L min	L*	L max	M	N min	N*	N max	TC	TL
G 1.22 2001	157	170	275	80	265	210	15	150	150	130	150	170	M8	90	110	130	112	152
G 2.22 MAXI	157	170	275	90	265	210	15	150	150	130	150	170	M8	100	110	130	107	147
G X 3.22	182	192	318	110	306	248	17	200	200	160	170	226	M10	120	130	140	130	250
G X 4.22	182	192	318	124	306	248	17	200	200	170	205	226	M10	130	140	160	130	250
G X 5.22	210	218	400	130	461	310	18	200	200	205	220	226	M10	140	150	180	215	335

СЕРИЯ G/F

ОДНОСТУПЕНЧАТЫЕ для хлебопекарных печей ОТ 23 ДО 355 кВт
1 stage for bakery ovens from 23 up to 355 kW



ОДНОСТУПЕНЧАТЫЕ для хлебопекарных печей 1 STAGE for bakery ovens	kg/h		kW		⚡
	min	max	min	max	
G 1 F 2001	2	5	23,7	59,2	1F
G 2 F MAXI	4	9,8	47,3	116	
G X3 F	7	15	83	178	
G X4 F	10	20	118	236	
G X5 F	12	30	142	355	

ТЕПЛОВЫЙ РАСХОД / РАЗМЕРЫ (мм) - FIRING RATES / OVERALL DIMENSIONS (mm)

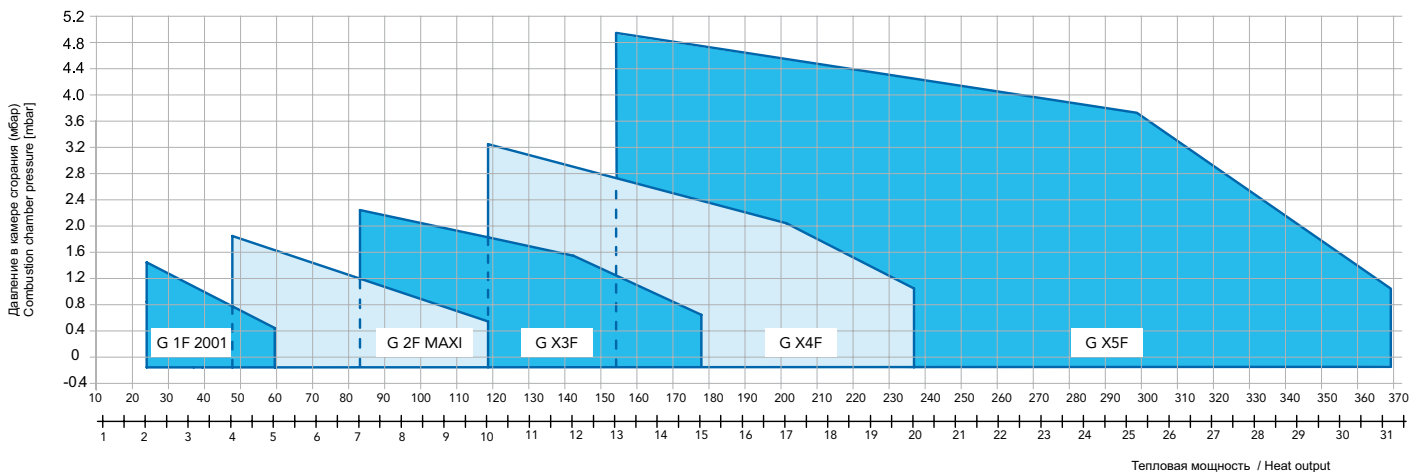
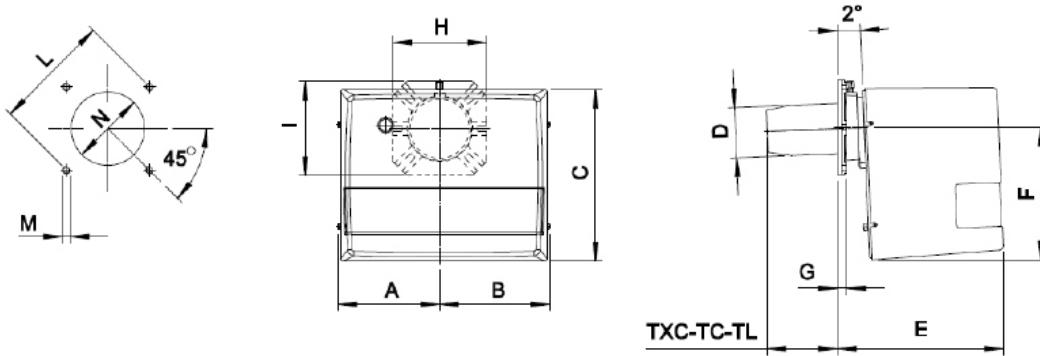

МОДЕЛЬ MODEL	* советовав/Suggested																	
	A	B	C	D	E	F	G	H	I	L min	L *	L max	M	N min	N *	N max	TC	TL
G 1 F	157	170	275	80	265	210	15	150	150	130	150	170	M8	90	110	130	112	152
G 2 F MAXI	157	170	275	90	265	210	15	150	150	130	150	170	M8	100	110	130	107	147
G X3 F	182	192	318	110	306	248	17	200	200	160	170	226	M10	120	130	140	130	250
G X4 F	182	192	318	124	306	248	17	200	200	170	205	226	M10	130	140	160	130	250
G X5 F	210	218	400	130	461	310	18	200	200	205	220	226	M10	140	150	180	215	335



ДВУХСТУПЕНЧАТЫЕ 2 STAGES	kg/h		kW		1F
	min	max	min	max	
GX 4/2	12	25	142	296	
GX 5/2	15	35	178	415	

ТЕПЛОВОЙ РАСХОД / РАЗМЕРЫ (мм) - FIRING RATES / OVERALL DIMENSIONS (mm)

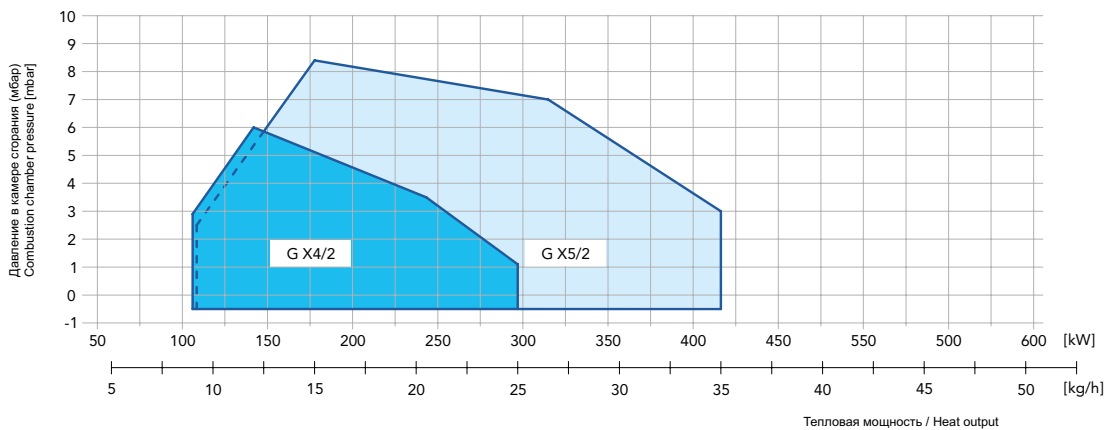
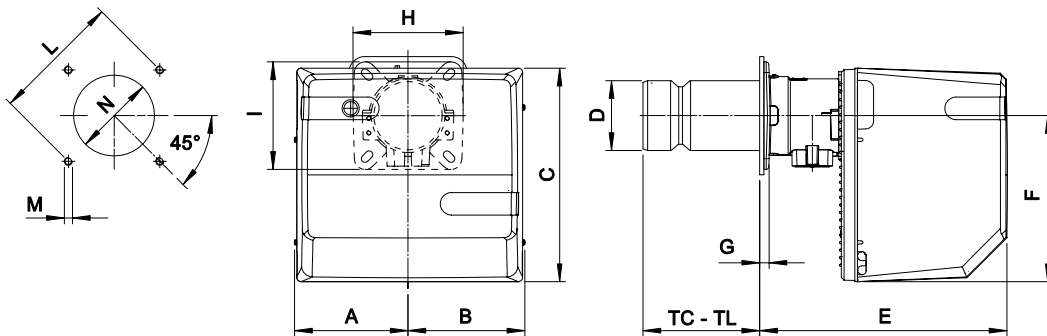

МОДЕЛЬ MODEL	* советоваи/Suggested																	
	A	B	C	D	E	F	G	H	I	L min	L*	L max	M	N min	N*	N max	TC	TL
G X4/2	182	192	318	124	306	248	17	200	200	170	205	226	M10	130	140	160	130	250
G X5/2	210	218	400	130	461	310	18	200	200	205	220	226	M10	140	150	180	215	335

СЕРИЯ FGP

ДВУХСТУПЕНЧАТЫЕ ОТ 237 ДО 1740 кВт / 2 stages from 237 up to 1740 kW



ДВУХСТУПЕНЧАТЫЕ 2 STAGES	kg/h		kW		⚡
	min	max	min	max	
FGP 50/2	20	50	237	592	3F
FGP 70/2	35	70	406	812	
FGP 100/2	40	100	464	1160	
FGP 120/2	60	120	696	1392	
FGP 150/2	75	150	870	1740	

ТЕПЛОЙ РАСХОД / РАЗМЕРЫ (мм) - FIRING RATES / OVERALL DIMENSIONS (mm)

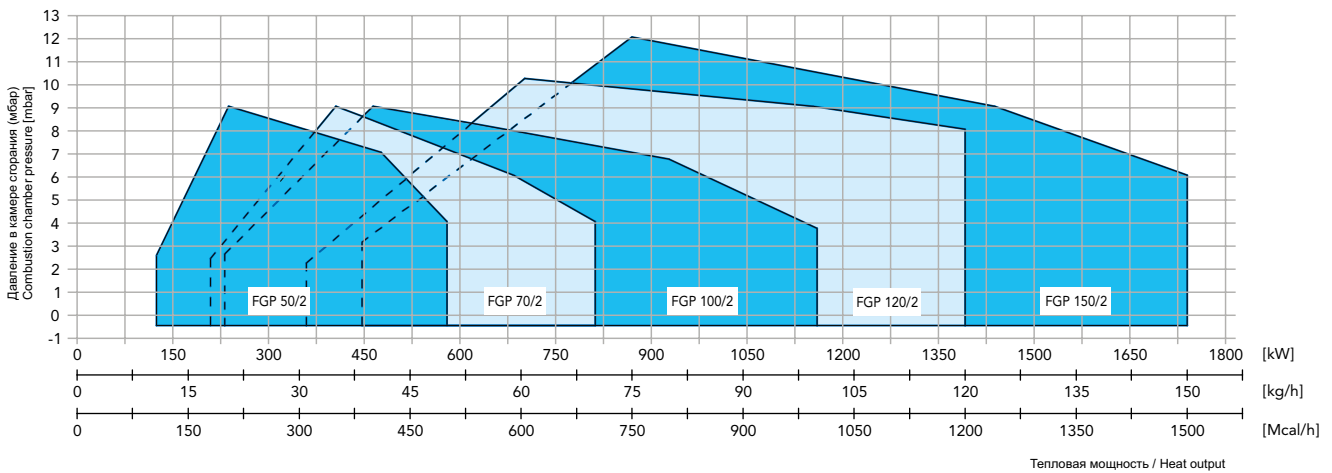
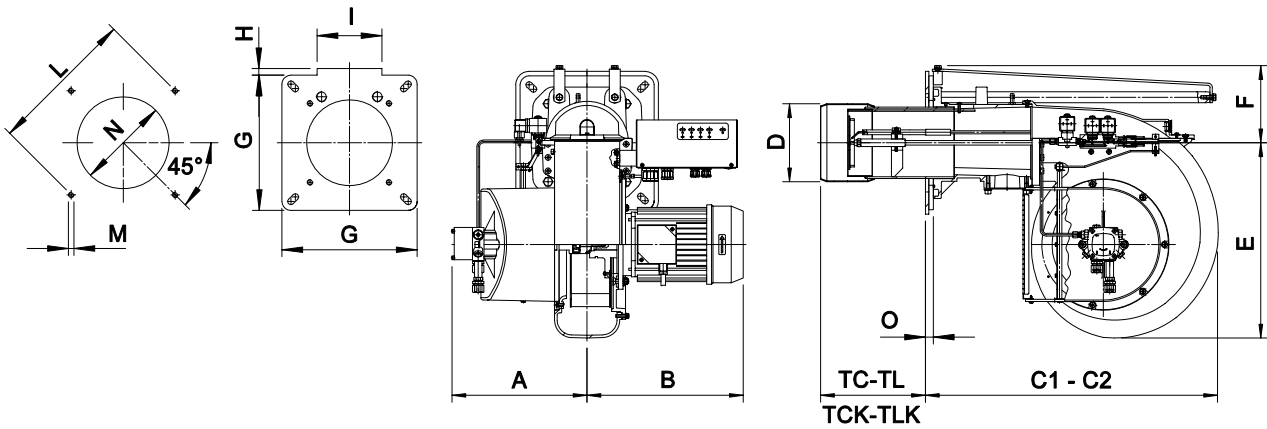

* советовавал/Suggested

C2= размер при отведенной назад горелке
C2= overall dimension with the burner out in position of maintenance

МОДЕЛЬ MODEL	A	B	C1	C2	D	E	F	G	H	I	L min	L max	M	N min*	N max	O	TC	TCK	TLK	TL
FGP 50/2	188	324	493	-	150	327	100	200	0	0	205	226	M10	160	180	18	250	-	-	335
FGP 70/2	250	310	660	1060	165	327	171	300	10	144	310	368	M12	180	250	18	-	250	-	335
FGP 100/2	300	350	670	1170	175	438	173	300	0	0	340	368	M12	190	250	18	-	235	370	-
FGP 120/2	350	380	820	1400	212	438	213	320	40	183	340	368	M14	230	250	23	200	-	-	400
FGP 150/2	350	380	820	1400	212	438	213	320	40	183	340	367	M14	230	250	23	200	-	-	400



СЕРИЯ FGP

ПРОГРЕССИВНЫЕ И МОДУЛИРУЮЩИЕ ОТ 237 ДО 1740 кВт
Progressive and modulating from 237 up to 1740 kW



ПРОГРЕССИВНЫЕ И МОДУЛИРУЮЩИЕ PROGRESSIVE & MODULATING

	kg/h		kW		3F
	min	max	min	max	
FGP 50/M	20	50	237	592	
FGP 70/M	35	70	406	812	
FGP 100/M	40	100	464	1160	
FGP 120/M	60	120	696	1392	
FGP 150/M	75	150	870	1740	

ТЕПЛОВОЙ РАСХОД / РАЗМЕРЫ (мм) - FIRING RATES / OVERALL DIMENSIONS (mm)

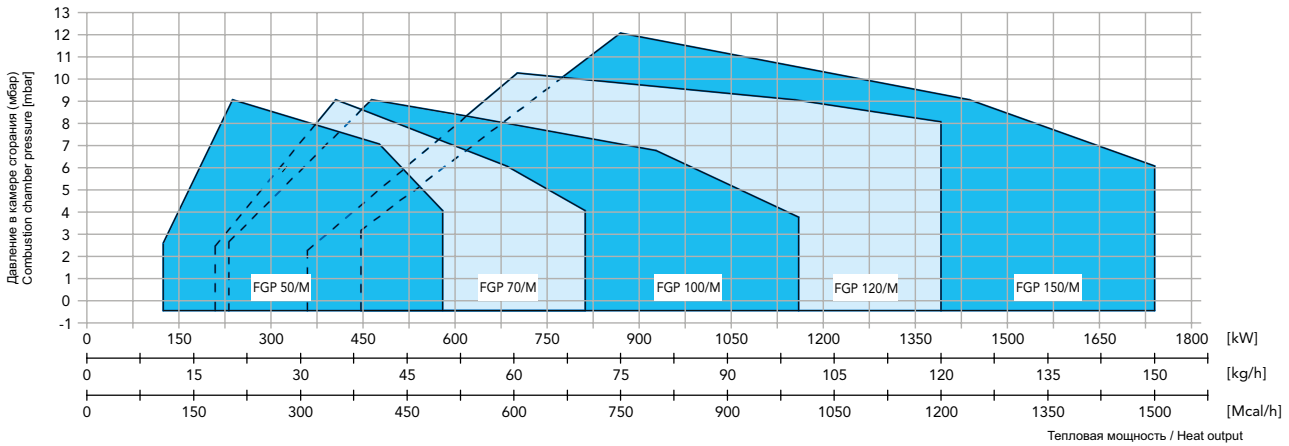
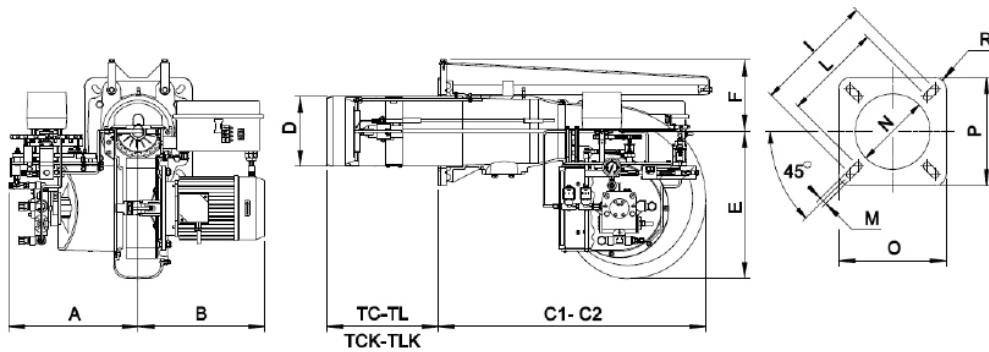

МОДЕЛЬ MODEL	A	B	C1	C2	D	E	F	I	L	M	N	O	P	R	TC	TCK	TL	TLK	C2= размер при отведенной назад горелке C2= overall dimension with the burner out in position of maintenance	
																			TC	TCK
FGP 50/M	350	305	530	-	150	327	145	226	205	M10	160	220	220	R30	250	-	335	-	-	-
FGP 70/M	350	310	700	1140	165	327	171	368	340	M12	180	320	320	R20	-	250	335	-	-	-
FGP 100/M	386	375	651	1150	175	438	173	368	340	M12	190	320	320	R20	-	235	-	370	-	-
FGP 120/M	386	376	815	1395	209	438	213	368	340	M14	230	320	320	R20	200	-	400	-	-	-
FGP 150/M	386	397	815	1395	209	438	213	368	340	M14	230	320	320	R20	200	-	400	-	-	-



ТРЕХСТУПЕНЧАТЫЕ 3 STAGES	kg/h		kW		⚡
	min	max	min	max	
FGP 190/3	60	206	700	2390	3F
FGP 250/3	80	250	930	2900	
FGP 350/3	140	350	1620	4060	
FGP 450/3	160	450	1850	5220	

ТЕПЛОВЫЙ РАСХОД / РАЗМЕРЫ (мм) - FIRING RATES / OVERALL DIMENSIONS (mm)

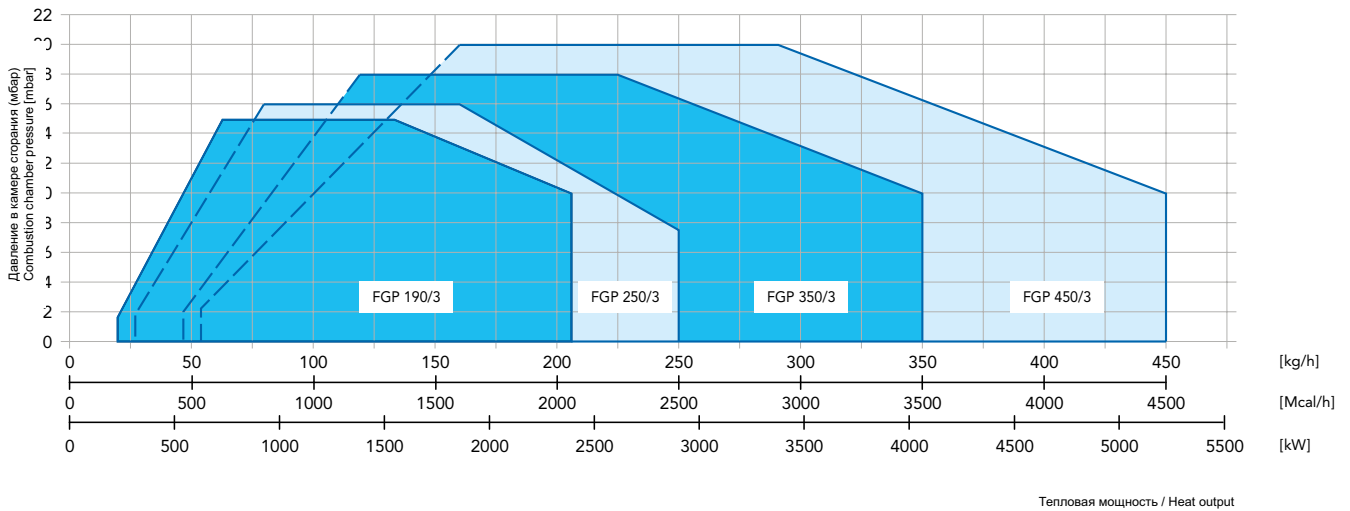
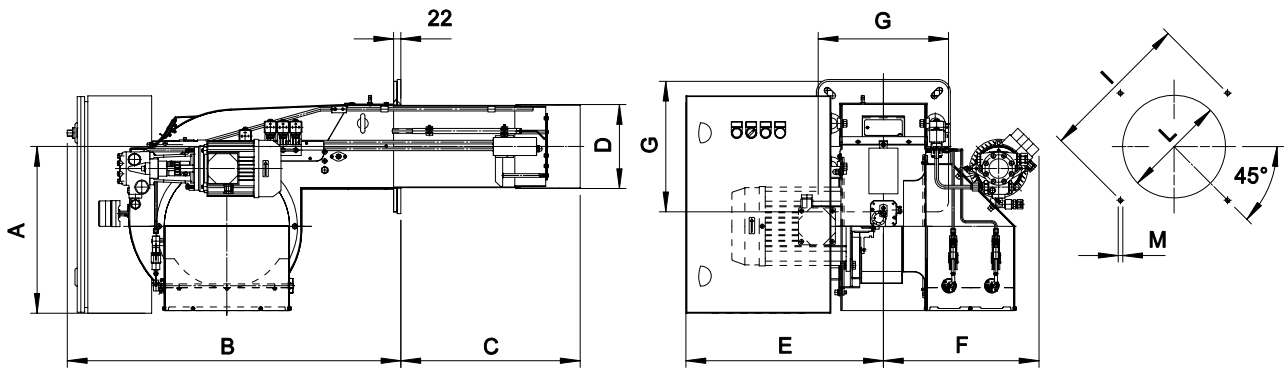

МОДЕЛЬ MODEL	* советовавал/Suggested													
	A	B	C	D	E	F	G	I min	I *	I max	L min	L *	L max	M
FGP 190/3	453	920	495	234	545	429	360	396	424	438	245	280	320	M14
FGP 250/3	453	920	500	271	545	460	360	396	424	438	280	280	320	M14
FGP 350/3	481	1090	535	334	600	517	490	552	552	580	350	350	450	M14
FGP 450/3	481	1090	560	380	600	517	490	552	552	580	390	390	450	M14



ПРОГРЕССИВНЫЕ И МОДУЛИРУЮЩИЕ
PROGRESSIVE & MODULATING

	kg/h		kW		3F
	min	max	min	max	
FGP 190/M *	60	206	700	2390	
FGP 250/M *	80	250	930	2900	
FGP 350/M *	140	350	1620	4060	
FGP 450/M *	160	450	1850	5220	
FGP 550/M *	200	550	2320	6380	

ТЕПЛОВОЙ РАСХОД / РАЗМЕРЫ (мм) - FIRING RATES / OVERALL DIMENSIONS (mm)

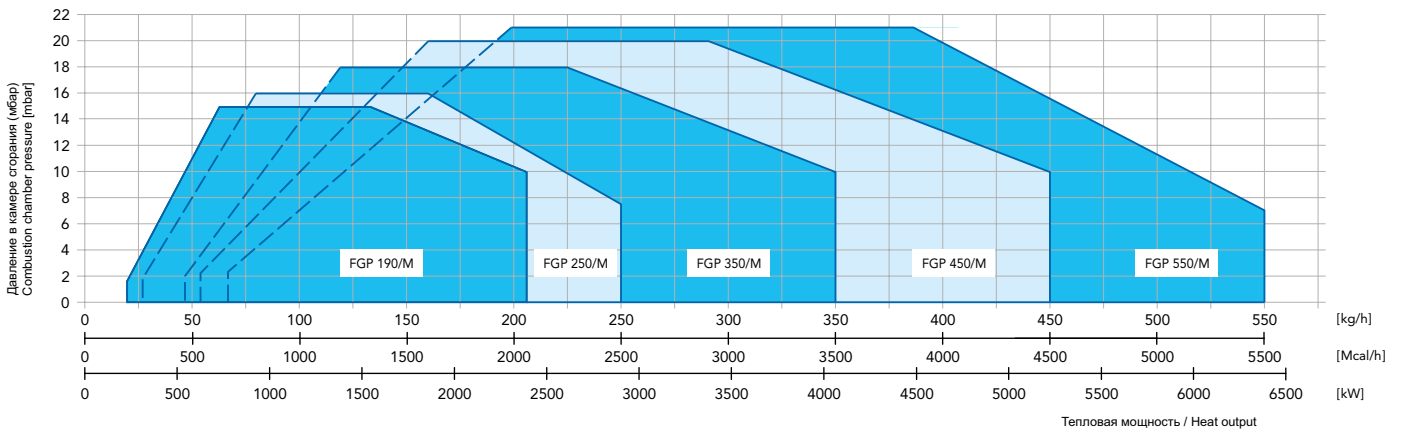
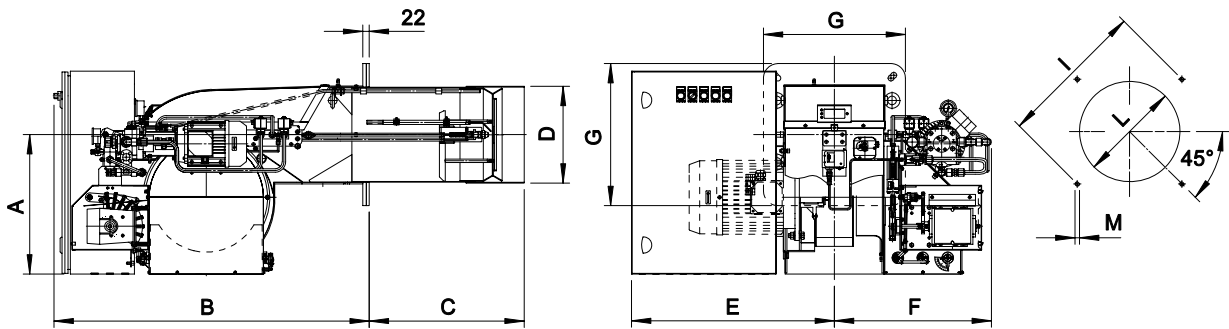



МОДЕЛЬ MODEL	* советовав/Suggested													
	A	B	C	D	E	F	G	I min	I *	I max	L min	L *	L max	M
FGP 190/M	453	920	495	234	545	530	360	396	424	438	245	280	320	M14
FGP 250/M	453	920	500	271	545	530	360	396	424	438	280	280	320	M14
FGP 350/M	481	1090	535	334	600	540	490	552	552	580	350	350	450	M14
FGP 450/M	481	1090	560	380	600	540	490	552	552	580	390	390	450	M14
FGP 550/M	481	1090	560	380	600	540	490	552	552	580	390	410	450	M14

СЕРИЯ FGP

ПРОГРЕССИВНЫЕ И МОДУЛИРУЮЩИЕ ОТ 3488 ДО 17445 кВт
Progressive and modulating from 3488 up to 17445 kW



ПРОГРЕССИВНЫЕ И МОДУЛИРУЮЩИЕ PROGRESSIVE & MODULATING	kg/h 		kW 		3F
	min	max	min	max	
FGP 650/M *	300	650	3488	7558	
FGP 750/M *	340	750	4000	8721	
FGP 1000/M *	340	1000	4000	11628	
FGP 1150/M *	353	1128	4186	13372	
FGP 1300/M *	353	1274	4186	15116	
FGP 1500/M *	500	1500	5815	17445	

* Поставляются также версии с ИНВЕРТОРОМ и ЭЛЕКТРОННЫМ КУЛАЧКОМ
* Available also versions with INVERTER and ELECTRONIC BURNER CONTROL

ТЕПЛОВОЙ РАСХОД / РАЗМЕРЫ (мм) - FIRING RATES / OVERALL DIMENSIONS (mm)

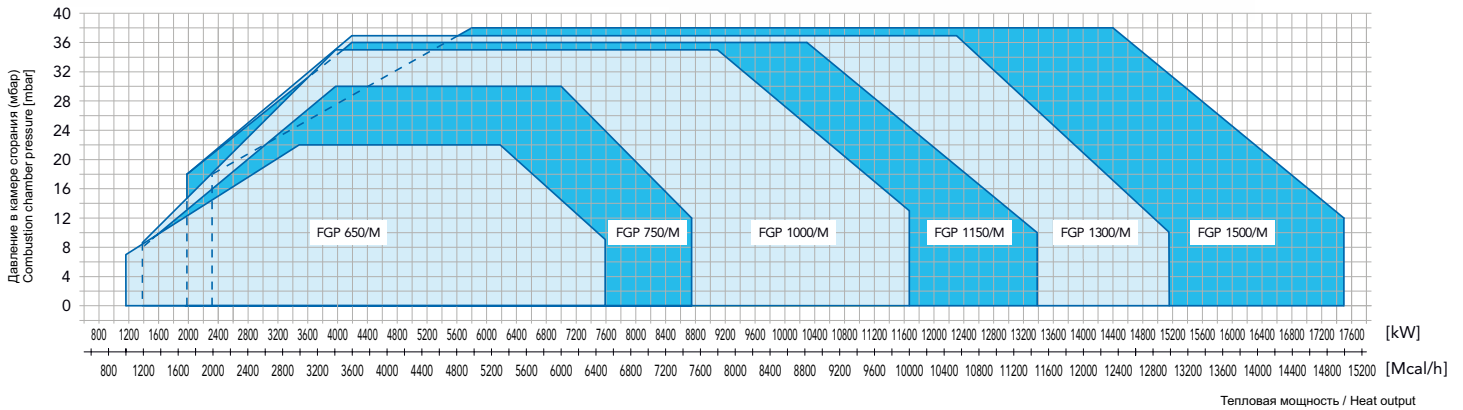

Please contact our Technical & Sales Offices for detailed technical data.

ГОРЕЛКИ ДЛЯ ТЯЖЕЛОГО ТОПЛИВА
HEAVY OIL BURNERS



СЕРИЯ FNL – FNDL

ОДНОСТУПЕНЧАТЫЕ ОТ 57 ДО 284 кВт / 1 stage from 57 up to 284 kW



ОДНОСТУПЕНЧАТЫЕ для жидкого тяжелого топлива 1 STAGE for fluid heavy oil	ОДНОСТУПЕНЧАТЫЕ для вязкого тяжелого топлива 1 STAGE for dense heavy oil	kg/h		kW		
		min	max	min	max	
FNL 8	FNDL 8	5	8	57	91	1F
FNL 16	FNDL 16	7	16	80	182	
FNL 25	FNDL 25	12,5	25	142	284	3F

ТЕПЛОВОЙ РАСХОД / РАЗМЕРЫ (мм) - FIRING RATES / OVERALL DIMENSIONS (mm)

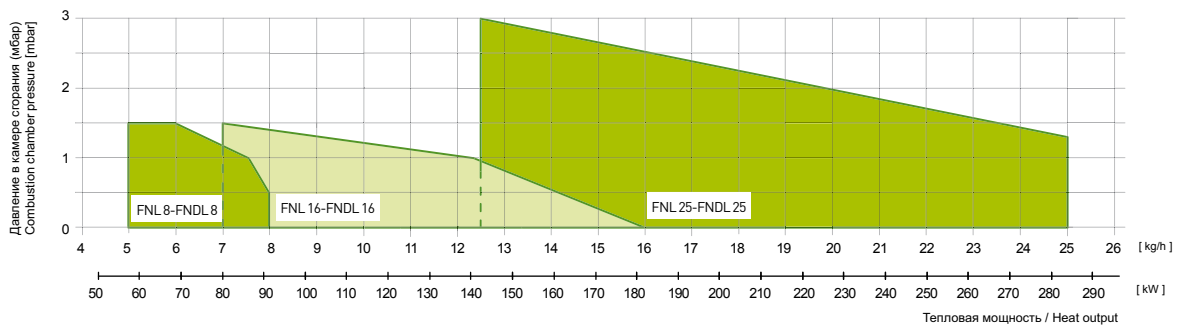
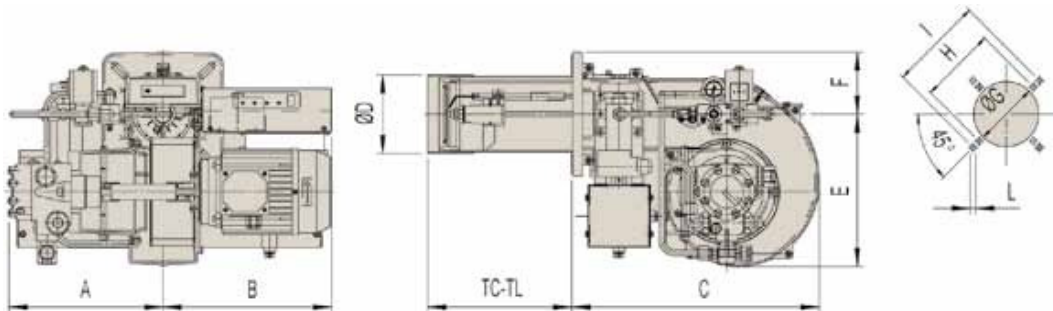

МОДЕЛЬ / MODEL		A	B	C	D	E	F	G	H	I	L	TC	TL
FNL 8	FNDL 8	253	294	410	107	251	102	120	180	226	M10	110	230
FNL 16	FNDL 16	253	294	410	107	251	102	120	180	226	M10	110	230
FNL 25	FNDL 25	255	294	410	130	251	102	140	180	226	M10	120	240



СЕРИЯ FNP – FNDP

ДВУХСТУПЕНЧАТЫЕ ОТ 142 ДО 1705 кВт / 2 stages from 142 up to 1705 kW



ДВУХСТУПЕНЧАТЫЕ для жидкого тяжелого топлива 2 STAGES for fluid heavy oil	ДВУХСТУПЕНЧАТЫЕ для вязкого тяжелого топлива 2 STAGES for dense heavy oil	kg/h		kW		3F
		min	max	min	max	
FNP 25/2	FNDP 25/2	12,5	25	142	284	
FNP 45/2	FNDP 45/2	20	45	227	512	
FNP 70/2	FNDP 70/2	35	70	398	796	
FNP 100/2	FNDP 100/2	40	100	455	1137	
FNP 125/2	FNDP 125/2	60	125	682	1421	
FNP 150/2	FNDP 150/2	70	150	796	1705	

ТЕПЛОВОЙ РАСХОД / РАЗМЕРЫ (мм) - FIRING RATES / OVERALL DIMENSIONS (mm)

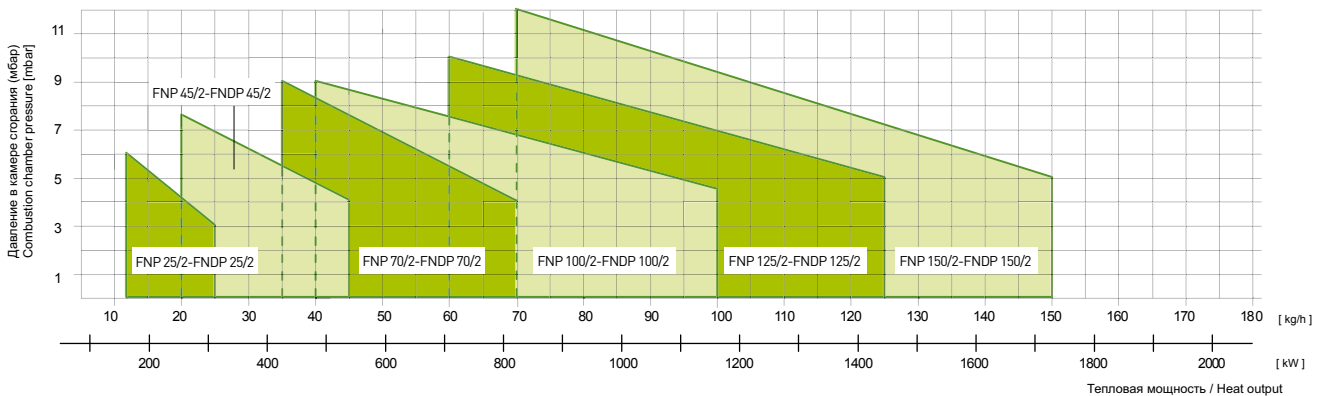
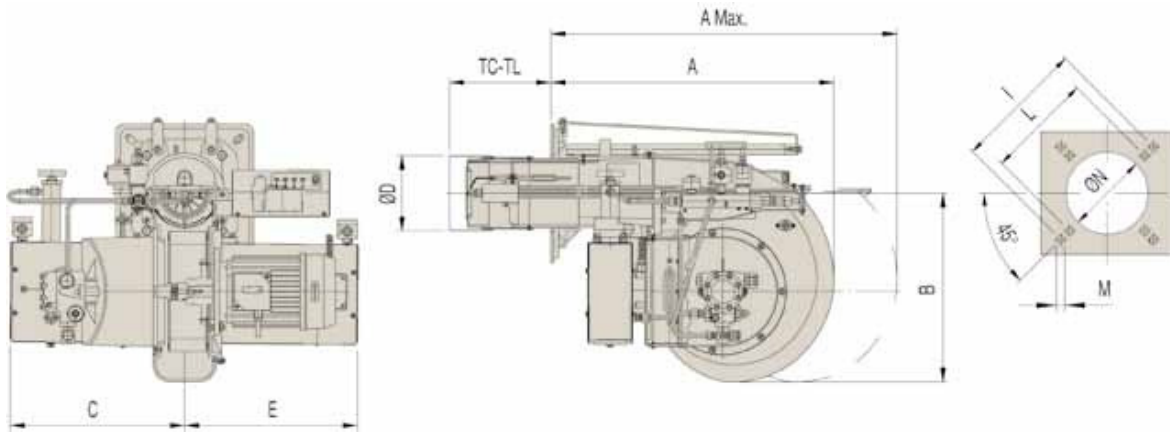

МОДЕЛЬ MODEL		A	A Max.	B	C	D	E	TC	TL	I	L	M	N
FNP 25/2	FNDP 25/2	540	950	325	295	135	319	170	350	340	283	M12	145
FNP 45/2	FNDP 45/2	540	950	325	295	155	319	170	350	340	283	M12	160
FNP 70/2	FNDP 70/2	660	1100	355	295	165	326	250	350	368	340	M12	180
FNP 100/2	FNDP 100/2	656	1085	440	410	175	400	235	335	368	340	M12	190
FNP 125/2	FNDP 125/2	820	1400	520	420	209	400	200	400	368	340	M14	230
FNP 150/2	FNDP 150/2	820	1400	520	420	209	400	200	400	368	340	M14	230

СЕРИЯ FNDP

ПРОГРЕССИВНЫЕ И МОДУЛИРУЮЩИЕ ОТ 398 ДО 1705 кВт
Progressive and modulating from 398 up to 1705 kW



ПРОГРЕССИВНЫЕ И МОДУЛИРУЮЩИЕ PROGRESSIVE & MODULATING	kg/h		kW		⚡ 3F
	min	max	min	max	
FNDP 70/M	35	70	398	796	3F
FNDP 100/M	40	100	455	1137	
FNDP 125/M	60	125	682	1421	
FNDP 150/M	75	150	853	1705	

ТЕПЛОВЫЙ РАСХОД / РАЗМЕРЫ (мм) - FIRING RATES / OVERALL DIMENSIONS (mm)

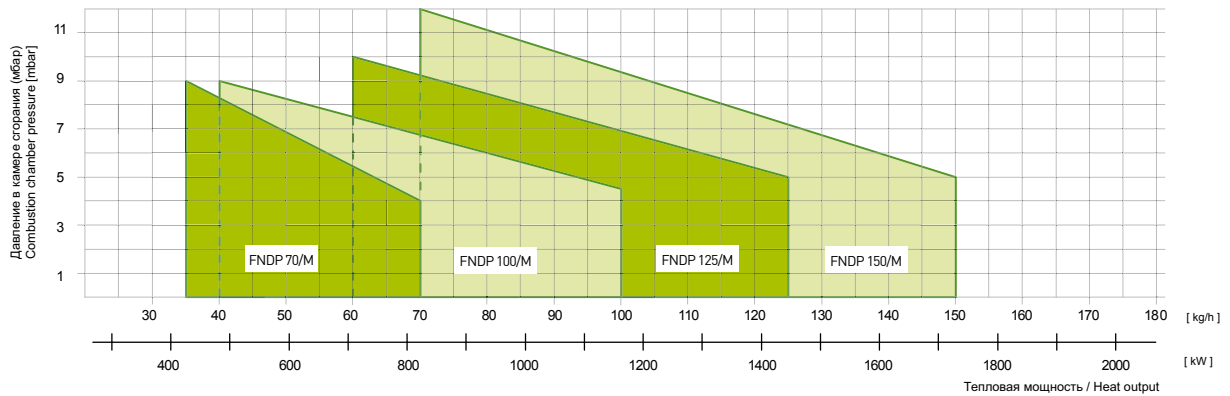
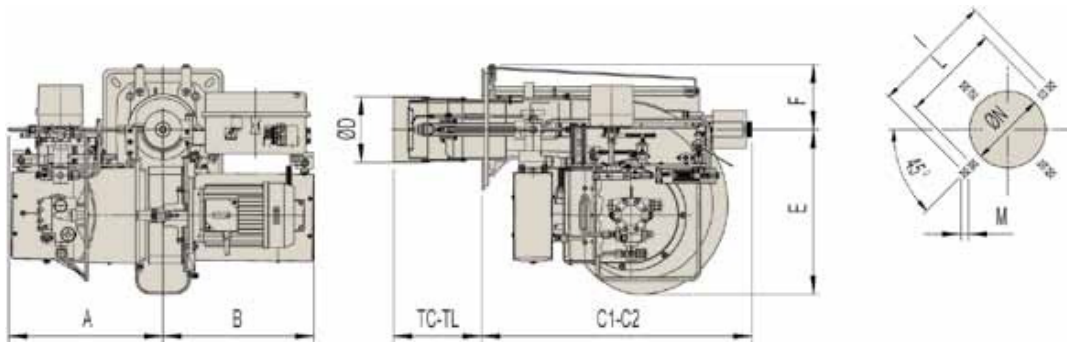

МОДЕЛЬ MODEL	A	B	C1	C2	D	E	F	TC	TL	I	L	M	N
FNDP 70/M	360	385	735	1175	165	355	171	250	350	368	340	M12	180
FNDP 100/M	410	400	720	1150	175	440	173	235	335	368	340	M12	190
FNDP 125/M	420	400	860	1440	209	520	213	200	400	368	340	M14	230
FNDP 150/M	420	400	860	1440	209	520	213	200	400	368	340	M14	230

C2= размер при отведенной назад горелке
C2= overall dimension with the burner out in position of maintenance



СЕРИЯ FNDP

ТРЕХСТУПЕНЧАТЫЕ ОТ 909 ДО 3979 кВт / 3 Stages from 909 up to 3979 kW



ТРЕХСТУПЕНЧАТЫЕ 3 STAGES	kg/h		kW		⚡
	min	max	min	max	
FNDP 190/3	80	206	909	2341	3F
FNDP 250/3	100	250	1137	2842	
FNDP 350/3	120	350	1364	3979	

ТЕПЛОВОЙ РАСХОД / РАЗМЕРЫ (мм) - FIRING RATES / OVERALL DIMENSIONS (mm)

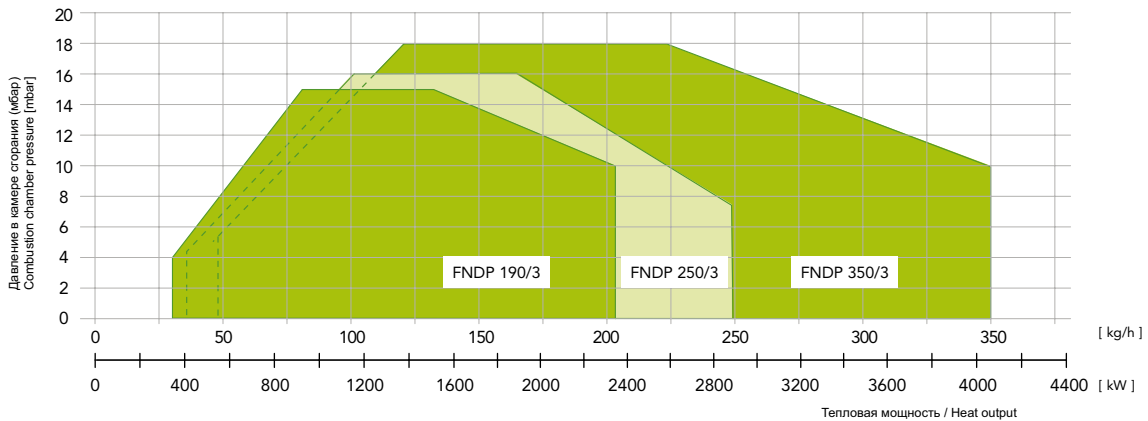
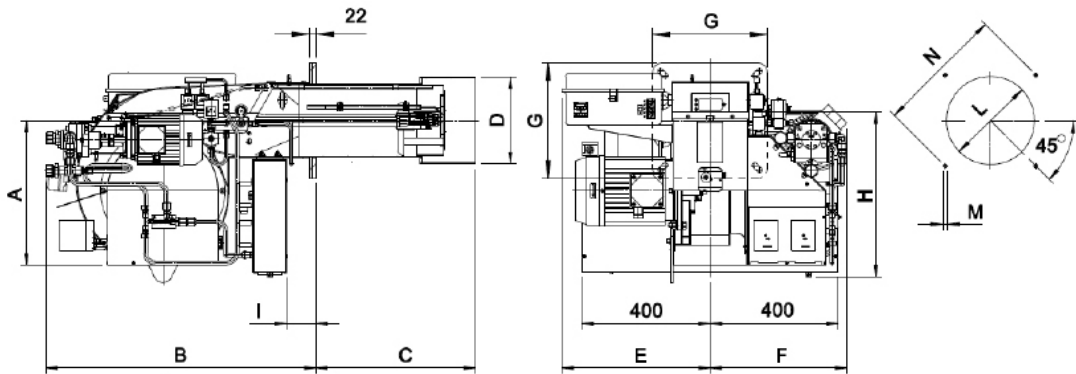

МОДЕЛЬ MODEL	* советовав/Suggested																
	A	B	C	D	E	F	G	H	I	L min	L*	L max	M	N min	N*	N max	R
FNDP 190/3	453	850	495	234	464	430	360	490	93	245	280	320	M14	396	424	438	R30
FNDP 250/3	453	850	500	271	464	430	360	490	93	280	280	320	M14	396	424	438	R30
FNDP 350/3	481	942	535	334	575	488	490	494	75	350	350	450	M14	552	552	580	R50



ПРОГРЕССИВНЫЕ И МОДУЛИРУЮЩИЕ
PROGRESSIVE & MODULATING

	kg/h		kW		3F
	min	max	min	max	
FNDP 190/M *	80	206	909	2341	
FNDP 250/M *	100	250	1137	2842	
FNDP 350/M *	120	350	1364	3979	

* Поставляются также версии с ИНВЕРТОРОМ и ЭЛЕКТРОННЫМ КУЛАЧКОМ
* Available also versions with INVERTER and ELECTRONIC BURNER CONTROL

ТЕПЛОВОЙ РАСХОД / РАЗМЕРЫ (мм) - FIRING RATES / OVERALL DIMENSIONS (mm)

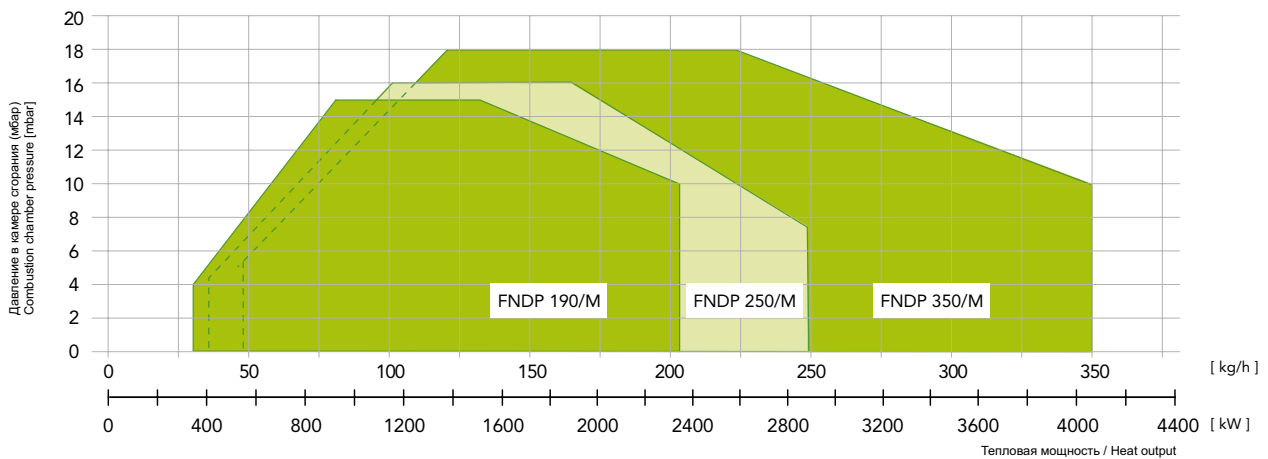
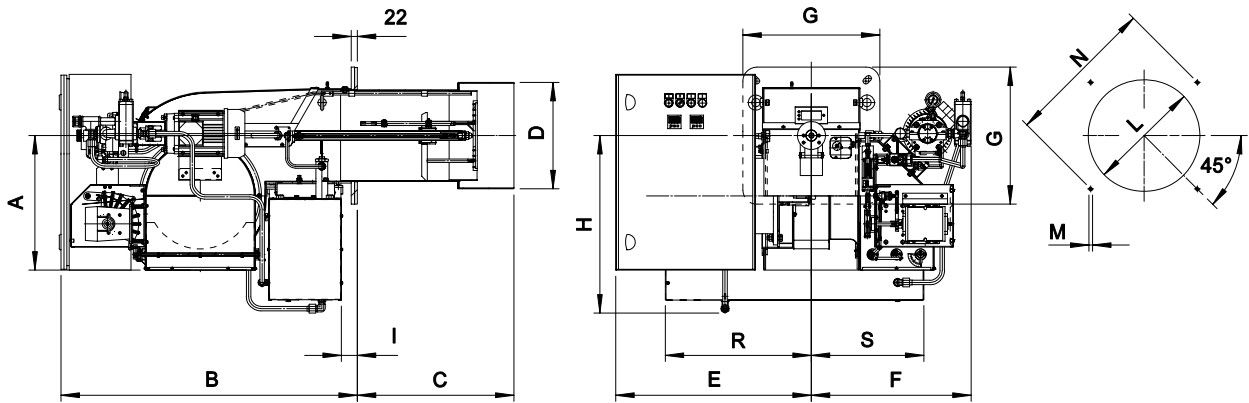

МОДЕЛЬ MODEL	* советовав/Suggested																	
	A	B	C	D	E	F	G	H	I	L min	L*	L max	M	N min	N*	N max	R	S
FNDP 190/M	453	920	495	234	545	536	360	490	93	245	280	320	M14	396	424	438	400	400
FNDP 250/M	453	920	500	271	545	536	360	490	93	280	280	320	M14	396	424	438	400	400
FNDP 350/M	481	1025	535	334	600	565	490	495	75	350	350	450	M14	552	552	580	400	400



СЕРИЯ FNDP

ПРОГРЕССИВНЫЕ И МОДУЛИРУЮЩИЕ ОТ 1819 ДО 6252 кВт
Progressive and modulating from 1819 up to 6252 kW



ПРОГРЕССИВНЫЕ И МОДУЛИРУЮЩИЕ PROGRESSIVE & MODULATING	kg/h		kW		3F
	min	max	min	max	
FNDP 450/M *	160	450	1819	5116	
FNDP 550/M *	200	550	2274	6252	

* Поставляются также версии с ИНВЕРТОРОМ и ЭЛЕКТРОННЫМ КУЛАЧКОМ
* Available also versions with INVERTER and ELECTRONIC BURNER CONTROL

ТЕПЛОВОЙ РАСХОД / РАЗМЕРЫ (мм) - FIRING RATES / OVERALL DIMENSIONS (mm)

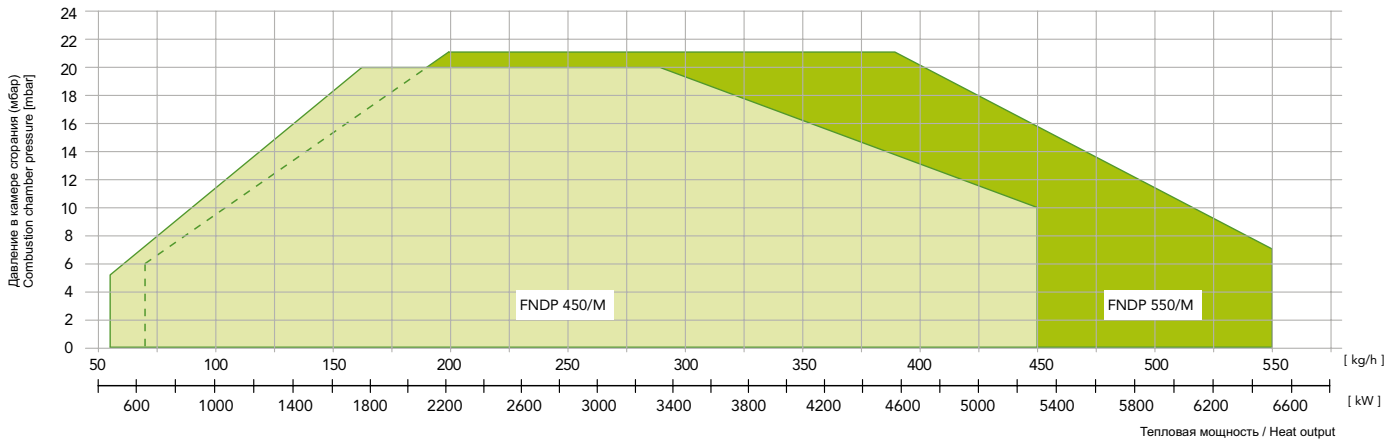
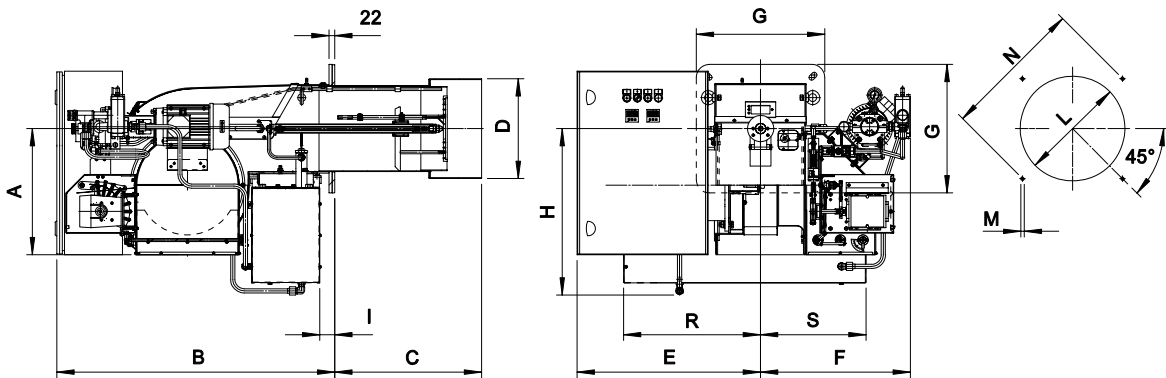

МОДЕЛЬ MODEL	* советовав/Suggested																	
	A	B	C	D	E	F	G	H	I	L min	L*	L max	M	N min	N*	N max	R	S
FNDP 450/M	481	1100	560	380	700	571	490	635	57	390	390	450	M14	552	552	580	520	400
FNDP 550/M	481	1100	560	380	700	571	490	635	57	390	410	450	M14	552	552	580	520	400



ПРОГРЕССИВНЫЕ И МОДУЛИРУЮЩИЕ PROGRESSIVE & MODULATING	kg/h		kW		⚡
	min	max	min	max	
FNDP 650/M *	300	650	3488	7558	3F
FNDP 750/M *	340	750	4000	8721	
FNDP 1000/M *	340	1000	4000	11628	
FNDP 1150/M *	367	1173	4186	13372	
FNDP 1300/M *	367	1326	4186	15116	
FNDP 1500/M *	500	1500	5815	17445	

* Поставляются также версии с ИНВЕРТОРОМ и ЭЛЕКТРОННЫМ КУЛАЧКОМ
* Available also versions with INVERTER and ELECTRONIC BURNER CONTROL

ТЕПЛОВЫЙ РАСХОД / РАЗМЕРЫ (мм) - FIRING RATES / OVERALL DIMENSIONS (mm)

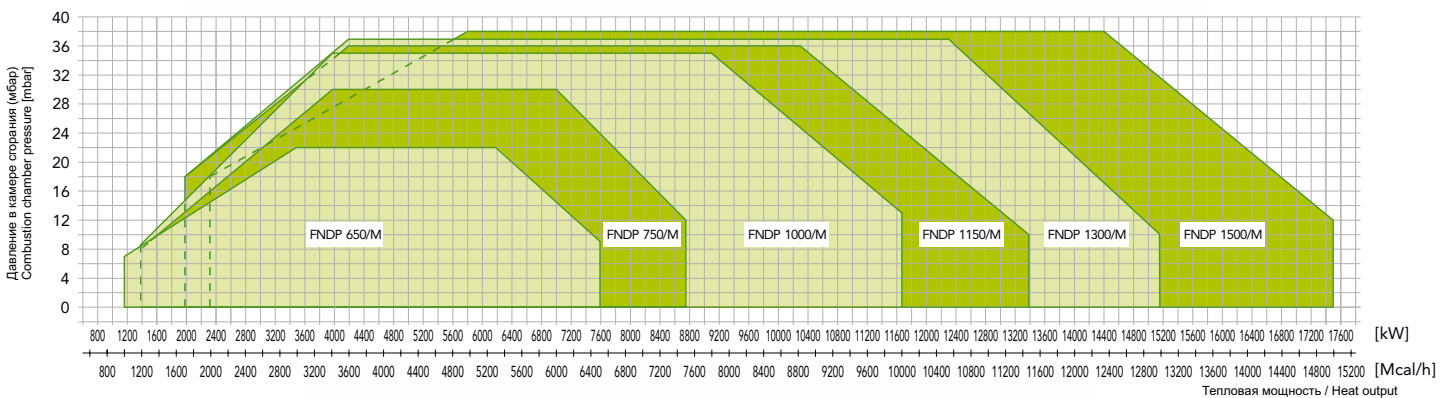

Please contact our Technical & Sales Offices for detailed technical data.

ГОРЕЛКИ ДЛЯ ГАЗА
GAS BURNERS



3





ОДНОСТУПЕНЧАТЫЕ 1 STAGE	kcal/h		kW		
	min	max	min	max	
GAS X 0	10.000	29.500	11,6	34,2	1F
GAS X 1	20.000	50.000	23,2	58	
GAS X 2	35.000	80.000	40,6	93	
GAS X 3 *	60.000	150.000	70	174	
GAS X 4 *	100.000	200.000	116	232	
GAS X 5	130.000	300.000	151	349	

* Имеются также в версии Low Nox

* Available also in Low NOx version

ТЕПЛОВЫЙ РАСХОД / РАЗМЕРЫ (мм) - FIRING RATES / OVERALL DIMENSIONS (mm)

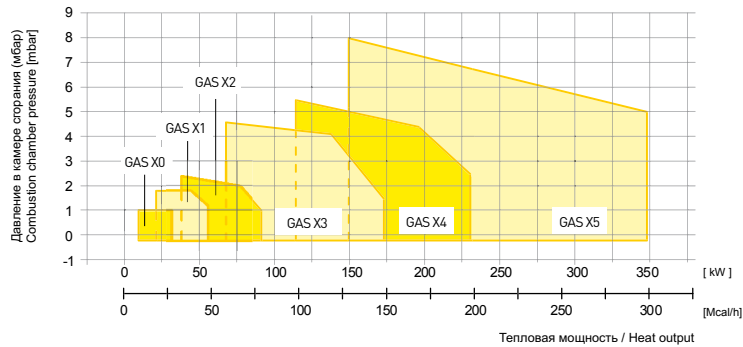
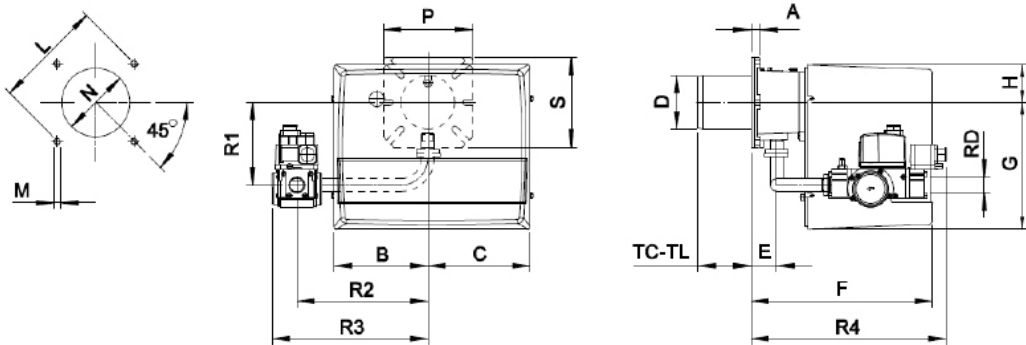

МОДЕЛЬ MODEL	* советоваи/Suggested																							
	A	B	C	D	E	F	G	H	L _{min}	L*	L _{max}	M	N _{min}	N*	N _{max}	P	S	TC	TL	R1	R2	R3	R4	RD
GAS X0 CE - D1/2"-S	15	140	140	90	43	265	169	72	130	150	170	M8	100	110	130	150	150	90	150	132	200	254	240	1/2"
GAS X1 CE - D1/2"-S	15	162	175	90	43	305	210	65	130	150	170	M8	100	110	130	150	150	90	150	132	200	254	240	1/2"
GAS X2 CE - D3/4"-S	15	162	175	90	43	305	210	65	130	150	170	M8	100	110	130	150	150	90	150	138	220	262	328	3/4"
GAS X3 CE - D1"-S	16	185	195	108	54	340	248	70	150	170	170	M8	120	130	140	200	160	130	250	168	280	337	361	1"
GAS X4 CE - D1"-S	20	185	195	125	78	368	248	70	170	205	226	M10	130	140	160	200	200	160	280	173	280	337	385	1"
GAS X5 CE - D1"-S	18	207	213	138	98	462	310	90	205	205	226	M10	150	150	180	200	200	250	335	160	305	362	403	1"
GAS X5 CE - CTD1"-S	18	207	213	138	98	462	310	90	205	205	226	M10	150	150	180	200	200	250	335	160	305	480	403	1"
GAS X5 CE - D1"1/4-S	18	207	213	138	98	462	310	90	205	205	226	M10	150	150	180	200	200	250	335	160	305	362	450	1"1/4
GAS X5 CE - CTD1"1/4-S	18	207	213	138	98	462	310	90	205	205	226	M10	150	150	180	200	200	250	335	160	305	480	450	1"1/4





СЕРИЯ X

ДВУХСТУПЕНЧАТЫЕ – ПРОГРЕССИВНЫЕ И МОДУЛИРУЮЩИЕ ОТ 23 ДО 349 кВт
2 stages - Progressive and modulating 23 up to 349 kW



ДВУХСТУПЕНЧАТЫЕ 2 STAGES	ПРОГРЕССИВНЫЕ И МОДУЛИРУЮЩИЕ PROGRESSIVE & MODULATING	kcal/h		kW		1F
		min	max	min	max	
GAS X 1/2		20.000	50.000	23,2	58	
GAS X 2/2	GAS X 2/M	35.000	80.000	40,6	93	
GAS X 3/2 *	GAS X 3/M *	60.000	150.000	70	174	
GAS X 4/2 *	GAS X 4/M *	100.000	200.000	116	232	
GAS X 5/2 *	GAS X 5/M *	130.000	300.000	151	349	

* Имеются также в версии Low Nox
* Available also in Low NOx version

ТЕПЛОВЫЙ РАСХОД / РАЗМЕРЫ (мм) - FIRING RATES / OVERALL DIMENSIONS (mm)

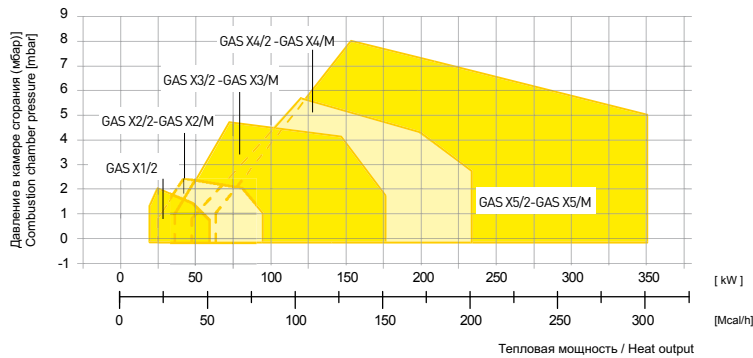
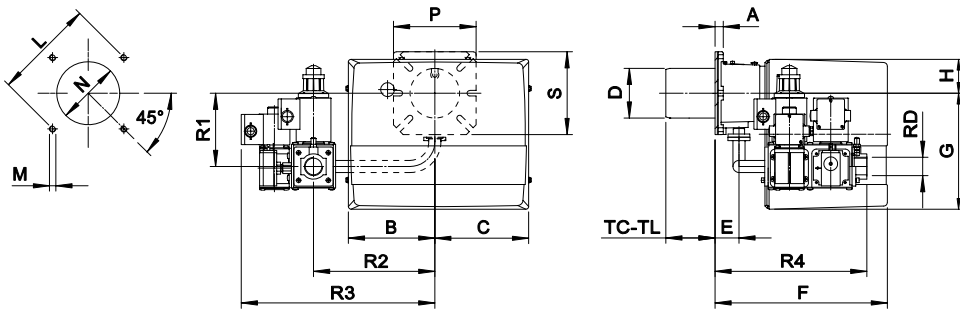

МОДЕЛЬ MODEL	* советовав/Suggested																							
	A	B	C	D	E	F	G	H	L	L*	L	M	N	N*	N	P	S	TC	TL	R1	R2	R3	R4	RD
GAS X 1/2 CE - D1/2" S	15	162	175	90	45	313	210	65	130	150	170	M8	100	110	130	150	150	90	150	132	200	275	258	1/2"
GAS X 2/2 CE - D3/4" FS25	15	162	175	90	45	313	210	65	130	150	170	M8	100	110	130	150	150	90	150	138	220	351	275	1"
GAS X 3/2 CE - D1" S	16	185	195	108	52	340	248	70	150	170	170	M8	120	130	140	200	160	130	250	168	280	337	361	1"
GAS X 4/2 CE - D1" S	20	185	195	125	78	368	248	70	170	205	226	M10	130	140	160	200	200	160	280	173	280	337	385	1"
GAS X 5/2 CE - D1" S	18	207	213	138	98	462	310	90	205	205	226	M10	150	150	180	200	200	250	335	255	305	362	403	1"
GAS X 5/2 CE - CT D1" S	18	207	213	138	98	462	310	90	205	205	226	M10	150	150	180	200	200	250	335	255	305	480	403	1"
GAS X 5/2 CE - D1" 1/4 S	18	207	213	138	98	462	310	90	205	205	226	M10	150	150	180	200	200	250	335	255	305	362	450	1" 1/4
GAS X 5/2 CE - CT D1" 1/4 S	18	207	213	138	98	462	310	90	205	205	226	M10	150	150	180	200	200	250	335	255	305	480	450	1" 1/4
GAS X 2/M CE - D3/4" S	15	162	200	90	45	305	211	65	130	150	170	M8	100	110	130	150	150	90	150	178	220	262	346	3/4"
GAS X 3/M CE - D1" S	16	185	224	108	54	340	248	70	150	170	170	M8	120	130	140	200	160	130	250	228	280	338	360	1"
GAS X 4/M CE - D1" S	20	185	224	125	78	368	248	70	170	205	226	M10	130	140	160	200	200	160	280	233	280	338	385	1"
GAS X 5/M CE - D1" S	18	207	213	138	98	462	310	165	205	205	226	M10	150	150	180	200	200	250	335	160	305	395	508	1"
GAS X5/M CE - D1" 1/4 S	18	207	213	138	98	462	310	165	205	205	226	M10	150	150	180	200	200	250	335	160	305	395	508	1" 1/4



ОДНОСТУПЕНЧАТЫЕ для хлебопекарных печей 1 STAGE for bakery ovens	kcal/h		kW		1F
	min	max	min	max	
GAS X 1 F	20.000	50.000	23,2	58	
GAS X 2 F	35.000	80.000	40,6	93	
GAS X 3 F	60.000	150.000	70	174	
GAS X 4 F	100.000	200.000	116	232	
GAS X 5 F	130.000	300.000	151	349	

ТЕПЛОВОЙ РАСХОД / РАЗМЕРЫ (мм) - FIRING RATES / OVERALL DIMENSIONS (mm)

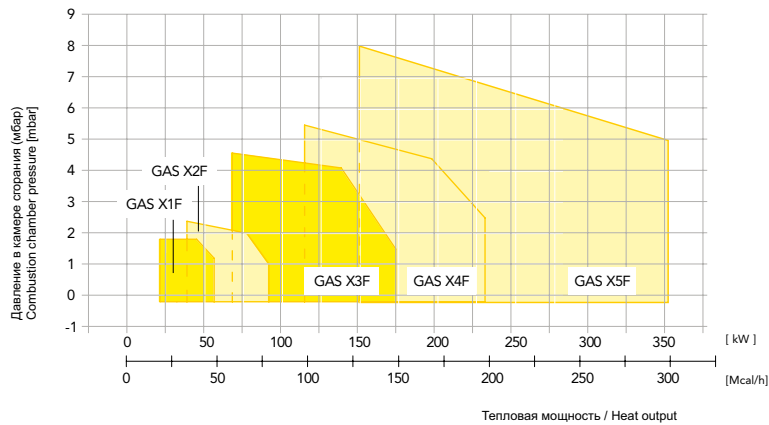
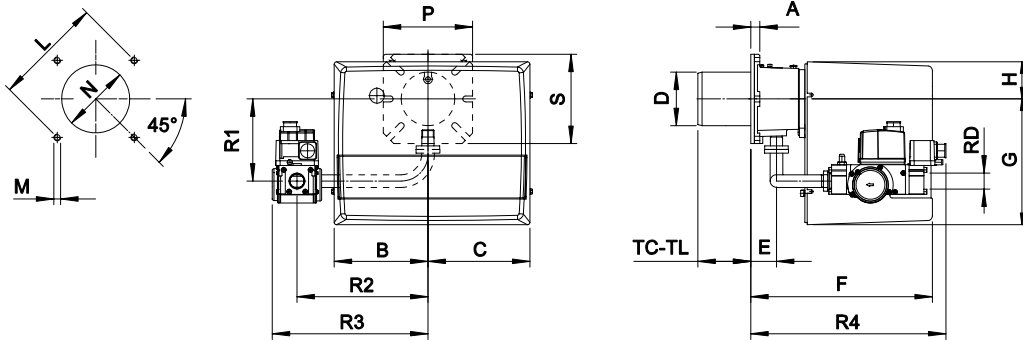

МОДЕЛЬ MODEL	* советоваи/Suggested																							
	A	B	C	D	E	F	G	H	L _{min}	L*	L _{max}	M	N _{min}	N*	N _{max}	P	S	TC	TL	R1	R2	R3	R4	RD
GAS X 1 CE F - D1/2" S	15	162	175	90	43	305	210	65	130	150	170	M8	100	110	130	150	150	90	150	132	200	254	240	1/2"
GAS X 2 CE F - D3/4" S	15	162	175	90	43	305	210	65	130	150	170	M8	100	110	130	150	150	90	150	138	220	262	328	3/4"
GAS X 3 CE F - D1" S	16	185	195	108	54	340	248	70	150	170	170	M8	120	130	140	200	160	130	250	168	280	337	361	1"
GAS X 4 CE F - D1" S	20	185	195	125	78	368	248	70	170	205	226	M10	130	140	160	200	200	160	280	173	280	337	385	1"
GAS X5 CE F - D1" S	18	207	213	138	98	462	310	90	205	205	226	M10	150	150	180	200	200	250	335	160	305	362	403	1"



СЕРИЯ C & THLS

ОДНОСТУПЕНЧАТЫЕ ОТ 11 ДО 70 кВт / 1 stage from 11 up to 70 kW



ОДНОСТУПЕНЧАТЫЕ для кухни 1 STAGE for kitchens	kcal/h		kW		
	min	max	min	max	
GAS 1/C	10.000	40.000	11,6	47	1F
GAS 2/C	15.000	60.000	17,5	70	

СЕРИЯ "X0 THLS" для кухни "X0 THLS" SERIE for units	kcal/h		kW		
	min	max	min	max	
GAS X0 THLS	10.000	29.500	11,6	34,2	1F

ТЕПЛОВОЙ РАСХОД / РАЗМЕРЫ (мм) - FIRING RATES / OVERALL DIMENSIONS (mm)

GAS 1/C - GAS 2/C

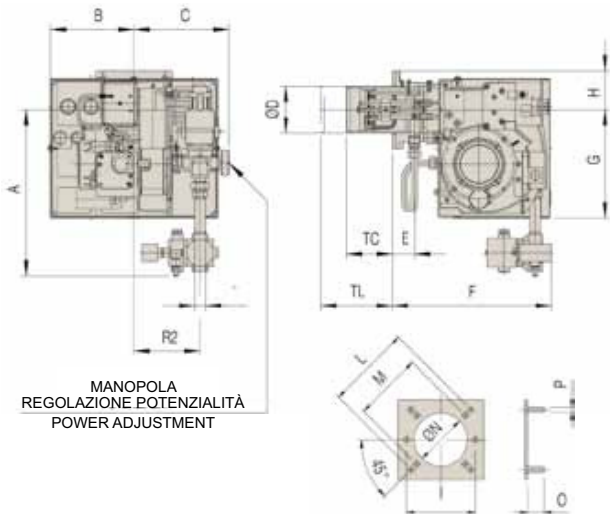

GAS X0 THLS

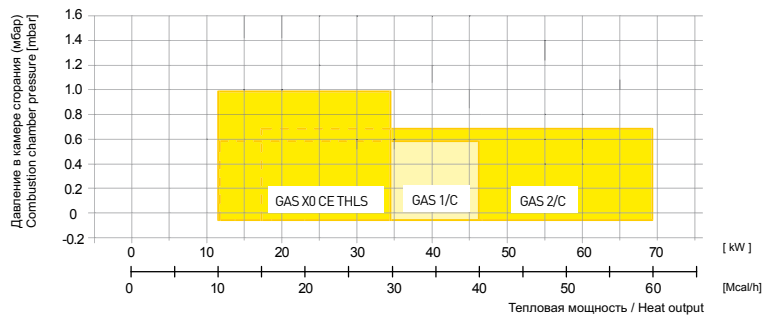
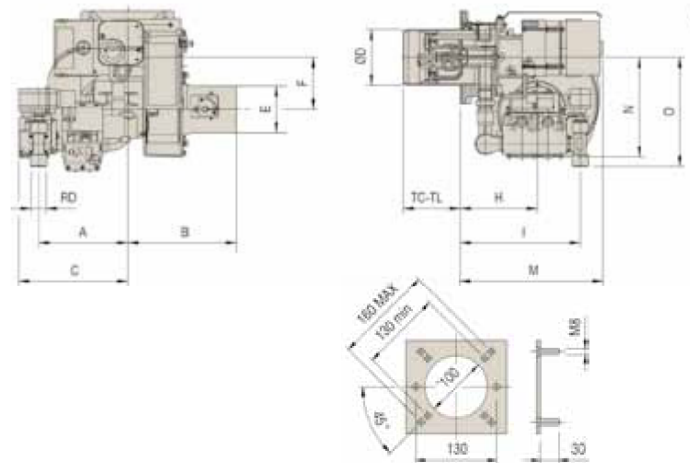

МОДЕЛЬ MODEL	A	B	C	D	E	F	G	H	I	L	M	N	O	P	TC	TL	R2	
GAS 1/C	321	166	184	90	43	310	210	75	130	160	130	100	30	M8	85	145	128	1/2"
GAS 2/C	321	166	184	90	43	310	210	75	130	160	130	100	30	M8	85	145	128	1/2"

МОДЕЛЬ MODEL	A	B	C	D	E	F	H	I	TC	TL	M	N	O	RD
GAS X0 CE THLS - D1/2"	144	169	176	90	80	84	125	193	92	152	230	161	176	1/2"



ОДНОСТУПЕНЧАТЫЕ 1 STAGE	kcal/h		kW		
	min	max	min	max	
GAS XP 60	200.000	450.000	232	522	3F

ТЕПЛОВОЙ РАСХОД / РАЗМЕРЫ (мм) - FIRING RATES / OVERALL DIMENSIONS (mm)

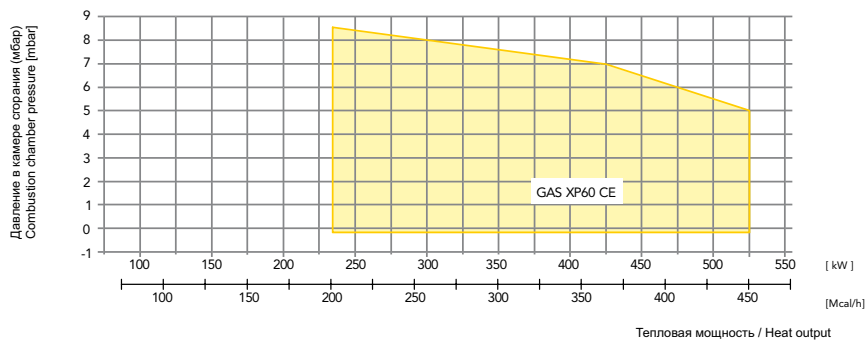
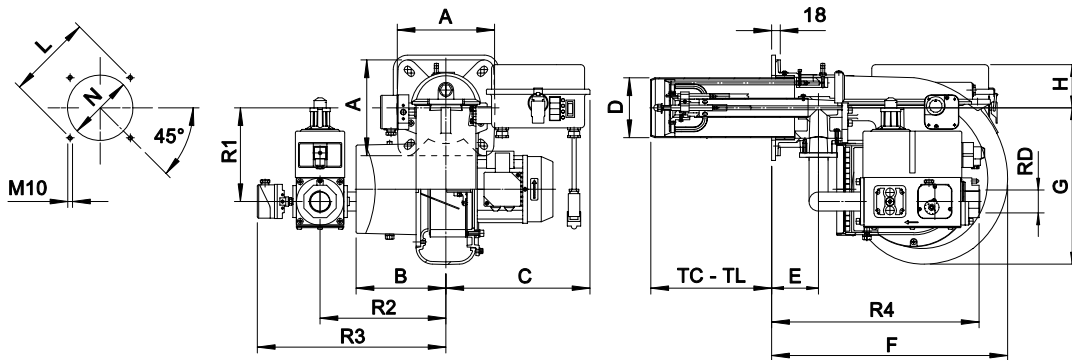

МОДЕЛЬ MODEL	A	B	C	D	E	F	G	H	L min*	L max	N min*	N max	TC	TL	R1	R2	R3	R4	RD	* советовав/Suggested
																				1F
GASP XP 60 CE - D1" - S	200	188	301	150	98	493	327	90	205	226	160	180	250	335	202	280	337	445	1"	1F
GASP XP 60 CE - D1" 1/4 - S	200	188	301	150	98	493	327	90	205	226	160	180	250	335	202	280	337	445	1" 1/4	1F
GAS XP 60 CE - D1" 1/2 - FS40	200	188	301	150	98	493	327	90	205	226	160	180	250	335	202	280	420	456	1" 1/2	3F
GAS XP 60 CE - D1" 1/2 - FS50	200	188	301	150	98	493	327	90	205	226	160	180	250	335	202	280	420	456	1" 1/2	3F



СЕРИЯ XP

ДВУХСТУПЕНЧАТЫЕ – ПРОГРЕССИВНЫЕ И МОДУЛИРУЮЩИЕ ОТ 232 ДО 522 кВт
2 stages - Progressive and modulating from 232 up to 522 kW



ДВУХСТУПЕНЧАТЫЕ 2 STAGES	ПРОГРЕССИВНЫЕ И МОДУЛИРУЮЩИЕ PROGRESSIVE & MODULATING	kcal/h		kW		3F
		min	max	min	max	
GAS XP 60/2 *	GAS XP 60/M *	200.000	450.000	232	522	3F

* Имеются также в версии Low Nox

* Available also in Low NOx version

ТЕПЛОВОЙ РАСХОД / РАЗМЕРЫ (мм) - FIRING RATES / OVERALL DIMENSIONS (mm)

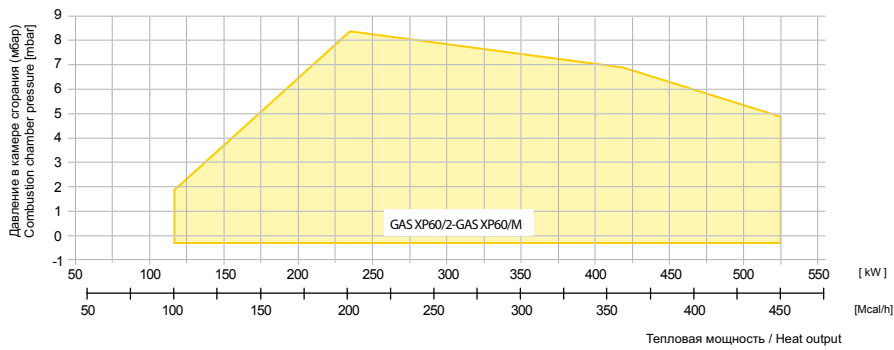
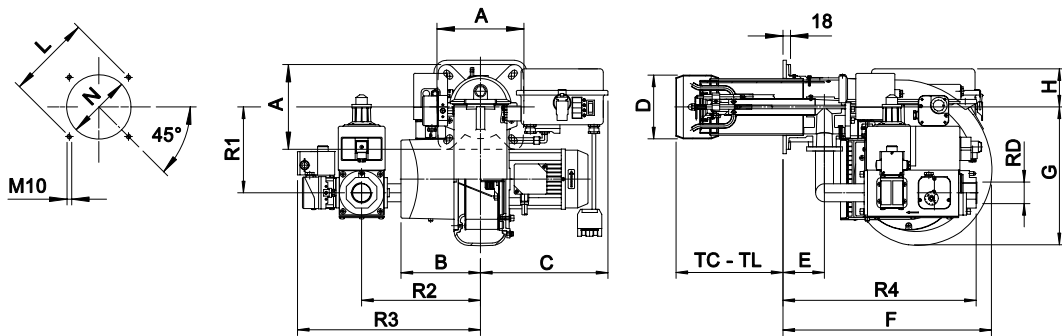

МОДЕЛЬ MODEL	A	B	C	D	E	F	G	H	L min*	L max	N min*	N max	TC	TL	R1	R2	R3	R4	RD	* советоваи/Suggested
GASP XP 60/2 CE - D1" - S	200	188	301	150	98	493	327	90	205	226	160	180	250	335	202	280	337	445	1"	
GASP XP 60/2 CE - D1" 1/4 - S	200	188	301	150	98	493	327	90	205	226	160	180	250	335	202	280	337	445	1" 1/4	
GAS XP 60/2 CE - D1" 1/2 - FS40	200	188	301	150	98	493	327	90	205	226	160	180	250	335	202	280	432	456	1" 1/2	
GAS XP 60/2 CE - D1" 1/2 - FS50	200	188	301	150	98	493	327	90	205	226	160	180	250	335	202	280	432	456	1" 1/2	
GASP XP 60/M CE - D1" - S	200	331	301	150	98	493	327	90	205	226	160	180	250	335	202	403	460	445	1"	
GASP XP 60/M CE - D1" 1/4 - S	200	331	301	150	98	493	327	90	205	226	160	180	250	335	202	403	460	445	1" 1/4	
GAS XP 60/M CE - D1" 1/2 - FS40	200	331	301	150	98	493	327	90	205	226	160	180	250	335	202	411	550	468	1" 1/2	
GAS XP 60/M CE - D1" 1/2 - FS50	200	331	301	150	98	493	327	90	205	226	160	180	250	335	202	411	550	468	1" 1/2	

СЕРИЯ P и P/M

ДВУХСТУПЕНЧАТЫЕ – ПРОГРЕССИВНЫЕ И МОДУЛИРУЮЩИЕ ОТ 406 ДО 1744 кВт
2 stages - Progressive and modulating from 406 up to 1744 kW



ДВУХСТУПЕНЧАТЫЕ 2 STAGES	ПРОГРЕССИВНЫЕ И МОДУЛИРУЮЩИЕ PROGRESSIVE & MODULATING	kcal/h		kW		3F
		min	max	min	max	
GAS P 70/2	GAS P 70/M	350.000	650.000	406	754	3F
GAS P 100/2*	GAS P 100/M*	500.000	1.000.000	580	1160	
GAS P 150/2*	GAS P 150/M*	700.000	1.500.000	814	1744	

* Имеются также в версии Low Nox
* Available also in Low NOx version

ТЕПЛОВЫЙ РАСХОД / РАЗМЕРЫ (мм) - FIRING RATES / OVERALL DIMENSIONS (mm)

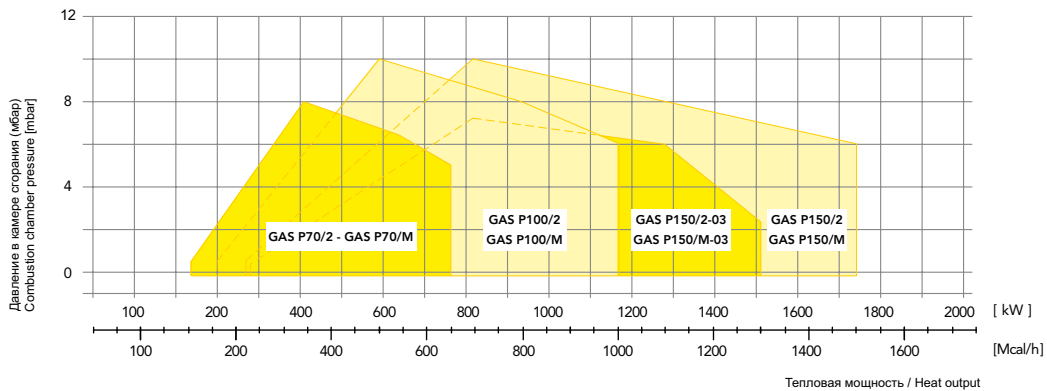
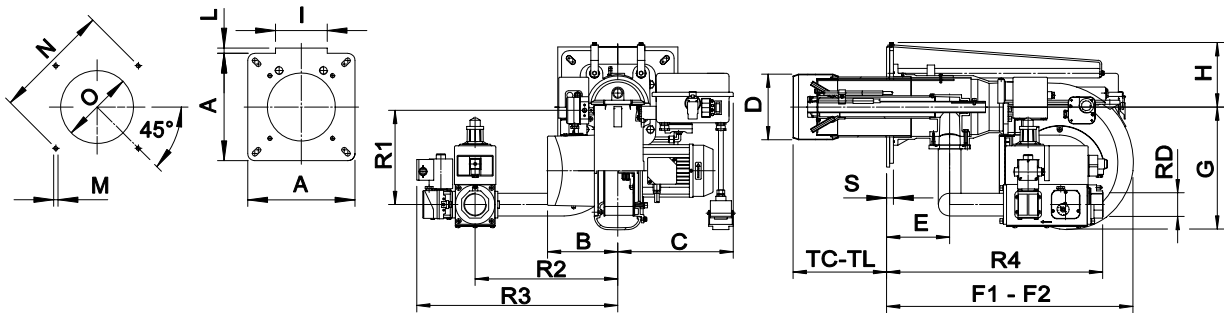

* советовав/Suggested

МОДЕЛЬ MODEL	A	B	C	D	E	F1	F2	G	H	I	L	M	N min	N max	O min*	O max	TC	TL	S	R1	R2	R3	R4	RD	F2= размер при отведенной назад горелке F2= overall dimension with the burner out in position of maintenance	
																									F1	F2
GAS P 70/2 CE - D1" 1/2-FS50	300	188	308	175	168	660	1100	327	171	144	10	M12	310	368	185	250	250	385	18	260	380	532	576	1" 1/2		
GAS P 70/2 CE - D2"-FS50	300	188	308	175	168	660	1100	327	171	144	10	M12	310	368	185	250	250	385	18	260	380	536	576	2"		
GAS P 100/2 CE - D1" 1/2-FS50	300	238	372	185	184	660	1160	438	173	0	0	M12	340	368	195	250	250	385	18	260	380	532	591	1" 1/2		
GAS P 100/2 CE - D2"-FS50	300	238	372	185	184	660	1160	438	173	0	0	M12	340	368	195	250	250	385	18	260	380	536	591	2"		
GAS P 100/2 CE - DN65-FS65	300	238	372	185	184	660	1160	438	173	0	0	M12	340	368	195	250	250	385	18	260	380	540	630	DN65		
GAS P 150/2 CE - D2"-FS50	320	238	372	209	193	800	1380	438	213	183	40	M14	340	368	220	250	280	400	23	284	380	552	600	2"		
GAS P 150/2 CE - DN65-FS65	320	238	372	209	193	800	1380	438	213	183	40	M14	340	368	220	250	280	400	23	228	340	495	585	DN65		
GAS P 150/2 CE - DN80-FS80	320	238	372	209	193	800	1380	438	213	183	40	M14	340	368	220	250	280	400	23	228	420	590	605	DN80		
GAS P 70/M CE - D1" 1/2-FS50	300	331	362	175	168	660	1100	327	171	144	10	M12	310	368	185	250	250	385	18	260	415	553	538	1" 1/2		
GAS P 70/M CE - D2"-FS50	300	331	362	175	168	660	1100	327	171	144	10	M12	310	368	185	250	250	385	18	260	415	553	538	2"		
GAS P 100/M CE - D1" 1/2-FS50	300	376	372	185	184	660	1160	438	173	0	0	M12	340	368	195	250	250	385	18	260	460	600	554	1" 1/2		
GAS P 100/M CE - D2"-FS50	300	376	372	185	184	660	1160	438	173	0	0	M12	340	368	195	250	250	385	18	260	500	592	580	DN65		
GAS P 150/M CE - D2"-FS50	320	376	372	209	193	800	1380	438	213	183	40	M14	340	368	220	250	280	400	23	228	510	673	552	2"		
GAS P 150/M CE - DN65-FS65	320	376	372	209	193	800	1380	438	213	183	40	M14	340	368	220	250	280	400	23	228	510	665	590	DN65		
GAS P 150/M CE - DN80-FS80	320	376	372	209	193	800	1380	438	213	183	40	M14	340	368	220	250	280	400	23	228	550	720	630	DN80		



СЕРИЯ P и P/M

ДВУХСТУПЕНЧАТЫЕ – ПРОГРЕССИВНЫЕ И МОДУЛИРУЮЩИЕ ОТ 1044 ДО 3488 кВт
2 stages - Progressive and modulating from 1044 up to 3488 kW



ДВУХСТУПЕНЧАТЫЕ 2 STAGES	ПРОГРЕССИВНЫЕ И МОДУЛИРУЮЩИЕ PROGRESSIVE & MODULATING	kcal/h		kW		3Ф
		min	max	min	max	
GAS P 190/2*	GAS P 190/M* **	900.000	1.900.000	1044	2209	
GAS P 250/2*	GAS P 250/M* **	1.000.000	2.500.000	1160	2900	
GAS P 300/2*	GAS P 300/M* **	1.200.000	3.000.000	1390	3488	

* Имеются также в версии Low Nox
* Available also in Low NOx version
** Поставляются также версии с ИНВЕРТОРОМ и ЭЛЕКТРОННЫМ КУЛАЧКОМ
** Available also versions with INVERTER and ELECTRONIC BURNER CONTROL

ТЕПЛОВЫЙ РАСХОД / РАЗМЕРЫ (мм) - FIRING RATES / OVERALL DIMENSIONS (mm)

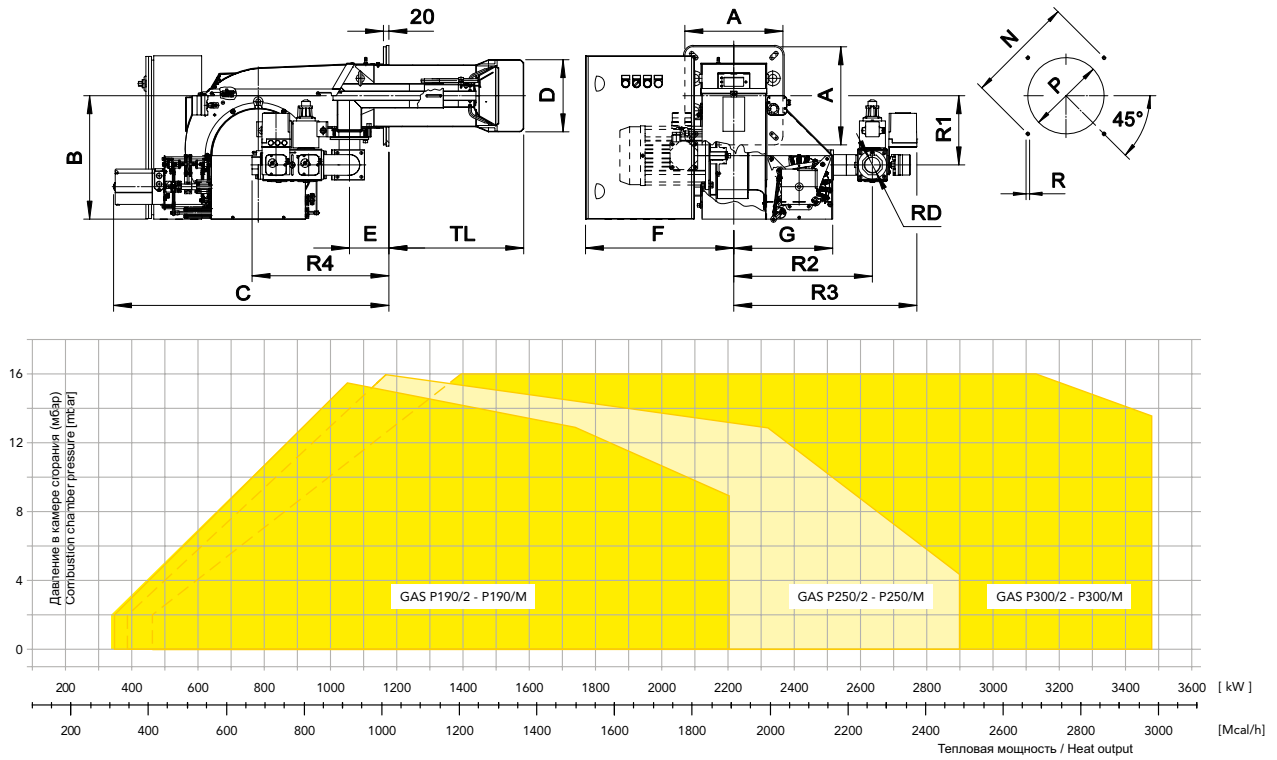

МОДЕЛЬ MODEL	* советовав/Suggested															
	A	B	C	D	E	F	G	TL	N min	N*	N max	P min*	P max	R	R1	R2
GAS P 190/2 CE	360	453	920	265	145	545	363	495	396	424	438	280	320	M14	275	570
GAS P 250/2 CE	360	453	920	270	145	545	363	495	396	424	438	280	320	M14	275	570
GAS P 300/2 CE	360	453	920	300	145	545	363	495	396	424	438	310	320	M14	275	570
GAS P 190/M CE	360	453	1010	265	145	545	363	495	396	424	438	280	320	M14	254	509
GAS P 250/M CE	360	453	1010	270	145	545	363	495	396	424	438	280	320	M14	254	480
GAS P 300/M CE	360	453	1010	300	145	545	363	495	396	424	438	310	320	M14	254	480

МОДЕЛЬ MODEL	* советовав/Suggested																							
	GAS P190/2 CE				GAS P250/2 CE				GAS P300/2 CE				GAS P190/M CE				GAS P250/M CE				GAS P300/M CE			
R3	734	724	736	745	734	724	736	745	734	724	736	745	672	634	647	654	672	634	647	654	672	634	647	654
R4	656	688	708	748	656	688	708	748	656	688	708	748	504	688	708	748	504	688	708	748	504	688	708	748
RD	2"	DN65	DN80	DN100	2"	DN65	DN80	DN100	2"	DN65	DN80	DN100	2"	DN65	DN80	DN100	2"	DN65	DN80	DN100	2"	DN65	DN80	DN100



ПРОГРЕССИВНЫЕ И МОДУЛИРУЮЩИЕ PROGRESSIVE & MODULATING	kcal/h		kW		3F
	min	max	min	max	
GAS P 350/M* **	1.200.000	3.500.000	1392	4060	3F
GAS P 450/M* **	1.600.000	4.500.000	1856	5220	
GAS P 550/M* **	2.000.000	5.500.000	2320	6380	
GAS P 650/M* **	3.000.000	6.500.000	3488	7558	

* Имеются также в версии Low Nox
* Available also in Low NOx version
** Поставляются также версии с ИНВЕРТОРОМ и ЭЛЕКТРОННЫМ КУЛАЧКОМ
** Available also versions with INVERTER and ELECTRONIC BURNER CONTROL

ТЕПЛОВЫЙ РАСХОД / РАЗМЕРЫ (ММ) - FIRING RATES / OVERALL DIMENSIONS (mm)

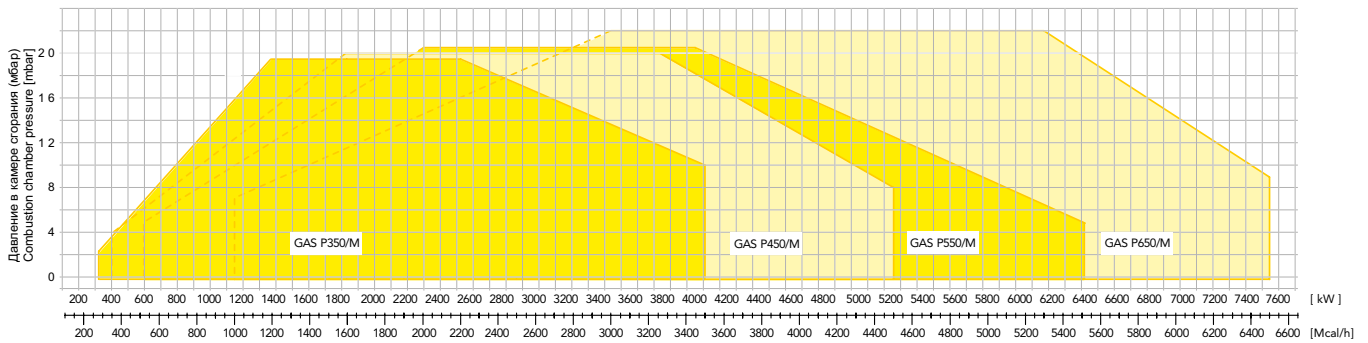
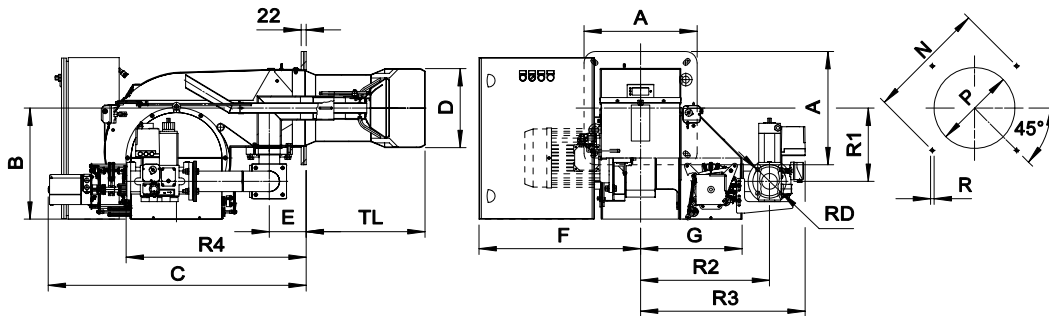

Тепловая мощность / Heat output

МОДЕЛЬ MODEL	* советовав/Suggested																			
	A	B	C	D	E	F	G	TL	N min	N*	N max	P min	P*	P max	R	R1	R2	R3	R4	RD
GAS P 350/M CE - D2" - FS50	490	481	1118	342	160	600	440	515	552	552	580	350	360	450	M14	317	535	660	570	2"
GAS P 350/M CE - DN65 - FS65	490	481	1118	342	160	600	440	515	552	552	580	350	360	450	M14	317	560	714	780	DN65
GAS P 350/M CE - DN80 - FS80	490	481	1118	342	160	600	440	515	552	552	580	350	360	450	M14	317	560	727	800	DN80
GAS P 350/M CE - DN100 - FS100	490	481	1118	342	160	600	440	515	552	552	580	350	360	450	M14	317	590	765	840	DN100
GAS P 450/M CE - D2" - FS50	490	481	1118	382	160	600	440	520	552	552	580	390	400	450	M14	317	535	660	570	2"
GAS P 450/M CE - DN65 - FS65	490	481	1118	382	160	600	440	520	552	552	580	390	400	450	M14	317	560	714	780	DN65
GAS P 450/M CE - DN80 - FS80	490	481	1118	382	160	600	440	520	552	552	580	390	400	450	M14	317	560	727	800	DN80
GAS P 450/M CE - DN100 - FS100	490	481	1118	382	160	600	440	520	552	552	580	390	400	450	M14	317	590	765	840	DN100
GAS P 550/M CE - D2" - FS50	490	481	1118	402	160	661	440	520	552	552	580	410	420	450	M14	317	535	660	570	2"
GAS P 550/M CE - DN65 - FS65	490	481	1118	402	160	661	440	520	552	552	580	410	420	450	M14	317	560	714	780	DN65
GAS P 550/M CE - DN80 - FS80	490	481	1118	402	160	661	440	520	552	552	580	410	420	450	M14	317	560	727	800	DN80
GAS P 550/M CE - DN100 - FS100	490	481	1118	402	160	661	440	520	552	552	580	410	420	450	M14	317	590	765	840	DN100
GAS P 650/M CE - DN65 - FS65	490	481	1118	420	160	700	440	490	552	552	580	430	440	450	M14	317	560	714	780	DN65
GAS P 650/M CE - DN80 - FS80	490	481	1118	420	160	700	440	490	552	552	580	430	440	450	M14	317	560	727	800	DN80
GAS P 650/M CE - DN100 - FS100	490	481	1118	420	160	700	440	490	552	552	580	430	440	450	M14	317	590	765	840	DN100



СЕРИЯ P и P/M

ПРОГРЕССИВНЫЕ И МОДУЛИРУЮЩИЕ ОТ 4000 ДО 17445 кВт
Progressive and modulating from 4000 up to 17445 kW



ПРОГРЕССИВНЫЕ И МОДУЛИРУЮЩИЕ PROGRESSIVE & MODULATING	kcal/h		kW		⚡
	min	max	min	max	
GAS P 750/M MEC *	3.400.000	7.500.000	4000	8721	3F
GAS P 1000/M MEC *	3.400.000	10.000.000	4000	11628	
GAS P 1150/M MEC *	3.600.000	11.500.000	4186	13372	
GAS P 1300/M MEC *	3.600.000	13.000.000	4186	15116	
GAS P 1500/M MEC *	5.000.000	15.000.000	5815	17445	

* Versions with MECHANICAL CAMME

ТЕПЛОВОЙ РАСХОД / РАЗМЕРЫ (мм) - FIRING RATES / OVERALL DIMENSIONS (mm)

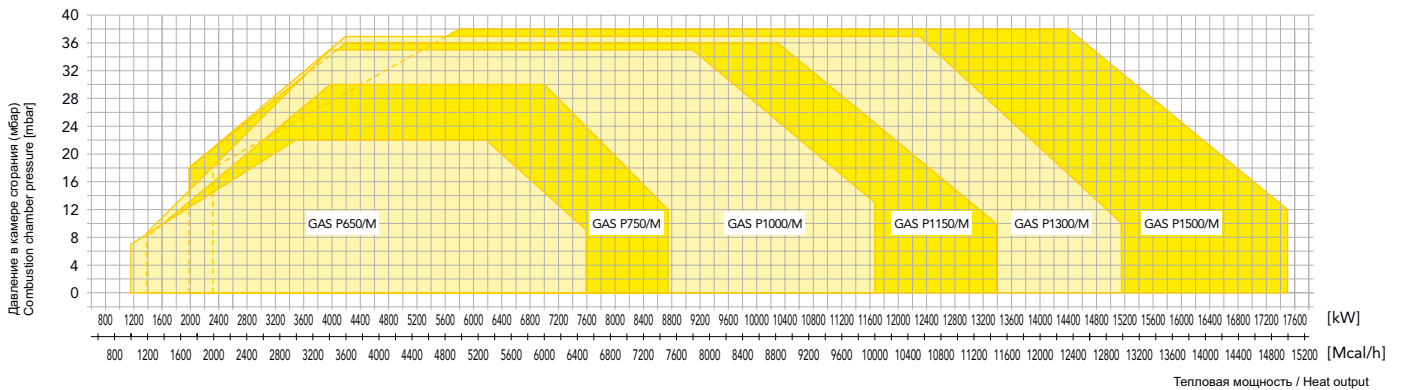

Please contact our Technical & Sales Offices for detailed technical data.

СЕРИЯ P/M

ПРОГРЕССИВНЫЕ И МОДУЛИРУЮЩИЕ ОТ 4000 ДО 17445 кВт
Progressive and modulating from 4000 up to 17445 kW



ПРОГРЕССИВНЫЕ И МОДУЛИРУЮЩИЕ PROGRESSIVE & MODULATING	kcal/h		kW		3F
	min	max	min	max	
GAS P 750/M EL *	3.400.000	7.500.000	4000	8721	
GAS P 1000/M EL *	3.400.000	10.000.000	4000	11628	
GAS P 1150/M EL *	3.600.000	11.500.000	4186	13372	
GAS P 1300/M EL *	3.600.000	13.000.000	4186	15116	
GAS P 1500/M EL *	5.000.000	15.000.000	5815	17445	

* Versions with ELECTRONIC CAMME
Available also with INVERTER

ТЕПЛОВЫЙ РАСХОД / РАЗМЕРЫ (мм) - FIRING RATES / OVERALL DIMENSIONS (mm)

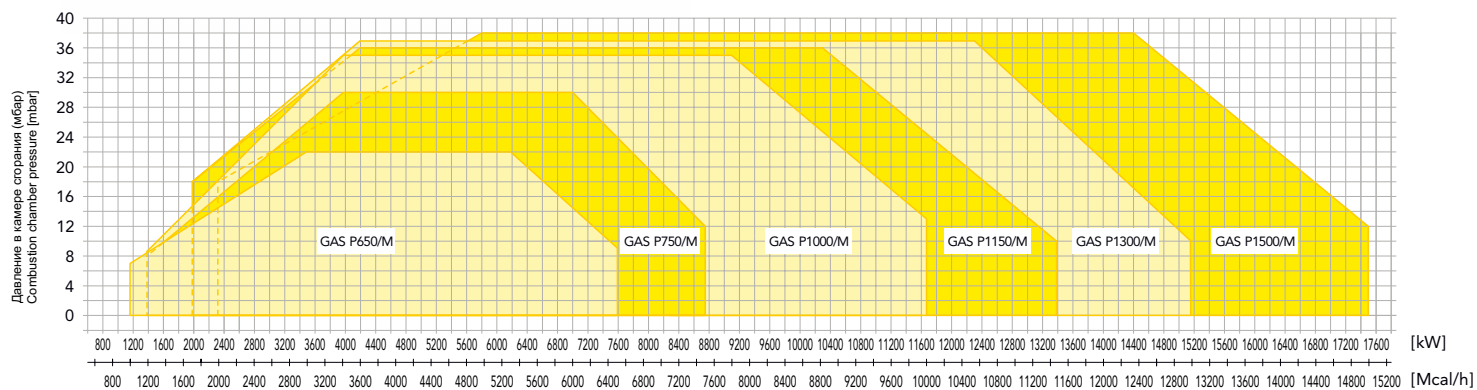

Тепловая мощность / Heat output



Please contact our Technical & Sales Offices for detailed technical data.

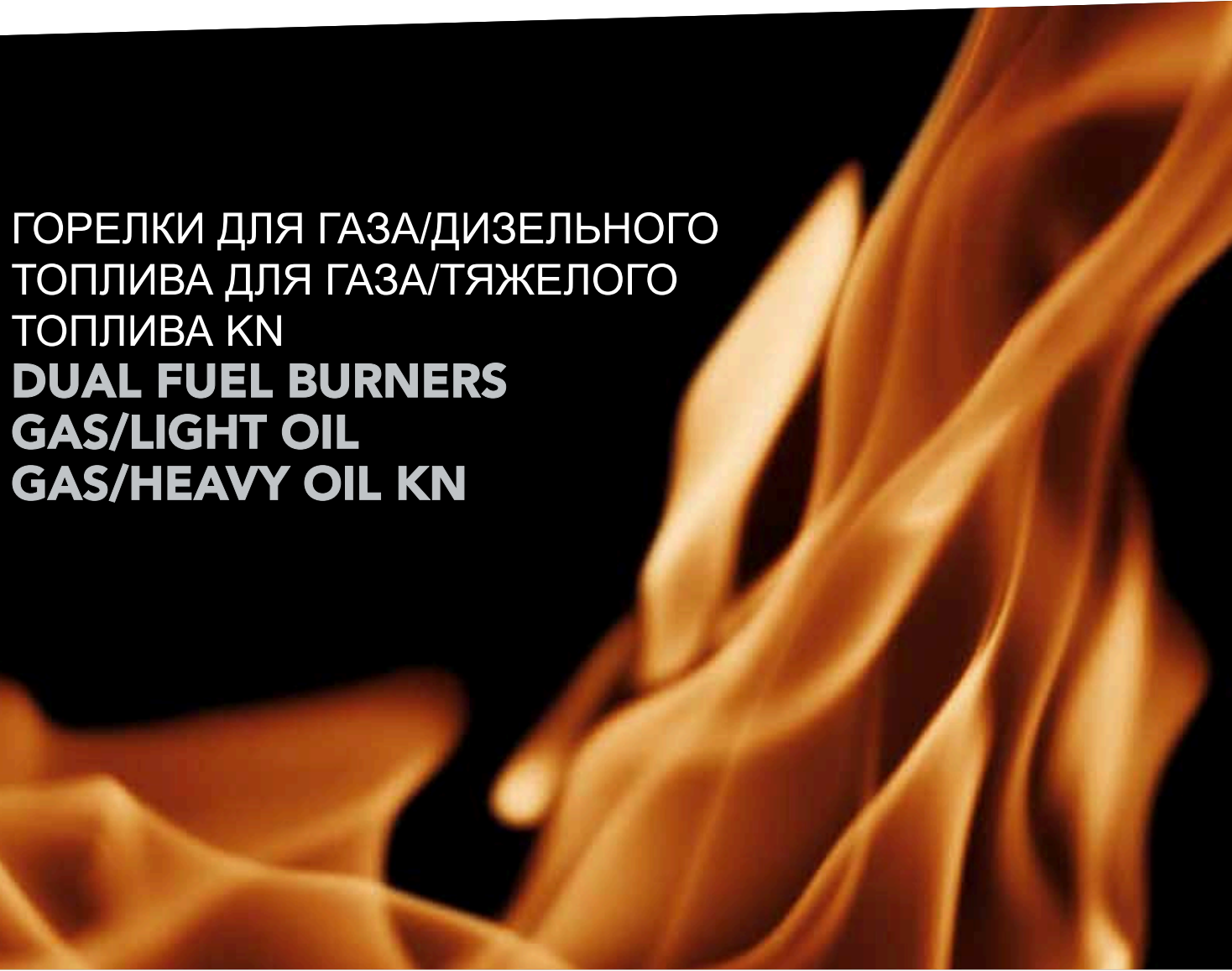

ГОРЕЛКИ ДЛЯ ГАЗА/ДИЗЕЛЬНОГО
ТОПЛИВА ДЛЯ ГАЗА/ТЯЖЕЛОГО
ТОПЛИВА KN

DUAL FUEL BURNERS
GAS/LIGHT OIL
GAS/HEAVY OIL KN



4

СЕРИЯ GMX

ОДНОСТУПЕНЧАТЫЕ ОТ 22 ДО 232 кВт / 1 stage from 22 up to 232 kW



газ/дизельное топливо - Gas/Light Oil



ОДНОСТУПЕНЧАТЫЕ 1 STAGE	kcal/h		kW		1F
	min	max	min	max	
GM X 0	19.500	29.500	22,6	34,2	
GM X 1	25.000	60.000	29	70	
GM X 3	50.000	130.000	58	151	
GM X 4	100.000	200.000	116	232	

ТЕПЛОВОЙ РАСХОД / РАЗМЕРЫ (мм) - FIRING RATES / OVERALL DIMENSIONS (mm)

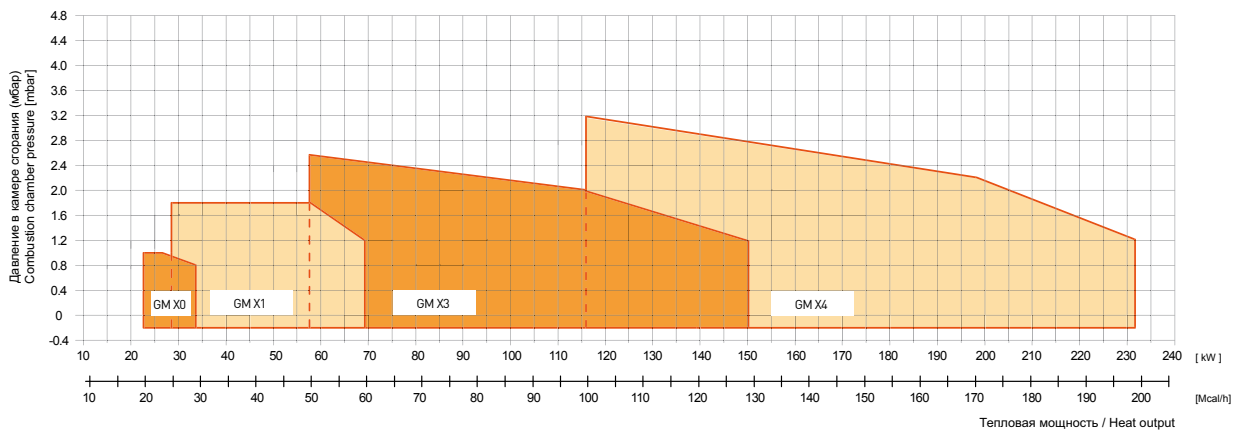
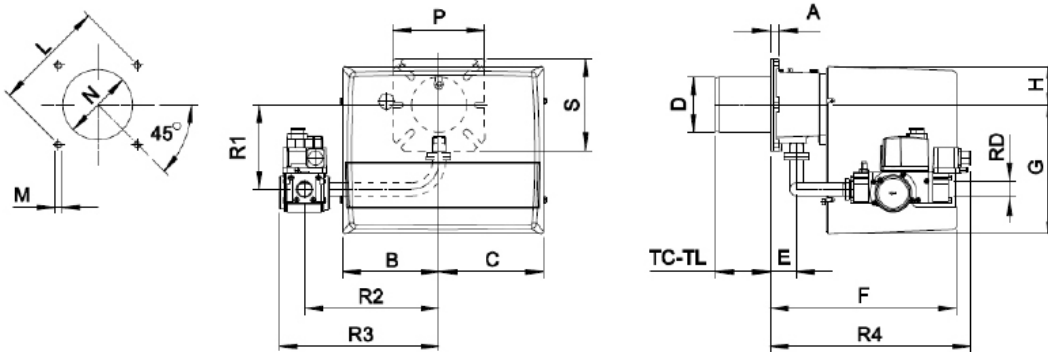

МОДЕЛЬ MODEL	*советовал/Suggested																							
	A	B	C	D	E	F	G	H	L min	L*	L max	M	N min	N*	N max	P	S	TC	TL	R1	R2	R3	R4	RD
GM X 0 - D1/2" - S	15	162	175	90	43	305	210	65	130	150	170	M8	100	110	130	150	150	90	150	132	200	254	240	1/2"
GM X 1 - D1/2" - S	15	162	175	90	43	305	210	65	130	150	170	M8	100	110	130	150	150	90	150	132	200	254	240	1/2"
GM X 1 - D3/4" - S	15	162	175	90	43	305	210	65	130	150	170	M8	100	110	130	150	150	90	150	138	220	262	328	3/4"
GM X 3 - D1" - S	16	185	195	108	54	340	248	70	150	170	170	M8	120	130	140	190	150	130	250	168	280	337	361	1"
GM X 4 - D1" - S	20	185	195	125	78	368	248	70	170	205	226	M10	130	140	160	200	200	160	280	173	280	337	385	1"





СЕРИЯ К

ДВУХСТУПЕНЧАТЫЕ ПРОГРЕССИВНЫЕ И МОДУЛИРУЮЩИЕ ОТ 116 ДО 1508 кВт
2 stages progressive and modulating from 116 up to 1508 kW

газ/дизельное топливо - Gas/Light Oil



ДВУХСТУПЕНЧАТЫЕ 2 STAGES	ПРОГРЕССИВНЫЕ И МОДУЛИРУЮЩИЕ PROGRESSIVE & MODULATING	kcal/h		kW		⚡
		min	max	min	max	
K 3/2	-	100.000	200.000	116	232	1F
K 4/2	-	200.000	450.000	232	523	3F
K 5/2	-	350.000	650.000	407	754	
K 6/2	K 6/M	500.000	1.000.000	581	1163	
K 7/2	K 7/M	700.000	1.300.000	812	1508	

ТЕПЛОВОЙ РАСХОД / РАЗМЕРЫ (мм) - FIRING RATES / OVERALL DIMENSIONS (mm)

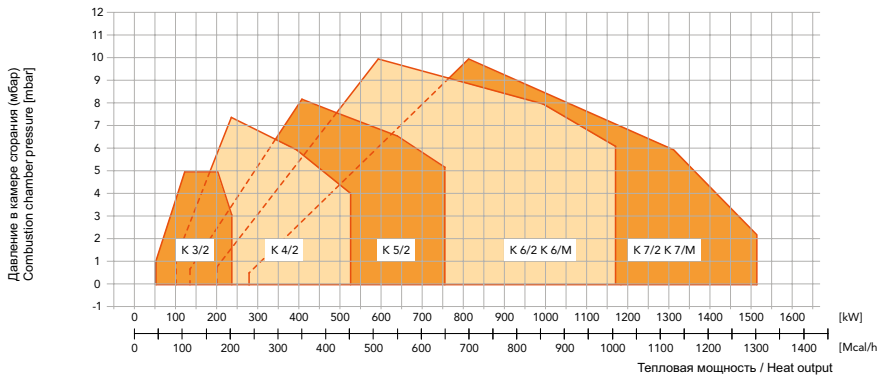
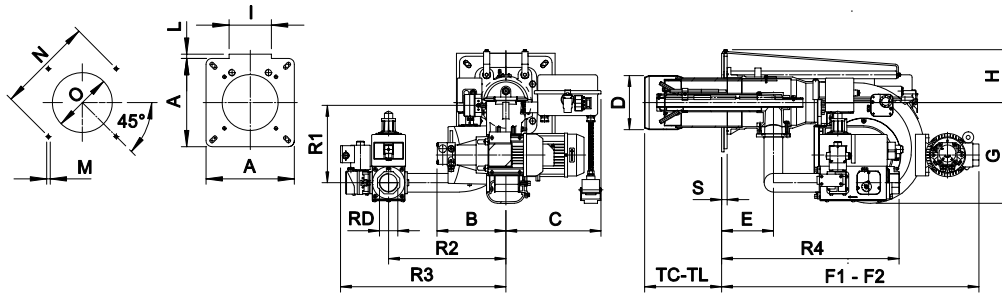

*советовал/Suggested

МОДЕЛЬ MODEL	A	B	C	D	E	F1	F2	G	H	I	L	M	N min	N max	O min*	O max	TC	TL	S	R1	R2	R3	R4	RD
K 3/2 - D1" - FS32	200	188	358	138	98	493	-	327	110	0	0	M10	205	226	150	180	250	350	18	171	280	411	354	1"
K 4/2 - D1" 1/2 - FS40	200	188	358	150	98	493	-	327	110	0	0	M10	205	226	160	180	250	350	18	203	280	432	456	1" 1/2
K 5/2 - D1" 1/2 - FS40	300	236	365	175	168	840	1280	327	171	144	10	M12	310	368	185	250	250	315	18	260	380	536	576	1" 1/2
K 5/2 - D2" - FS50	300	236	365	175	168	840	1280	327	171	144	10	M12	310	368	185	250	250	315	18	260	380	536	576	2"
K 6/2 - D2" - FS50	320	238	393	210	193	980	1560	438	213	183	40	M14	340	368	220	250	280	400	23	283	380	552	615	2"
K 6/2 - DN65 - FS65	320	238	393	210	193	980	1560	438	213	183	40	M14	340	368	220	250	280	400	23	228	340	495	585	DN65
K 6/2 - DN80 - FS80	320	238	393	210	193	980	1560	438	213	183	40	M14	340	368	220	250	280	400	23	228	420	590	605	DN80
K 7/2 - D2" - FS50	320	238	393	210	193	980	1560	438	213	183	40	M14	340	368	220	250	280	400	23	283	380	552	615	2"
K 7/2 - DN65 - FS65	320	238	393	210	193	980	1560	438	213	183	40	M14	340	368	220	250	280	400	23	228	340	495	585	DN65
K 7/2 - DN80 - FS80	320	238	393	210	193	980	1560	438	213	183	40	M14	340	368	220	250	280	400	23	228	420	590	605	DN80
K 6/M - D2" - FS50	320	380	393	210	193	1037	1617	438	267	183	40	M14	340	368	220	250	280	400	23	228	510	673	552	2"
K 6/M - DN65 - FS65	320	380	393	210	193	1037	1617	438	267	183	40	M14	340	368	220	250	280	400	23	228	510	665	586	DN65
K 6/M - DN80 - FS80	320	380	393	210	193	1037	1617	438	267	183	40	M14	340	368	220	250	280	400	23	228	550	720	626	DN80
K 7/M - D2" - FS50	320	380	393	210	193	1037	1617	438	267	183	40	M14	340	368	220	250	280	400	23	228	510	673	552	2"
K 7/M - DN65 - FS65	320	380	393	210	193	1037	1617	438	267	183	40	M14	340	368	220	250	280	400	23	228	510	665	586	DN65
K 7/M - DN80 - FS80	320	380	393	210	193	1037	1617	438	267	183	40	M14	340	368	220	250	280	400	23	228	550	720	626	DN80

СЕРИЯ К

ПРОГРЕССИВНЫЕ И МОДУЛИРУЮЩИЕ ОТ 1044 ДО 2900 кВт
Progressive and modulating from 1044 up to 2900 kW



газ/дизельное топливо - Gas/Light Oil



ПРОГРЕССИВНЫЕ И МОДУЛИРУЮЩИЕ PROGRESSIVE & MODULATING	kcal/h		kW		3F
	min	max	min	max	
K 190/M*	900.000	2.019.000	1044	2390	
K 250/M*	1.000.000	2.500.000	1160	2900	

* Имеются также в версии Low Nox
* Available also in Low NOx version

ТЕПЛОВОЙ РАСХОД / РАЗМЕРЫ (мм) - FIRING RATES / OVERALL DIMENSIONS (mm)

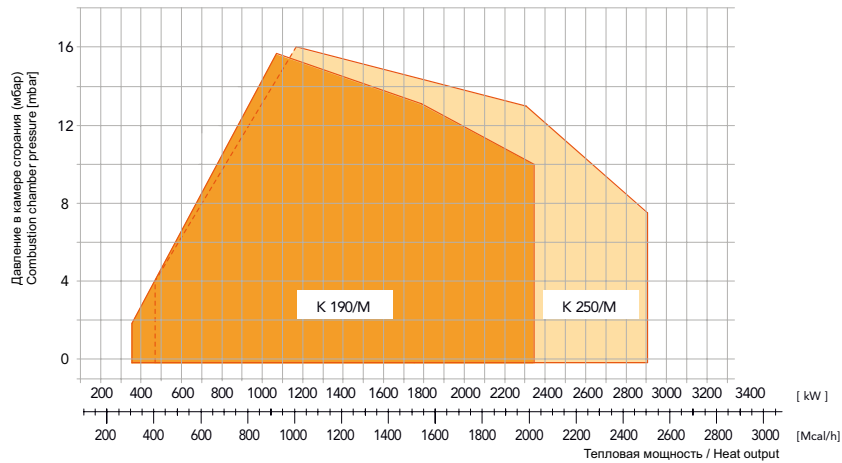
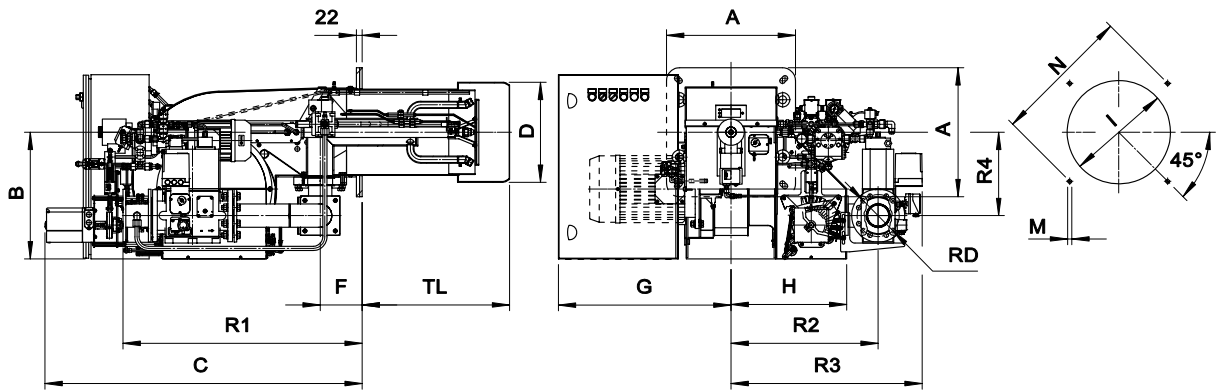

МОДЕЛЬ MODEL	*советовал/Suggested																			
	A	B	C	D	E	F	G	H	I min	I*	I max	M	N min	N*	N max	R1	R2	R3	R4	RD
K 190/M - D2" - FS50	360	453	1100	145	481	265	545	363	280	280	320	M14	396	424	438	604	509	672	254	2"
K 190/M - DN65 - FS65	360	453	1100	145	481	265	545	363	280	280	320	M14	396	424	438	788	480	634	254	DN65
K 190/M - DN80 - FS80	360	453	1100	145	481	265	545	363	280	280	320	M14	396	424	438	808	480	647	254	DN80
K 190/M - DN100 - FS100	360	453	1100	145	481	265	545	363	280	280	320	M14	396	424	438	848	480	654	254	DN100
K 250/M - D2" - FS50	360	453	1100	145	481	265	545	363	280	280	320	M14	396	424	438	604	509	672	254	2"
K 250/M - DN65 - FS65	360	453	1100	145	481	265	545	363	280	280	320	M14	396	424	438	788	480	634	254	DN65
K 250/M - DN80 - FS80	360	453	1100	145	481	265	545	363	280	280	320	M14	396	424	438	808	480	647	254	DN80
K 250/M - DN100 - FS100	360	453	1100	145	481	265	545	363	280	280	320	M14	396	424	438	848	480	654	254	DN100



СЕРИЯ К

ДВУХСТУПЕНЧАТЫЕ ПРОГРЕССИВНЫЕ И МОДУЛИРУЮЩИЕ ОТ 1390 ДО 6395 кВт
2 stages progressive and modulating from 1390 up to 6395 kW

газ/дизельное топливо - Gas/Light Oil



ПРОГРЕССИВНЫЕ И МОДУЛИРУЮЩИЕ PROGRESSIVE & MODULATING	kcal/h		kW		3F
	min	max	min	max	
К 350/М *	1.200.000	3.500.000	1390	4060	3F
К 450/М *	1.600.000	4.500.000	1850	5220	
К 550/М *	2.000.000	5.500.000	2325	6395	

- * Имеются также в версии Low Nox
- * Available also in Low NOx version
- ** Поставляются также версии с ИНВЕРТОРОМ и ЭЛЕКТРОННЫМ КУЛАЧКОМ
- ** Available also versions with INVERTER and ELECTRONIC BURNER CONTROL

ТЕПЛОВЫЙ РАСХОД / РАЗМЕРЫ (мм) - FIRING RATES / OVERALL DIMENSIONS (mm)

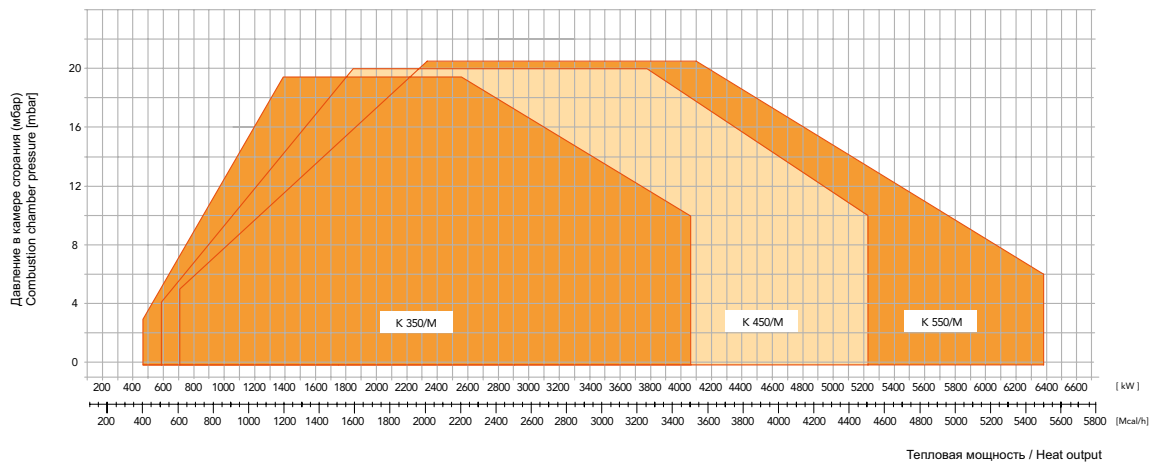
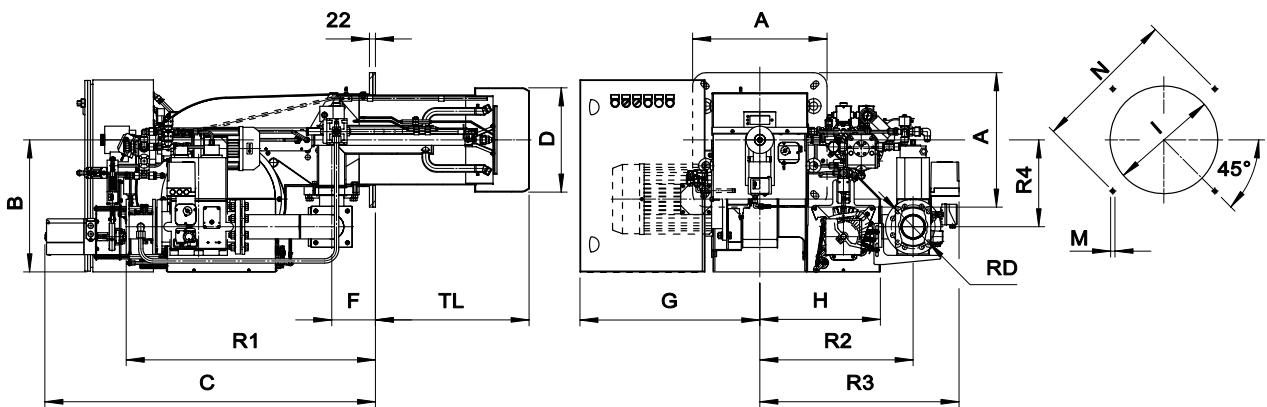

МОДЕЛЬ MODEL	A	B	C	D	E	F	G	H	I min	I*	I max	M	min	N*	max	R1	R2	R3	R4	RD
К 350/М - D2" - FS50	490	481	1206	160	535	334	600	440	350	350	450	M14	552	552	580	670	535	664	317	D2"
К 350/М - DN65 - FS65	490	481	1206	160	535	334	600	440	350	350	450	M14	552	552	580	880	560	715	317	DN65
К 350/М - DN80 - FS80	490	481	1206	160	535	334	600	440	350	350	450	M14	552	552	580	900	560	730	317	DN80
К 350/М - DN100 - FS100	490	481	1206	160	535	334	600	440	350	350	450	M14	552	552	580	940	590	765	317	DN100
К 450/М - D2" - FS50	490	481	1206	160	560	380	600	440	390	390	450	M14	552	552	580	670	535	664	317	D 2"
К 450/М - DN65 - FS65	490	481	1206	160	560	380	600	440	390	390	450	M14	552	552	580	880	560	715	317	DN65
К 450/М - DN80 - FS80	490	481	1206	160	560	380	600	440	390	390	450	M14	552	552	580	900	560	730	317	DN80
К 450/М - DN100 - FS100	490	481	1206	160	560	380	600	440	390	390	450	M14	552	552	580	940	590	765	317	DN100
К 550/М - D2" - FS50	490	481	1206	160	560	380	661	440	390	390	450	M14	552	552	580	670	535	664	317	D2"
К 550/М - DN65 - FS65	490	481	1206	160	560	380	661	440	390	390	450	M14	552	552	580	880	560	715	317	DN65
К 550/М - DN80 - FS80	490	481	1206	160	560	380	661	440	390	390	450	M14	552	552	580	900	560	730	317	DN80
К 550/М - DN100 - FS100	490	481	1206	160	560	380	661	440	390	390	450	M14	552	552	580	940	590	765	317	DN100

*советовал/Suggested



СЕРИЯ К

ПРОГРЕССИВНЫЕ И МОДУЛИРУЮЩИЕ ОТ 3488 ДО 17445 кВт
Progressive and modulating from 3488 up to 17445 kW



газ/дизельное топливо - Gas/Light Oil



ПРОГРЕССИВНЫЕ И МОДУЛИРУЮЩИЕ PROGRESSIVE & MODULATING	kcal/h 		kW		
	min	max	min	max	
К 650/М *	3.000.000	6.500.000	3488	7558	3F
К 750/М *	3.400.000	7.500.000	4000	8721	
К 1000/М *	3.400.000	10.000.000	4000	11628	
К 1150/М *	3.600.000	11.500.000	4186	13372	
К 1300/М *	3.600.000	13.000.000	4186	15116	
К 1500/М *	5.000.000	15.000.000	5815	17445	

* Поставляются также версии с ИНВЕРТОРОМ и ЭЛЕКТРОННЫМ КУЛАЧКОМ
* Available also versions with INVERTER and ELECTRONIC BURNER CONTROL

ТЕПЛОЙ РАСХОД / РАЗМЕРЫ (мм) - FIRING RATES / OVERALL DIMENSIONS (mm)

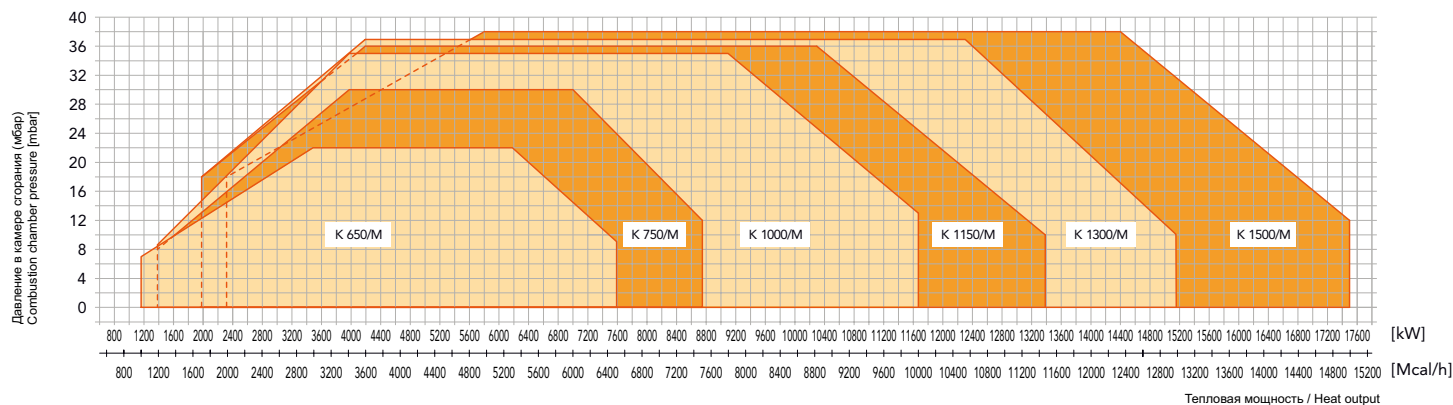

Please contact our Technical & Sales Offices for detailed technical data.



СЕРИЯ KN

ПРОГРЕССИВНЫЕ И МОДУЛИРУЮЩИЕ ОТ 1044 ДО 6380 кВт
Progressive and modulating from 1044 up to 6380 kW

газ/тяжелое топливо - Gas/Heavy Oil



ПРОГРЕССИВНЫЕ И МОДУЛИРУЮЩИЕ PROGRESSIVE & MODULATING	kcal/h		kW		3F
	min	max	min	max	
KN 190/M *	900.000	2.019.000	1044	2341	
KN 250/M *	1.000.000	2.500.000	1160	2900	
KN 350/M *	1.200.000	3.500.000	1390	4060	
KN 450/M *	1.600.000	4.500.000	1850	5220	
KN 550/M *	2.000.000	5.500.000	2325	6380	

* Поставляются также версии с ИНВЕРТОРОМ и ЭЛЕКТРОННЫМ КУЛАЧКОМ
* Available also versions with INVERTER and ELECTRONIC BURNER CONTROL

ТЕПЛОВЫЙ РАСХОД / РАЗМЕРЫ (мм) - FIRING RATES / OVERALL DIMENSIONS (mm)

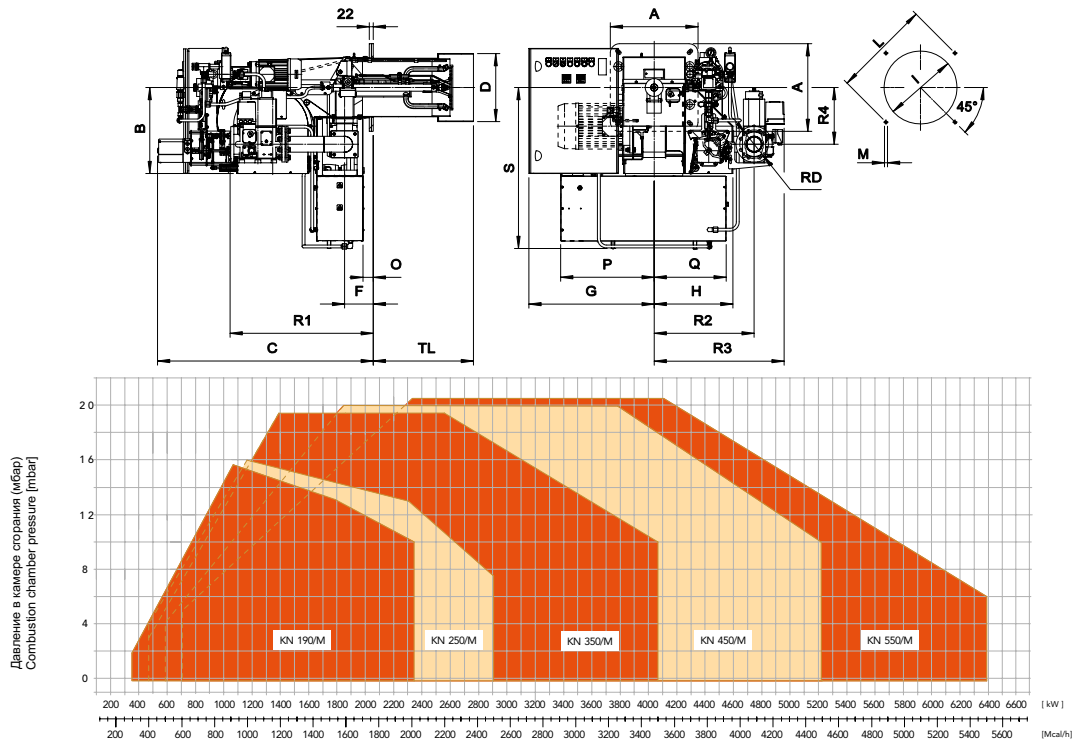

МОДЕЛЬ MODEL	Тепловая мощность / Heat output																				* советовав/Suggested			
	A	B	C	D	F	G	H	I _{min}	I [*]	I _{max}	L _{min}	L [*]	L _{max}	M14	O	P	Q	S	TL	R1		R2	R3	R4
KN 190/M - D2" - FS50	360	453	1100	265	145	545	363	280	280	320	396	424	438	M14	93	403	403	790	480	504	509	672	260	2"
KN 190/M - DN65 - FS65	360	453	1100	265	145	545	363	280	280	320	396	424	438	M14	93	403	403	790	480	688	480	634	260	DN65
KN 190/M - DN80 - FS80	360	453	1100	265	145	545	363	280	280	320	396	424	438	M14	93	403	403	790	480	708	480	648	260	DN80
KN 190/M - DN100 - FS100	360	453	1100	265	145	545	363	280	280	320	396	424	438	M14	93	403	403	790	480	748	480	655	260	DN100
KN 250/M - D2" - FS50	360	453	1100	265	145	545	363	280	280	320	396	424	438	M14	93	403	403	790	480	504	509	672	260	2"
KN 250/M - DN65 - FS65	360	453	1100	265	145	545	363	280	280	320	396	424	438	M14	93	403	403	790	480	688	480	634	260	DN65
KN 250/M - DN80 - FS80	360	453	1100	265	145	545	363	280	280	320	396	424	438	M14	93	403	403	790	480	708	480	648	260	DN80
KN 250/M - DN100 - FS100	360	453	1100	265	145	545	363	280	280	320	396	424	438	M14	93	403	403	790	480	748	480	655	260	DN100
KN 350/M - D2" - FS50	490	481	1206	334	160	600	440	350	350	450	552	552	580	M14	57	523	405	762	535	570	535	648	317	2"
KN 350/M - DN65 - FS65	490	481	1206	334	160	600	440	350	350	450	552	552	580	M14	57	523	405	762	535	780	560	713	317	DN65
KN 350/M - DN80 - FS80	490	481	1206	334	160	600	440	350	350	450	552	552	580	M14	57	523	405	762	535	800	560	726	317	DN80
KN 350/M - DN100 - FS100	490	481	1206	334	160	600	440	350	350	450	552	552	580	M14	57	523	405	762	535	840	560	764	317	DN100
KN 450/M - D2" - FS50	490	481	1206	380	160	700	440	390	390	450	552	552	580	M14	57	523	405	905	560	570	535	648	317	2"
KN 450/M - DN65 - FS65	490	481	1206	380	160	700	440	390	390	450	552	552	580	M14	57	523	405	905	560	780	560	713	317	DN65
KN 450/M - DN80 - FS80	490	481	1206	380	160	700	440	390	390	450	552	552	580	M14	57	523	405	905	560	800	560	726	317	DN80
KN 450/M - DN100 - FS100	490	481	1206	380	160	700	440	390	390	450	552	552	580	M14	57	523	405	905	560	840	560	764	317	DN100
KN 550/M - D2" - FS50	490	481	1206	380	160	700	440	390	410	450	552	552	580	M14	57	523	405	905	560	570	535	648	317	2"
KN 550/M - DN65 - FS65	490	481	1206	380	160	700	440	390	410	450	552	552	580	M14	57	523	405	905	560	780	560	713	317	DN65
KN 550/M - DN80 - FS80	490	481	1206	380	160	700	440	390	410	450	552	552	580	M14	57	523	405	905	560	800	560	726	317	DN80
KN 550/M - DN100 - FS100	490	481	1206	380	160	700	440	390	410	450	552	552	580	M14	57	523	405	905	560	840	560	764	317	DN100

СЕРИЯ KN

ПРОГРЕССИВНЫЕ И МОДУЛИРУЮЩИЕ ОТ 3488 ДО 17445 кВт
Progressive and modulating from 3488 up to 17445 kW



газ/тяжелое топливо - Gas/Heavy Oil



ПРОГРЕССИВНЫЕ И МОДУЛИРУЮЩИЕ PROGRESSIVE & MODULATING	kcal/h		kW		3F
	min	max	min	max	
KN 650/M *	3.000.000	6.500.000	3488	7558	3F
KN 750/M *	3.400.000	7.500.000	4000	8721	
KN 1000/M *	3.400.000	10.000.000	4000	11628	
KN 1150/M *	3.600.000	11.500.000	4186	13372	
KN 1300/M *	3.600.000	13.000.000	4186	15116	
KN 1500/M *	5.000.000	15.000.000	5815	17445	

* Поставляются также версии с ИНВЕРТОРОМ и ЭЛЕКТРОННЫМ КУЛАЧКОМ
* Available also versions with INVERTER and ELECTRONIC BURNER CONTROL

ТЕПЛОВЫЙ РАСХОД / РАЗМЕРЫ (мм) - FIRING RATES / OVERALL DIMENSIONS (mm)

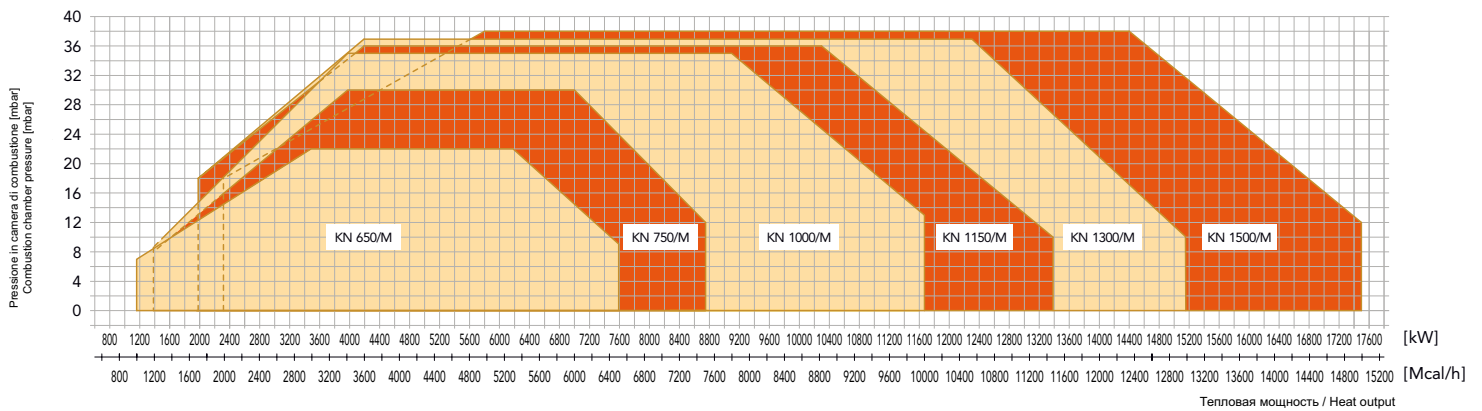

Please contact our Technical & Sales Offices for detailed technical data.

Industrial burners are designed for residential plants and industrial processes that need high heating powers. The actual range is characterized by duo block burners with separated ventilator to be installed based on specific and real technical needs (ventilator not included).

When a significant amount of heating is needed, a single ventilator is able to work for more industrial burners, simplifying the entire heating plant. It's possible to use pre-heated combustion air, exploiting heat recovery from flue gases.

Available for the use of different types of fuel (light oil, heavy oil, natural gas, LPG), the industrial burners can be customized based on final plant characteristics and Your real needs. Thanks to last technical innovations, the industrial burners are easy to be installed.

Please contact our Technical & Sales Offices for the study of Your specific needs.

ПРОМЫШЛЕННЫЕ ГОРЕЛКИ INDUSTRIAL BURNERS

5

ГОРЕЛКИ ДЛЯ ДИЗЕЛЬНОГО ТОПЛИВА / LIGHT OIL BURNERS



МОДЕЛЬ MODEL	kg/h		kW		⚡
	min	max	min	max	
HI-FGP 190/M TL	60	206	700	2390	3F
HI-FGP 250/M TL	80	250	930	2900	
HI-FGP 350/M TL	120	350	1392	4060	
HI-FGP 450/M TL	160	450	1856	5220	
HI-FGP 550/M TL	200	550	2320	6380	
HI-FGP 650/M TL	300	650	3488	7558	
HI-FGP 750/M TL	340	750	4000	8721	
HI-FGP 1000/M TL	340	1000	4000	11628	
HI-FGP 1150/M TL	353	1128	4186	13372	
HI-FGP 1300/M TL	353	1274	4186	15116	
HI-FGP 1500/M TL	500	1500	5815	17445	



ГОРЕЛКИ ДЛЯ ТЯЖЕЛОГО ТОПЛИВА / HEAVY OIL BURNERS

МОДЕЛЬ MODEL	kg/h		kW		⚡
	min	max	min	max	
HI-FNDP 190/M TL	80	206	928	2341	3F
HI-FNDP 250/M TL	100	250	1160	2842	
HI-FNDP 350/M TL	120	350	1364	3979	
HI-FNDP 450/M TL	160	450	1819	5116	
HI-FNDP 550/M TL	200	550	2274	6252	
HI-FNDP 650/M TL	300	650	3488	7558	
HI-FNDP 750/M TL	340	750	4000	8721	
HI-FNDP 1000/M TL	340	1000	4000	11628	
HI-FNDP 1150/M TL	367	1173	4186	13372	
HI-FNDP 1300/M TL	367	1326	4186	15116	
HI-FNDP 1500/M TL	500	1500	5815	17445	



ГОРЕЛКИ ДЛЯ ГАЗА / GAS BURNERS

МОДЕЛЬ MODEL	kcal/h		kW		⚡
	min	max	min	max	
HI-GAS P190/M CE TL	900.000	1.900.000	1044	2204	3F
HI-GAS P250/M CE TL	1.000.000	2.500.000	1160	2900	
HI-GAS P350/M CE TL	1.200.000	3.500.000	1390	4060	
HI-GAS P450/M CE TL	1.600.000	4.500.000	1850	5220	
HI-GAS P550/M CE TL	2.000.000	5.500.000	2325	6380	
HI-GAS P650/M CE TL	3.000.000	6.500.000	3488	7558	
HI-GAS P750/M CE TL	3.400.000	7.500.000	4000	8721	
HI-GAS P1000/M CE TL	3.400.000	10.000.000	4000	11628	
HI-GAS P1150/M CE TL	3.600.000	11.500.000	4186	13372	
HI-GAS P1300/M CE TL	3.600.000	13.000.000	4186	15116	
HI-GAS P1500/M CE TL	5.000.000	15.000.000	5815	17445	



ГОРЕЛКИ КОМБИ / DUAL FUEL BURNERS

ГАЗ/ДИЗЕЛЬНОГО ТОПЛИВА GAS/LIGHT OIL	kcal/h		kW		⚡
	min	max	min	max	
HI-K 190/M TL	900.000	2.019.000	1044	2341	3F
HI-K 250/M TL	900.000	2.400.000	1044	2790	
HI-K 350/M TL	1.200.000	3.500.000	1392	4060	
HI-K 450/M TL	1.600.000	4.500.000	1856	5220	
HI-K 550/M TL	2.000.000	5.500.000	2320	6380	
HI-K 650/M TL	3.000.000	6.500.000	3488	7558	
HI-K 750/M TL	3.400.000	7.500.000	4000	8721	
HI-K 1000/M TL	3.400.000	10.000.000	4000	11628	
HI-K 1150/M TL	3.600.000	11.500.000	4186	13372	
HI-K 1300/M TL	3.600.000	13.000.000	4186	15116	
HI-K 1500/M TL	5.000.000	15.000.000	5815	17445	

ГАЗ/ТЯЖЕЛОЕ ТОПЛИВО GAS/HEAVY OIL	kcal/h		kW		⚡
	min	max	min	max	
HI-KN 190/M TL	900.000	2.019.000	1044	2341	3F
HI-KN 250/M TL	900.000	2.400.000	1044	2790	
HI-KN 350/M TL	1.200.000	3.500.000	1392	4060	
HI-KN 450/M TL	1.600.000	4.500.000	1856	5220	
HI-KN 550/M TL	2.000.000	5.500.000	2320	6380	
HI-KN 650/M TL	3.000.000	6.500.000	3488	7558	
HI-KN 750/M TL	3.400.000	7.500.000	4000	8721	
HI-KN 1000/M TL	3.400.000	10.000.000	4000	11628	
HI-KN 1150/M TL	3.600.000	11.500.000	4186	13372	
HI-KN 1300/M TL	3.600.000	13.000.000	4186	15116	
HI-KN 1500/M TL	5.000.000	15.000.000	5815	17445	

Приведенные изображения и данные могут быть неточными. Поскольку компания F.B.R. Bruciatori S.r.l. постоянно улучшает свою продукцию, она оставляет за собой право на внесение без предварительного уведомления всех изменений, которые будут признаны необходимыми для развития своей продукции.
The illustrations and data here shown are indicative. Being constantly involved in the continuous improvement of the whole production range, F.B.R. Bruciatori S.r.l. reserves the right to bring, without any obligation of warning, any changes that would be appropriate to the continuing development of their products.





MADE IN ITALY

F.B.R. BRUCIATORI S.r.l.

37050 ANGIARI (Verona) _ Italy _ Via V. Veneto, 152

Tel. +39 0442 97000 _ Fax +39 0442 97299

www.fbr.it

e-mail fbr@fbr.it